



ЕЛЕКТРОСВЯТ

АДРЕС: ГР.ЕЛИН ПЕЛИН, БУЛЕВАРД ВИТОША 48
ТЕЛ: 0720 98116, Е-МЕЙЛ: SKLAD@ELECTROSVIAT.COM

B2B: B2B.ELECTROSVIAT.COM WEBSITE: WWW.ELECTROSVIAT.COM

**PRODUCT
PRESENTATION**

KETER



KETER[®]

We have developed three distinctly segmented brands with product lines that can be clearly identified by retailers and end users. Starting from **ROC** for hard-core professionals that meets and surpasses the expectations of a trade audience. Secondly, **PRO SERIES** a brand that is identifiable with the committed individual and finally **KETER** an entry-level brand designed for everyday users. Each range has been carefully considered to ensure each meets and exceeds the demands of the individuals they target.



KETER®

ROC

TRADE FOCUSED PROFESSIONAL

Professionals demand tough and rugged tool storage that can withstand harsh elements on a daily basis, the ROC brand encapsulates this with its heavy-duty, performance focused range of tools and accessories. Designed for the toughest tasks and rigorously tested for optimum endurance under severe conditions, the range includes stackable storage boxes and workbenches offering functional and versatile solutions that are designed to stand up to whatever a job throws at them.



KETER

PRO

SERIES

PRO SERIES OVERVIEW

The PRO Series is made for the dedicated enthusiast. This strong and durable range will keep power tools, equipment and accessories expertly organised and robustly stored, earning the trust of everyone from the dedicated home enthusiast right through to tradesmen and pros. The range is made up of strong, spacious and durable connecting toolboxes and multifunctional workbenches offering users superb organisation and safe storage that is built to last.



KETER®

KETER TOOLS

STACK N' ROLL



KETER®

EVERYDAY. EVERYWHERE.

The Keter Everyday range offers great value and reliability, these products are for everyone from the hobbyists to the artists right through to those that need practical and reliable everyday storage for tools and equipment around the home, featuring smart and functional design the Keter Everyday range includes toolboxes, caddies and stackable bins each has been tailored to fit within the home with ease and designed to make life easier.



KETER[®]
RDC



GEAR SERIES

DESCRIPTION



Introducing the GEAR tool storage system – a mobile, stackable tool storage system for separate or combined use. The Mobile Gear Cart is a totally portable, heavy-duty cart with telescopic handle and wheels, so you can transport your equipment with ease. The open “catch all” Crate is great for carrying bulky tools and accessories. Stack it on top of the Gear Cart for extra storage and extra mobility. The top Gear Organizer is designed for small parts and accessories, and includes removable bins for fast access on the job. All toolboxes feature water-resistant rim, metal lid stopper for tough lid performance, and metal side handles. Want a mobile storage solution? Connect the three boxes with the high-performance stacking lock and get moving with the professional tool storage system!



GEAR SERIES

DESCRIPTION

KETER

RDC

Customize your own storage system!



22" GEAR MOBILE CART

LOGISTIC DATA

KETER

RDC

PRODUCT

Dimensions 56,4x46,5x48 cm

Net weight 8 kg

PACK UNIT INFORMATION

Dimensions 57,4x47,5x82 cm

Pack size 2 

PALLET INFORMATION

Dimensions 115x100x222,3 cm

Pieces/pallet 20

Cartons/layer 4

Layers/pallet 2 + 2 pack

CODIFICATION

EAN ART. NR. SAP CODE

7290106927094 17200383 236889



22" GEAR MOBILE CART

BENEFITS

KETER

RDC



Solid metal telescopic handle



Rubber coated wheels ensure easy transportation



Boxes can be connected using the high-performance stacking locks



Integrated tool bar

22" GEAR CRATE

LOGISTIC DATA

KETER

RDC

PRODUCT

Dimensions 56,4x32x25 cm
Net weight 2,1 kg

PACK UNIT INFORMATION

Dimensions 57x33x122 cm
Pack size 5 

PALLET INFORMATION

Dimensions 120x80x192 cm
Pieces/pallet 30
Cartons/layer 4
Layers/pallet 1 + 2 pack

CODIFICATION

EAN	ART. NR.	SAP CODE
7290106930469	17202245	238276



22" GEAR CRATE

BENEFITS

KETER

ROG



Open top allows for easy access to tools or accessories

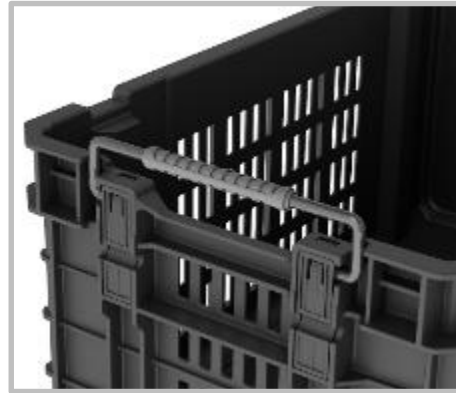

Metal side handles provide a comfortable and efficient method of transportation

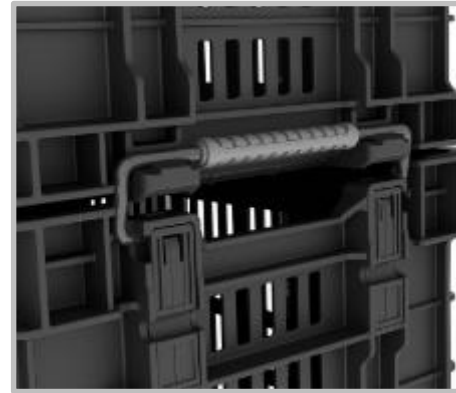

Stackable design featuring metal stacking locks



Compatible with GEAR series

22" GEAR ORGANIZER

LOGISTIC DATA



PRODUCT

Dimensions 56x34,5x12,8 cm
Net weight 3 kg

PACK UNIT INFORMATION

Dimensions 58x51,5x36 cm
Pack size 4 

PALLET INFORMATION

Dimensions 120x80x190,5 cm
Pieces/pallet 40
Cartons/layer 2
Layers/pallet 5

CODIFICATION

EAN	ART. NR.	SAP CODE
7290112630964	17206659	240457



22" GEAR ORGANIZER

BENEFITS

KETER

ROD



Sturdy polycarbonate lid



Integral water seal



8 small and 2 wide (with additional dividers) removable bins



Stackable with side handles

JOB BOX

DESCRIPTION

The JOB BOX is perfect for professionals who require a mobile cart to help them move from one job to another with ease. Practical and convenient, this spacious cart provides an all-in-one solution for storing and transporting larger tools, medium sized accessories and small parts. The cantilever mechanism opens up to give access to any area of the cart. Easy to customize, the cart can be transformed from a three to an eight compartment unit by adding or removing the dividers. A central locking system keeps the contents secure. Mobile and practical, this cart comes with 7" rubber wheels and a large retractable metal handle with a soft grip.



PRODUCT

Dimensions 64,6x37,3x41 cm
Net weight 4,8 kg

PACK UNIT INFORMATION

Dimensions 65,5x38,3x83,5 cm
Pack size 2 

PALLET INFORMATION

Dimensions 120x80x219 cm
Pieces/pallet 14
Cartons/layer 3
Layers/pallet 2 + 1 pack

CODIFICATION

EAN	ART. NR.	SAP CODE
7290106934238	17203037	238270



JOB BOX

BENEFITS



Heavy duty cantilever system for convenient spread of content



Up to 8 compartments with the included dividers



Water and dust seal for tools protection



Spacious container for big tools



7" all terrain rubber wheels



Heavy duty metal handle with soft grip



Durable metal latches



Lockable

10 COMPARTMENT PRO ORGANIZER

DESCRIPTION



Make sure you have everything you need to complete professional or personal projects by using this convenient and spacious organizer. Designed with 10 compartments, including 8 small and 2 big bins, the organizer will keep your small parts in perfect order. The extra-tough clear lid also has a no-travel bin seal, so your small components will stay in their bins when the lid is closed.



10 COMPARTMENT PRO ORGANIZER

LOGISTIC DATA

KETER

RDC

PRODUCT

Dimensions 46,2x36x11 cm

Net weight 2,4 kg

PACK UNIT INFORMATION

Dimensions 49x37,7x35,7 cm

Pack size 3 

PALLET INFORMATION

Dimensions 120x80x208,5 cm

Pieces/pallet 72

Cartons/layer 6

Layers/pallet 4

CODIFICATION

EAN ART. NR. SAP CODE

7290106930063 17201702 238371



10 COMPARTMENT PRO ORGANIZER

BENEFITS

KETER

ROD



Transparent lid



8 small and 2 wide bins



No-travel bin seals keeps contents from shifting between bins



Weather seal protects contents from water damage



Possibility to stack organizers



Full access while stacked



Durable latches



Carrying handle

LUMBERJACK SAWHORSE

DESCRIPTION

KETER

RDC

Taking the sawhorse concept to new heights, the innovative Lumberjack™ will suit professionals and DIYers who need a multifunctional product to meet their ever-changing requirements. A unique ratcheting opening and closing system offers a fast and easy height adjustment setup. The integrated wood piece is a standard 2"x4" size and can be used in multiple ways to create a unique and personalized work area. You can create your own jigs to suit various projects, use it with a wider wood piece attached on top for a larger work space, or with a longer piece to extend your work surface. The piece can be easily replaced when needed as it has standard measurements. This practical sawhorse has heavy-duty metal legs that can be adjusted individually, allowing for uneven surfaces and raising the sawhorse from 31" to 39". With a capacity of 3000 lbs/1360 kg per pair the compact Lumberjack™ will handle various types of jobs perfectly. A bottom tool tray with a capacity of 50 lbs/23 kg adds more functionality and more stability to the design.



LUMBERJACK SAWHORSE

LOGISTIC DATA

KETER

RDC

PRODUCT

Dimensions 71x6,9x82 cm

Net weight 7,2 kg

PACK UNIT INFORMATION

Dimensions 72,5x32x84 cm

Pack size 4 

PALLET INFORMATION

Dimensions 100x76x178,5 cm

Pieces/pallet 24

Cartons/layer 3

Layers/pallet 2

CODIFICATION

EAN ART. NR. SAP CODE

7290106934245 17203039 238271



LUMBERJACK SAWHORSE

BENEFITS

KETER

RDC



Heavy-duty lumberjack



2" x 4" multifunctional wood piece included



Thanks to individually adjustable metal legs lumberjack can be used on uneven surfaces

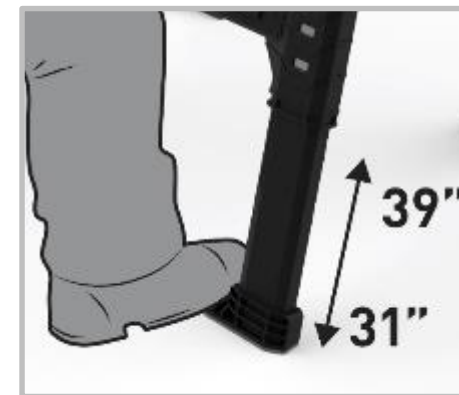

Height ranges from 31" to 39"



Bottom tray with weight capacity of 23 kg



Step'n Lift height adjustable ratcheting mechanism



Folded to save space



Max weight 1360 kg per pair

LUMBERJACK SAWHORSE

BENEFITS



Create your own jigs to suit various projects



KETER[®]
PRO
S E R I E S



CONNECT SERIES

DESCRIPTION



A comprehensive organizing and transportation solution, this mobile Connect Rolling System makes your job easier, whether you're a professional or a DIYer. Designed with convenience in mind, the system is completely mobile and modular, so you can take it anywhere with you and configure it to suit your requirements. It features durable stacking locks, a cart for bulky tools, a tool box, and an organizer for small parts.



CONNECT ROLLING SYSTEM

LOGISTIC DATA



PRODUCT

Dimensions 56,5x37,3x70 cm
Net weight 9,15 kg

PACK UNIT INFORMATION

Dimensions 57,5x38,3x71,5 cm
Pack size 1 

PALLET INFORMATION

Dimensions 120x80x196 cm
Pieces/pallet 10
Cartons/layer 4
Layers/pallet 2 + 2 pack

CODIFICATION

EAN	ART. NR.	SAP CODE
7290106934221	17203038	238273



CONNECT ROLLING SYSTEM

BENEFITS



Heavy-duty construction guaranteeing years of use



Organizer for accessories with removable 8 small and 2 wide bins



Spacious tool box for bigger tools with additional tray



Heavy-duty mobile cart



Rubber coated wheels ensure easy transportation



Durable metal latches



Heavy duty metal stacking lock connectors



Stabilizer dual support legs

CONNECT ORGANIZER+CART

LOGISTIC DATA



PRODUCT

Dimensions 56,5x37,3x55 cm
Net weight 6,15 kg

PACK UNIT INFORMATION

Dimensions 57,5x38,3x57 cm
Pack size 1 

PALLET INFORMATION

Dimensions 120x80x187 cm
Pieces/pallet 12
Cartons/layer 4
Layers/pallet 3

CODIFICATION

EAN	ART. NR.	SAP CODE
7290112630407	17205661	239996



CONNECT CADDY

LOGISTIC DATA



PRODUCT

Dimensions 54,3x30,2x13,9 cm
Net weight 1,56 kg

PACK UNIT INFORMATION

Dimensions 57x31x52,3 cm
Pack size 4 

PALLET INFORMATION

Dimensions 120x80x169,5 cm
Pieces/pallet 64
Cartons/layer 2 / 2
Layers/pallet 5 / 3

CODIFICATION

EAN	ART. NR.	SAP CODE
7290106939769	17206124	237897



CONNECT CADDY

BENEFITS



Compatible with the Connect Rolling System



Easily connect to the Connect Series



Heavy Duty construction with multiple storage compartments, 3 dividers



Folding metal handle – stack and go

22" CONNECT CANTILEVER ORGANIZER

LOGISTIC DATA



PRODUCT

Dimensions 56,5x31,7x16,1 cm
Net weight 3,6 kg

PACK UNIT INFORMATION

Dimensions 57,5x32,7x63,5 cm
Pack size 4 

PALLET INFORMATION

Dimensions 120x80x204,5 cm
Pieces/pallet 48
Cartons/layer 4
Layers/pallet 3

CODIFICATION

EAN	ART. NR.	SAP CODE
7290106934108	17203103	238274



22" CONNECT CANTILEVER ORGANIZER

BENEFITS



Heavy-duty construction



Multiple sized removable bins allow for efficient tool and small parts organization



Extra tough clear lid



Metal latches keep the contents secure



Compatible with the CONNECT ROLLING SYSTEM



Cantilever system allows easy access to contents



Back legs provide optimum support and keep the organizer stable at all times



Wide metal handle with soft grip

22" CONNECT CANTILEVER TOOLBOX

LOGISTIC DATA



PRODUCT

Dimensions 56,5x31,7x25,1 cm
Net weight 3,6 kg

PACK UNIT INFORMATION

Dimensions 57,5x32,7x50,5 cm
Pack size 2 

PALLET INFORMATION

Dimensions 120x80x213 cm
Pieces/pallet 40
Cartons/layer 2/2
Layers/pallet 6/4

CODIFICATION

EAN	ART. NR.	SAP CODE
7290106934214	17203104	238275



22" CONNECT CANTILEVER TOOLBOX

BENEFITS



Heavy-duty construction



10 small and 2 wide bins



Extra tough clear lid



Metal latches keep the contents secure



Compatible with the CONNECT ROLLING SYSTEM



Cantilever system allows easy access to contents



Back legs provide optimum support and keep the organizer stable at all times



Horizontal carrying keeps tools and accessories in place

CONNECT TROLLEY

LOGISTIC DATA



PRODUCT

Dimensions 55,6x43,7x16,4 cm
Net weight 2,91 kg

PACK UNIT INFORMATION

Dimensions 57x45,5x60 cm
Pack size 4 

PALLET INFORMATION

Dimensions 120x80x196,5 cm
Pieces/pallet 32
Cartons/layer 2
Layers/pallet 4

CODIFICATION

EAN	ART. NR.	SAP CODE
7290106937437	17205514	240050



CONNECT TROLLEY

BENEFITS



Compatible with the Connect Trolley System



Designed to carry 18 l bucket

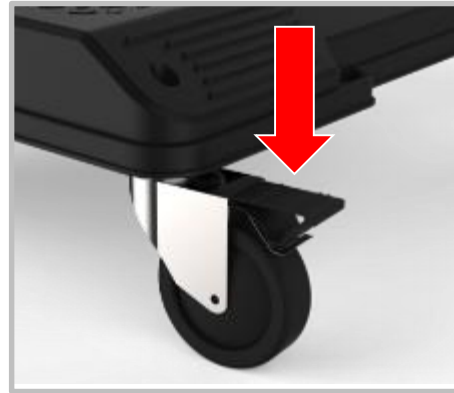

x2 Swivel With Brake Castor Wheels
| x2 swivel wheels

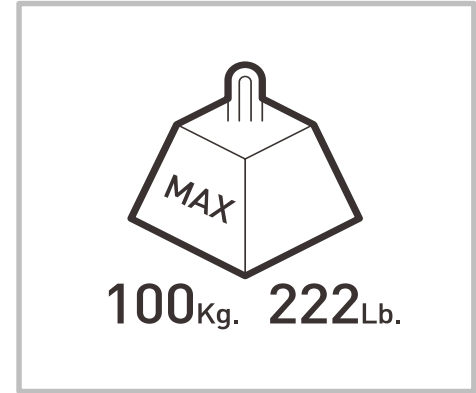

Max weight 100 kg

CANTILEVER SERIES

DESCRIPTION



Functionality and creativity go together in the Cantilever Series – versatile toolbox organizer solutions for professionals, DIYers and home craft enthusiasts. “I’ve tried many organizers. None have come close to this. It makes storage and transport easy.” The original alternative for storage of small parts and accessories, the clever Cantilever Series is a multi-level organizer and tool box that opens in a compact, efficient way while providing total access to all contents.



18" CANTILEVER TOOL BOX WITH 18 DIVIDERS

LOGISTIC DATA



PRODUCT

Dimensions 45,8x24x14,5 cm
Net weight 2,15 kg

PACK UNIT INFORMATION

Dimensions 46,5x25x59,5 cm
Pack size 4 

PALLET INFORMATION

Dimensions 120x80x200 cm
Pieces/pallet 96
Cartons/layer 6
Layers/pallet 4

CODIFICATION

EAN	ART. NR.	SAP CODE
7290005553561	17186819	237006



18" CANTILEVER TOOL BOX WITH 18 DIVIDERS

BENEFITS



Heavy-duty construction



Multiple sized removable bins allow for efficient tool and small parts organization



12 small and 6 deep bins



Metal latches keep the contents secure



The multi-level design offers easy access to contents



Cantilever system



Back legs provide optimum support and keep the organizer stable at all times



Long metal handle

22" CANTILEVER ORGANIZER

LOGISTIC DATA



PRODUCT

Dimensions 57,2x30,7x16,7 cm
Net weight 3,5 kg

PACK UNIT INFORMATION

Dimensions 57,7x31,2x51,2 cm
Pack size 3 

PALLET INFORMATION

Dimensions 120x80x171,5 cm
Pieces/pallet 48
Cartons/layer 2 / 2
Layers/pallet 5 / 3

CODIFICATION

EAN	ART. NR.	SAP CODE
7290004837259	17185073	237004



22" CANTILEVER ORGANIZER

BENEFITS



Heavy-duty construction



Multiple sized removable bins allow for efficient tool and small parts organization



15 small and 12 deep bins



Metal latches keep the contents secure



The multi-level design offers easy access to contents



Cantilever system



Back legs provide optimum support and keep the organizer stable at all times



Comfortable handle with a soft grip for easier transportation

22" CANTILEVER TOOL BOX

LOGISTIC DATA



PRODUCT

Dimensions 56,7x31,4x24,5 cm
Net weight 3,5 kg

PACK UNIT INFORMATION

Dimensions 57,2x32x49,5 cm
Pack size 2 

PALLET INFORMATION

Dimensions 120x80x213 cm
Pieces/pallet 40
Cartons/layer 2 / 2
Layers/pallet 6 / 4

CODIFICATION

EAN	ART. NR.	SAP CODE
7290103652951	17187311	237785



22" CANTILEVER TOOL BOX

BENEFITS



Heavy-duty construction



Multiple sized removable bins allow for efficient tool and small parts organization



9 small and 2 wide bins



Metal latches keep the contents secure



The multi-level design offers easy access to contents



Cantilever system



Back legs provide optimum support and keep the organizer stable at all times



Comfortable handle with a soft grip for easier transportation

ORGANIZER CANTI TRIO

LOGISTIC DATA



PRODUCT

Dimensions 53x20x23 cm
Net weight 2,6 kg

PACK UNIT INFORMATION

Dimensions 55x46,5x40,5 cm
Pack size 4 

PALLET INFORMATION

Dimensions 120x80x198,5 cm
Pieces/pallet 64
Cartons/layer 4
Layers/pallet 4

CODIFICATION

EAN	ART. NR.	SAP CODE
7290106922235	17198033	237788



ORGANIZER CANTI TRIO

BENEFITS



Heavy-duty construction



Integrated top organizers



Removable dividers allow you to customize the organizer to suit the job at hand



Metal latches keep the contents secure



The multi-level design offers easy access to contents



3-level cantilever system that opens horizontally



Back legs provide optimum support and keep the organizer stable at all times



Long metal handle

HAWK SERIES

DESCRIPTION



This tool box is for DIYers looking for a convenient tool hauling solution, and a high quality and practical storage box. With a large storage capacity and a heavy-duty handle with a soft grip, the tool box is easy to carry around, even if filled with bulky items and medium sized tools. Designed to last, the box has a durable construction and sturdy metal latches.



26" HAWK WITH ORGANIZER

LOGISTIC DATA



PRODUCT

Dimensions 66x28,7x26,6 cm
Net weight 3,85 kg

PACK UNIT INFORMATION

Dimensions 66,5x27,5x54,2 cm
Pack size 2 

PALLET INFORMATION

Dimensions 120x80x207,5 cm
Pieces/pallet 28
Cartons/layer 2
Layers/pallet 7

CODIFICATION

EAN	ART. NR.	SAP CODE
7290002166764	17181010	237784



26" HAWK WITH ORGANIZER

BENEFITS



Heavy-duty construction



Removable hand tool tray



Removable organizer with adjustable dividers



Metal latches keep the contents secure



Large container for big tools



Lockable



Anti-slip corners



Comfortable handle with a soft grip for easier transportation

19" FLAT TOP TOOL BOX

DESCRIPTION



A portable tool box for medium sized items.

Ideal for both professionals on the go and weekend warriors, this practical tool box provides plenty of space for larger tools and other accessories. A removable utility tray offers the perfect solution to move only the tools you need from the box to your work table. Made with a comfortable handle, the tool box is easy to carry around.



19" FLAT TOP TOOL BOX

LOGISTIC DATA



PRODUCT

Dimensions 48,6x26,2x24,5 cm
Net weight 1,78 kg

PACK UNIT INFORMATION

Dimensions 75x49x52 cm
Pack size 6 

PALLET INFORMATION

Dimensions 120x80x215,5 cm
Pieces/pallet 48
Cartons/layer 2
Layers/pallet 4

CODIFICATION

EAN	ART. NR.	SAP CODE
7290000229355	17331512	239991



19" FLAT TOP TOOL BOX

BENEFITS



Sturdy construction



Removable utility tray



Practical handle



Special latches

16" POWER TOOL BOX

DESCRIPTION



With this portable toolbox you can bring your power tools and bulky equipment anywhere with you, whether you're a professional or a DIY enthusiast. Wide enough to hold larger tools and compact enough to be easy to carry around, the box is practical and convenient. The wide carrying handle makes transportation a breeze, as it is placed centrally to provide perfect balance while walking.



16" POWER TOOL BOX

LOGISTIC DATA



PRODUCT

Dimensions 41,9x32,7x20,5 cm
Net weight 1,3 kg

PACK UNIT INFORMATION

Dimensions 42,4x65,5x42 cm
Pack size 4 

PALLET INFORMATION

Dimensions 120x80x224 cm
Pieces/pallet 64
Cartons/layer 2 / 2
Layers/pallet 5 / 3

CODIFICATION

EAN	ART. NR.	SAP CODE
7290103656669	17191708	238279



16" POWER TOOL BOX

BENEFITS



Wide toolbox design, for bulky items and large hand equipment



Removable tray for accessories



Safe metal latches

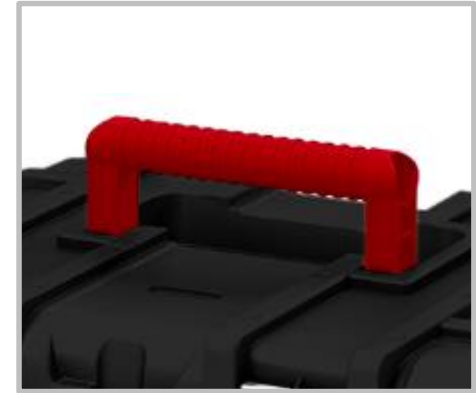

Portable thanks to the wide and centrally-placed carrying handle.

TECHNICIAN BOX

DESCRIPTION

Protect your tools from the outside and the inside with the durable Technician Case. The sturdy outer case offers high resistance to environmental conditions, ensuring the long life of your tools, and the liner cushions the case's contents for added protection. Tough and protective on the outside, soft and supportive on the inside, the Technician Case features an integrated flexible tool bar and removable organizer that keep your frequently-used tools within easy reach.



TECHNICIAN BOX

LOGISTIC DATA



PRODUCT

Dimensions 48x38x17,5 cm
Net weight 3,4 kg

PACK UNIT INFORMATION

Dimensions 48,5x71,7x39,1 cm
Pack size 4 

PALLET INFORMATION

Dimensions 120x80x210 cm
Pieces/pallet 40
Cartons/layer 2
Layers/pallet 5

CODIFICATION

EAN	ART. NR.	SAP CODE
7290103667832	17198036	237003



TECHNICIAN BOX

BENEFITS



Heavy-duty construction



Removable and customizable dividers lets you create a toolbox that is uniquely yours and suits your needs



Integrated tool bar provides easy and quick access to the more frequently used hand tools



Metal latches keep the contents secure



Metal lid stopper



The removable small parts organizer comes with convenient lid, so you can use it separately when needed



Lockabe



Carrying handle

MASTERLOADER

DESCRIPTION

The Sliding Tool Chest is a great choice for professionals looking for a compact and mobile chest that can hold various types of tools, both large and small. An integrated organizer with six removable bins offers plenty of space for small parts, while the hand tool compartment with a divider is perfect for small hand tools. The chest opens horizontally on ball bearing slides, and can be transported anywhere easily thanks to the rubber wheels and the handle with a soft grip.



MASTERLOADER

LOGISTIC DATA



PRODUCT

Dimensions 61,6x37,8x41,5 cm
Net weight 5,9 kg

PACK UNIT INFORMATION

Dimensions 62,1x38,3x84 cm
Pack size 2 

PALLET INFORMATION

Dimensions 120x80x181 cm
Pieces/pallet 16
Cartons/layer 4
Layers/pallet 2

CODIFICATION

EAN	ART. NR.	SAP CODE
7290103656539	17191709	237787



MASTERLOADER

BENEFITS



Ball bearing slide mechanism allows for easy access to all compartments by sliding the top units horizontally



Mobile tool box for easy and comfortable transportation



2 integrated organizers, one with a clear polycarbonate lid



4 small and 2 wide bins



Rubber wheels



Foldable handle with soft grip



Central locking system protects the contents at all times



Lockable

DRAWERS TOOL CHEST SYSTEM

DESCRIPTION



Different variations possible.
Customize your own work space and storage area.

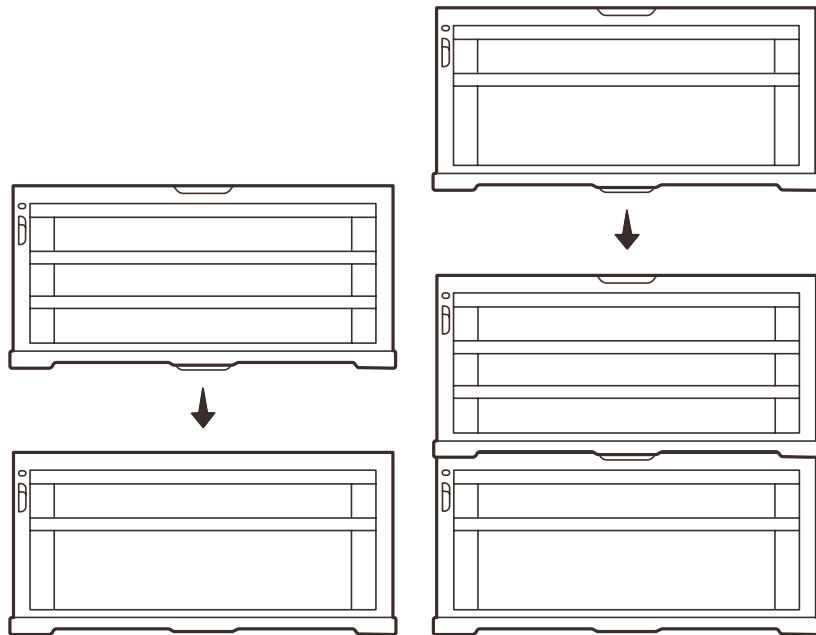

6 DRAWERS TOOL CHEST SET

LOGISTIC DATA



PRODUCT

Dimensions 56,2x28,9x74,2 cm
Net weight 13,2 kg

PACK UNIT INFORMATION

Dimensions 57,2x30x75 cm
Pack size 1 cardboard base

PALLET INFORMATION

Dimensions 120x80x163 cm
Pieces/pallet 8
Cartons/layer 4
Layers/pallet 2

CODIFICATION

EAN	ART. NR.	SAP CODE
7290106928770	17201228	237786



5 DRAWERS TOOL CHEST SET

LOGISTIC DATA



PRODUCT

Dimensions 56,2x28,9x50,2 cm
Net weight 10 kg

PACK UNIT INFORMATION

Dimensions 57,2x30x50,7 cm
Pack size 1 cardboard base

PALLET INFORMATION

Dimensions 120x80x195 cm
Pieces/pallet 14
Cartons/layer 4
Layers/pallet 3 + 2 pack

CODIFICATION

EAN	ART. NR.	SAP CODE
7290106926172	17199301	237007



3 DRAWERS TOOL CHEST SET

LOGISTIC DATA



PRODUCT

Dimensions 56,2x28,9x26,2 cm
Net weight 4,8 kg

PACK UNIT INFORMATION

Dimensions 57,2x30x52,2 cm
Pack size 2 

PALLET INFORMATION

Dimensions 120x80x184 cm
Pieces/pallet 36
Cartons/layer 2 / 2
Layers/pallet 7 / 4

CODIFICATION

EAN	ART. NR.	SAP CODE
7290106926134	17199302	237791



2 DRAWERS TOOL CHEST SET

LOGISTIC DATA



PRODUCT

Dimensions 56,2x28,9x26,2 cm
Net weight 3,9 kg

PACK UNIT INFORMATION

Dimensions 57,2x30x52,2 cm
Pack size 2 

PALLET INFORMATION

Dimensions 120x80x184 cm
Pieces/pallet 36
Cartons/layer 2 / 2
Layers/pallet 7 / 4

CODIFICATION

EAN	ART. NR.	SAP CODE
7290106926158	17199303	237790



DRAWER SYSTEM

BENEFITS

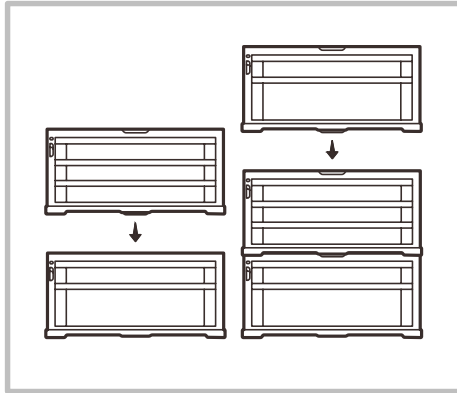

Modular drawer system



Integrated carry handles



Safe and versatile stacking thanks to side latches



Central locking system



Deep drawer with removable dividers for large tools



Removable small parts bins



Metal ball bearing slides



Wheels allow easy and comfortable transport

FOLDING WORK TABLE

DESCRIPTION



Creating a professional work area in any room is easy thanks to the versatile and completely portable Folding Work Table. Designed for professionals on the go, this table features sturdy legs and set up system that takes seconds. Lightweight and heavy-duty at the same time, the table can handle weights of up to 1000 lbs/453 kg. Two 12" clamps are included, for more practicality.



FOLDING WORK TABLE

LOGISTIC DATA



PRODUCT

Dimensions 85x55,5x11,2 cm
Net weight 12,25 kg

PACK UNIT INFORMATION

Dimensions 85x55,5x11,5 cm
Pack size 1 cardboard sleeve

PALLET INFORMATION

Dimensions 120x80x128 cm
Pieces/pallet 20
Cartons/layer 2
Layers/pallet 10

CODIFICATION

EAN	ART. NR.	SAP CODE
7290000230825	17182239	237005



FOLDING WORK TABLE

BENEFITS



Lightweight folding table with an integrated carrying handle for easy transportation



Wide work space 85x55 cm



Removable clamps included



12" clamps that can be installed both horizontally and vertically, to suit almost any job



Solid metal legs ensure stable construction



75,5 cm tall while extended

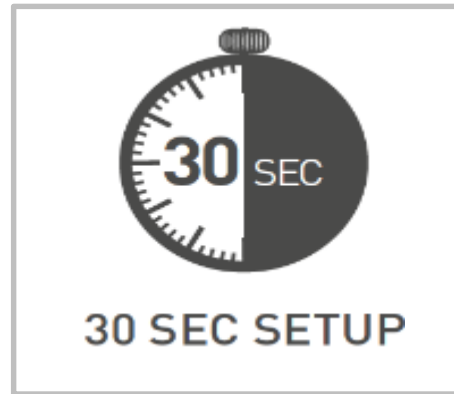

Easy to set up in just seconds with no assembly needed, the table helps to create a professional work area almost instantly

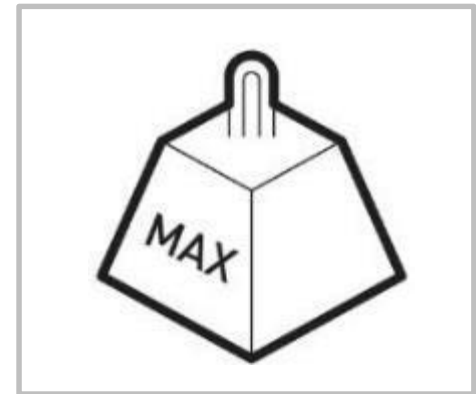

453 kg weight capacity makes the table ideal for a wide range of jobs

FOLDING WORK TABLE

BENEFITS



Unique quick opening system device – 30 seconds setup!



KETER[®]

CLASSIC



MOBILE TOOL CHEST

DESCRIPTION



An ideal choice for any weekend warrior, this toolbox has a conveniently mobile design. You can take with you all the tools you need for a job and store them in one place. The box is ideal for bulky tools, while the organizers are perfect for smaller sized tools and parts. The extra organizer can be easily removed when needed. Easy to transport, this mobile toolbox features rubber-track wheels and a foldable handle.



MOBILE TOOL CHEST

LOGISTIC DATA



PRODUCT

Dimensions 42,5x31,2x62 cm
Net weight 4 kg

PACK UNIT INFORMATION

Dimensions 42,5x31,2x62 cm
Pack size 1 

PALLET INFORMATION

Dimensions 120x80x204 cm
Pieces/pallet 18
Cartons/layer 6
Layers/pallet 3

CODIFICATION

EAN	ART. NR.	SAP CODE
3253929000195	17181812	231805



MOBILE TOOL CHEST

BENEFITS



Heavy-duty construction



Two part tool chest – easy access to content



Two integrated lid organizers for small accessories



Removable small parts organizer



7" rubber coated wheels ensure easy transportation



Foldable handle that locks in place ensure efficient and comfortable transportation



Carrying handle on toolbox



Lockable

CLICK BINS

DESCRIPTION



Make organization easy with CLICK BINS 0,45L, 1,3L and 2,8L capacity. With its open-top design you can easily access your items, and with its stackable design you can stack multiple stacking bins for a comprehensive storage option with a minimal footprint.



CLICK BIN SMALL SET 4 PCS. 0.45 L

LOGISTIC DATA



PRODUCT

Dimensions 15,5x11x8,5 cm
Net weight 0,28 kg

PACK UNIT INFORMATION

Dimensions 34x32x24 cm
Pack size 12 

PALLET INFORMATION

Dimensions 120x80x160 cm
Pieces/pallet 432
Cartons/layer 6
Layers/pallet 6

CODIFICATION

EAN	ART. NR.	SAP CODE
7290103660857	17197117	230793



CLICK BIN MEDIUM SET 4 PCS. 1.3 L

LOGISTIC DATA

KETER[®]

PRODUCT

Dimensions 23x16x13,5 cm
Net weight 0,62 kg

PACK UNIT INFORMATION

Dimensions 33x24x50,8 cm
Pack size 8 

PALLET INFORMATION

Dimensions 120x80x164 cm
Pieces/pallet 240
Cartons/layer 10
Layers/pallet 3

CODIFICATION

EAN	ART. NR.	SAP CODE
7290005852881	17193661	230792



CLICK BIN LARGE 2.8 L

LOGISTIC DATA

KETER[®]

PRODUCT

Dimensions 31,5x22x16 cm
Net weight 0,32

PACK UNIT INFORMATION

Dimensions 32,5x23x46 cm
Pack size 12 

PALLET INFORMATION

Dimensions 120x80x198,2 cm
Pieces/pallet 528
Cartons/layer 11
Layers/pallet 4

CODIFICATION

EAN	ART. NR.	SAP CODE
7290005828898	17193662	230939



2
YEAR
WARRANTY

CLICK BINS

BENEFITS



4 pins for firm stacking



Large labeling area with labels included



Wall mountable



Includes handle for easy mobility

STACK N' ROLL

The **STACK N' ROLL** system's customers base is diverse in terms of age and interests - From Light DIY to heavy DIY. These customers mainly are Budget-conscious tradesmen.

STACK N' ROLL is a dual-concept that combines a stationary "at home" and a mobile "on the move" solution. It provides an excellent, easy-to-create organization for a garage / utility room, and easy mobility, when you need to work outdoors.



STACK N' ROLL

PLANOGRAM.

STACK N' ROLL
VISION

2024



STACK & ROLL

VISION 2024



STACK N' ROLL

1. Metal telescopic handle.
2. Modular system connectivity.
3. Heavy duty latches.
4. 7" wheels.
5. Tray in the toolbox that fits also to the cart.
6. Polycarbonate clear lid.
7. Multiple size removable bins.



PRODUCT BENEFITS

01 _____



02 _____



03 _____



04 _____



05 _____



06 _____



07 _____



STACK N' ROLL

1. Metal telescopic handle.
2. Ergonomic handle design with top button.
3. System modular connectivity.
4. 7" wheels.
5. Side grips for carrying the product.
6. Cross system tray – toolbox tray fits also to the cart.
7. Accessories pocket.



PRODUCT BENEFITS

01 _____



02 _____



03 _____



04 _____



05 _____



06 _____



07 _____



STACK N' ROLL

1. Carrying top handle with over-mold.
2. Toggle metal latches.
 - Durable.
 - Locking assurance – latch force and sound closing indication.
 - Ergonomic tough point.
3. Cross system tray – toolbox tray fits also to the cart.
4. System modular connectivity.
5. Lockable.



PRODUCT BENEFITS

01 _____



02 _____



03 _____



04 _____



STACK 'N' ROLL

1. Carrying top handle with over-mold.
2. Toggle metal latches.
 - Durable.
 - Locking assurance – latch force and sound closing indication.
 - Ergonomic tough point.
3. Stack'n Roll system stackable, interlocking modular connectivity.
4. Cross system, interchangeable bins.
5. Clear polycarbonate lid with anti-migration structure.



PRODUCT BENEFITS

01 _____



02 _____



03 _____



04 _____



STACK N' ROLL

PRODUCT DATA

Item Dim.: 52.5 x 41.1 x 69.5 cm

PACKAGING TYPE

Packaging Data: 1 pcs in carton
Dim.: 53.7 x 42.3 x 71.2 cm



STACK N' ROLL

PRODUCT DATA

Item Dim.: 52.5 x 41.1 x 56.8 cm

PACKAGING TYPE

Packaging Data: 2 pcs in carton
Dim.: 53.7 x 46.7 x 71.7 cm



STACK N' ROLL

PRODUCT DATA

Item Dim.: 52.5 x 34.5 x 26 cm

PACKAGING TYPE

Packaging Data: 2 pcs in carton
Dim.: 53.5 x 35.5 x 52 cm



STACK N' ROLL

PRODUCT DATA

Item Dim.: 51.5 x 34.5 x 11.5 cm

PACKAGING TYPE

Packaging Data: 4 pcs in Display
Dim.: 53.7 x 43.7 x 36 cm



KETER[®]

DIY





DIY LOGISTIC DATA



HEROBOX 13"



PRODUCT

Dimensions 33x20x16 cm
Net weight 0,47 kg

PACK UNIT INFORMATION

Dimensions 30x20x32 cm
Pack size 2 

PALLET INFORMATION

Dimensions 120x80x179cm
Pieces/pallet 120
Cartons/layer 12
Layers/pallet 5

EAN	DUN	EUROCODE	SAP CODE	COLOR
3253922898003	03253920289803	02898-888-02	193601	Black/Red



DIY
LOGISTIC DATA



HEROBOX 16"



PRODUCT

Dimensions 39,5x23x22 cm
Net weight 0,9 kg

PACK UNIT INFORMATION

Dimensions 39x22,8x44 cm
Pack size 2 

PALLET INFORMATION

Dimensions 120x80x186 cm
Pieces/pallet 80
Cartons/layer 10
Layers/pallet 4

EAN	DUN	EUROCODE	SAP CODE	COLOR
3253922899031	03253920289933	02899-888-02	193603	Black/Red

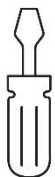

DIY LOGISTIC DATA



HEROBOX 16"+13"



PRODUCT

Dimensions 39,5x23x22 cm
Net weight 1,36 kg

PACK UNIT INFORMATION

Dimensions 39x23,5x44,5 cm
Pack size 2 

PALLET INFORMATION

Dimensions 120x80x191 cm
Pieces/pallet 80
Cartons/layer 10
Layers/pallet 4

EAN	DUN	EUROCODE	SAP CODE	COLOR
3253922897006	03253920289704	02897-888-00	195477	Black/Red

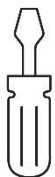

DIY LOGISTIC DATA



DRAWER CABINET



PRODUCT

Dimensions 29x17x27 cm
Net weight 1,43 kg

PACK UNIT INFORMATION

Dimensions 56,3x37,8x31,8 cm
Pack size 4

PALLET INFORMATION

Dimensions 120x80x170 cm
Pieces/pallet 80
Cartons/layer 4
Layers/pallet 5

EAN	DUN	EUROCODE	SAP CODE	COLOR
3253927752003	03253924628011	07752-498-00	159561	Dark Grey



DIY LOGISTIC DATA



PREMIUM 16"



PRODUCT

Dimensions 41,4x22,3x20,5 cm
Net weight 1,404 kg

PACK UNIT INFORMATION

Dimensions 41,5x39,5x61,5 cm
Pack size 6

PALLET INFORMATION

Dimensions 120x80x1995 cm
Pieces/pallet 72
Cartons/layer 4
Layers/pallet 3

EAN	DUN	EUROCODE	SAP CODE	COLOR
3253922925006	03253928211011	02925-976-00	159622	Grey



DIY LOGISTIC DATA



PREMIUM 20"



PRODUCT

Dimensions 50x25x25 cm
Net weight 2,187 kg

PACK UNIT INFORMATION

Dimensions 50x25x102,5 cm
Pack size 4

PALLET INFORMATION

Dimensions 120x80x1915 cm
Pieces/pallet 40
Cartons/layer 3
Layers/pallet 4

EAN	DUN	EUROCODE	SAP CODE	COLOR
3253922934022	03253929261060	02934-976-42	157705	Grey



DIY LOGISTIC DATA



Step Stool



PRODUCT

Dimensions 48,6x17,2x63 cm
Net weight 3,115 kg

PACK UNIT INFORMATION

Dimensions 50x18x64 cm
Pack size 1

PALLET INFORMATION

Dimensions 120x80x1900 cm
Pieces/pallet 33
Cartons/layer 12
Layers/pallet 2 + 9 pack

EAN	DUN	EUROCODE	SAP CODE	COLOR
3253928605025	03253928605025	08605-155-00	155160	Dark grey/red



THANK YOU.

