



# 2024

## CATALOGUE

---

### TOOL STORAGE

---



# CONTENTS

**2**

KETER ROC

**4**

PRO GEAR SYSTEM

**24**

KETER

**25**

CONNECT SYSTEM

**35**

STACK N ROLL

**43**

DRAWER SYSTEM

**47**

CANTILEVERS AND  
ORGANIZERS

**55**

MOBILE STORAGE

**61**

TOOLBOXES

**69**

WORKBENCHES  
AND SAWHORSES

**75**

PRODUCT INDEX

KETER<sup>®</sup>  
**ROC**  
PRO GEAR SYSTEM

**25**  
YEAR  
GUARANTEE





# 01

## PRO GEAR SYSTEM

**The ROC Pro Gear modular system is loaded with rugged professional features for a job site or workshop.**

Equipped with tough 9" wheels and modular base units, the ROC Pro Gear system makes it easy to transport whatever gear you need to complete the task at hand. It's the most flexible, functional, and efficient system for all your pro needs.

# PRO GEAR SYSTEM

## PRO GEAR SYSTEM

Item# 17212618



Lid structured for easy accessibility



Side-locking metal handles



9" wheels



IP65 water and dust resistance



Heavy-duty construction

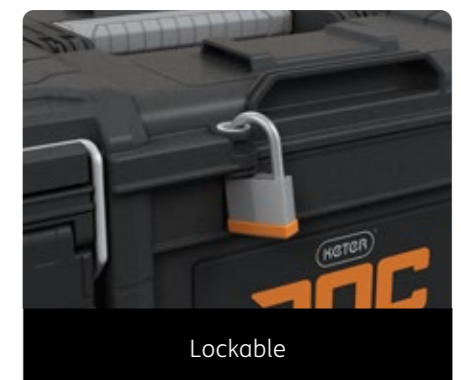

Lockable



Attach & detach telescopic handle with wheels



Half footprint connectivity



Mountable (included with Power Tool Case and Toolbox)

# PRO GEAR SYSTEM

## PRO GEAR CRATE

Item# 17202245



Heavy-duty construction



Metal side handles for carrying



Side handles are also connecting latches

## PRO GEAR ORGANIZER

Item# 17206659

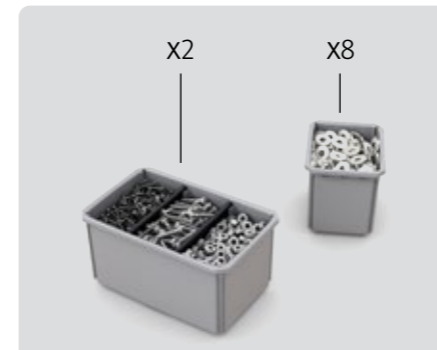

Removable bins in multiple sizes



Unbreakable polycarbonate lid



Integrated water seal

# PRO GEAR SYSTEM

## PRO GEAR COMPACT ORGANIZER

Item# 17211900

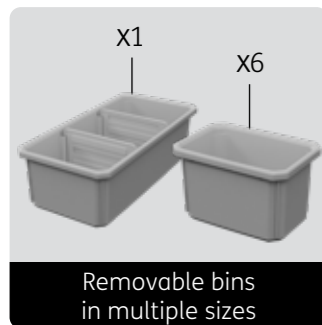

Removable bins in multiple sizes



Unbreakable polycarbonate lid



Integrated water seal



Mountable

## PRO GEAR POWER TOOL CASE

Item# 17211899



Lockable durable latches

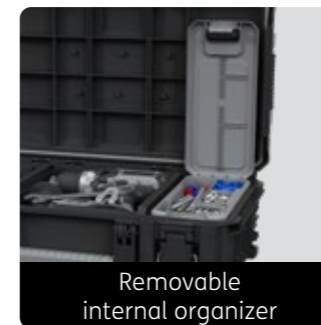

Removable internal organizer

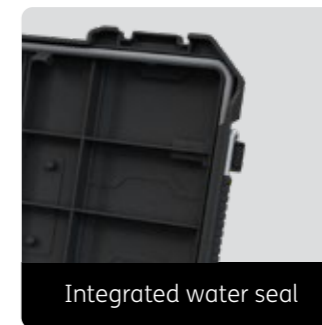

Integrated water seal



Mountable

# PRO GEAR SYSTEM

## PRO GEAR TOOLBOX

Item# 17211898



Lockable durable latches



Removable internal organizer

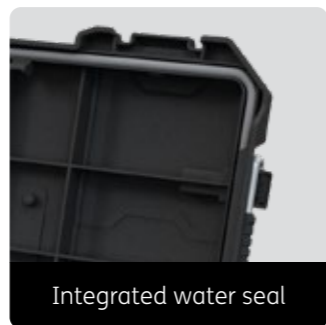

Integrated water seal



Mountable

## PRO GEAR XL TOOLBOX

Item# 17211901

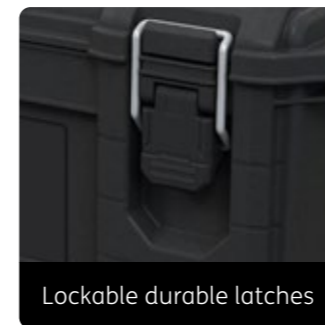

Lockable durable latches

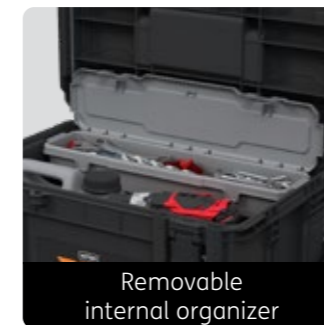

Removable internal organizer

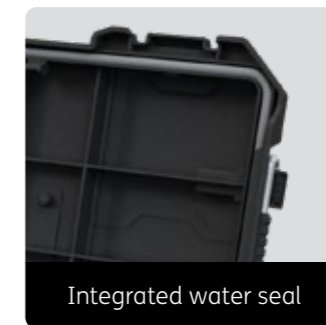

Integrated water seal

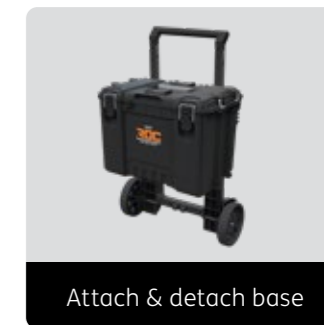

Attach & detach base



# PRO GEAR SYSTEM

## XL DRAWERS

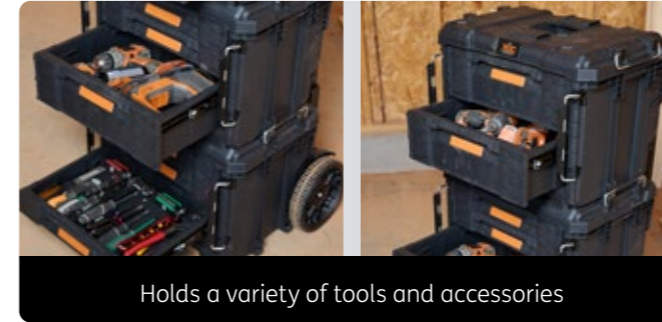

Holds a variety of tools and accessories



Removable dividers



Attach & detach base



Metal ball bearing drawer slides



Mountable

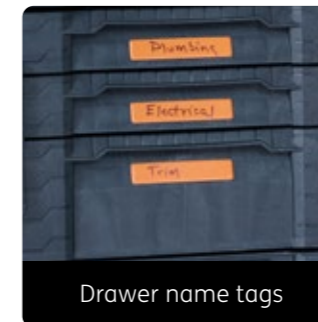

Drawer name tags

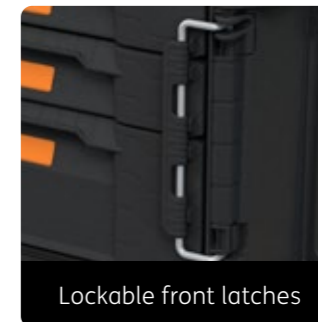

Lockable front latches

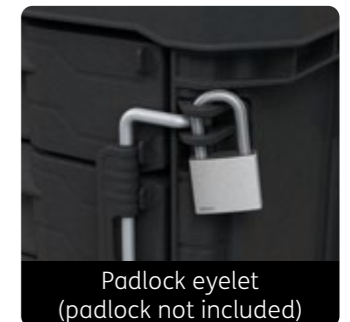

Padlock eyelet (padlock not included)

## XL 3 DRAWERS

Item# 17212468



## XL 2 DRAWERS

Item# 17212781



## XL 3 DRAWERS CART

Item# 17212783



## XL 2 DRAWERS CART

Item# 17212784



# PRO GEAR SYSTEM

## PRO GEAR CART

Item# 17211897



Lockable durable latches



Removable internal organizer

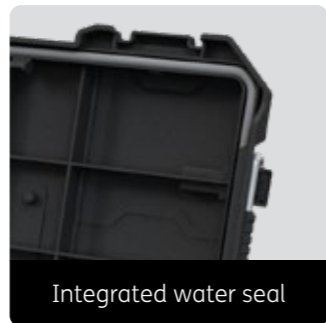

Integrated water seal



9" wheels

## 28" ROLLING JOB BOX

Item# 17210204



Telescopic handle



Portable tray



4" all-terrain wheels

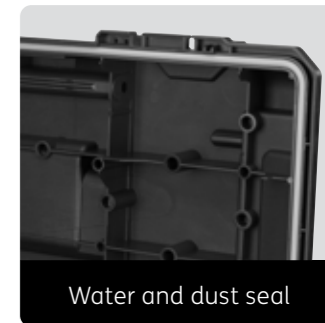

Water and dust seal

# PRO GEAR SYSTEM

CUSTOMIZABLE  
BUILD YOUR SYSTEM, TAKE THE GEAR YOU NEED



# WORKBENCHES AND SAWHORSES



## LUMBERJACK ADJUSTABLE SAWHORSE

Item# 17203039

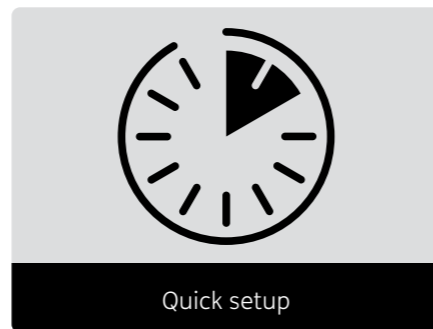
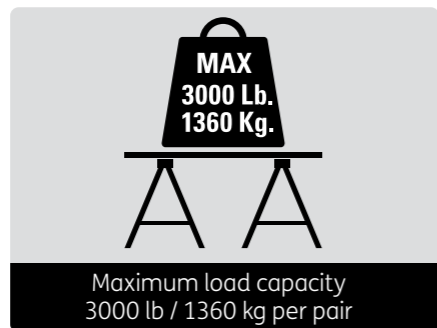
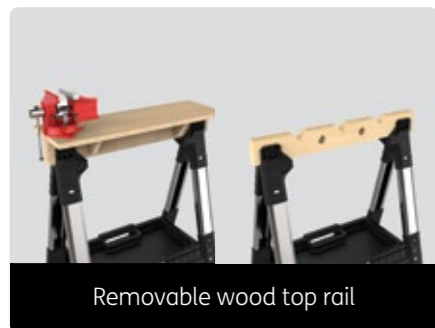

## HYBRID PORTABLE WORKBENCH

Item# 17213476

**COMING SOON 2025**

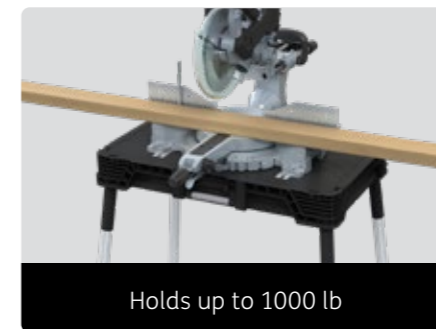
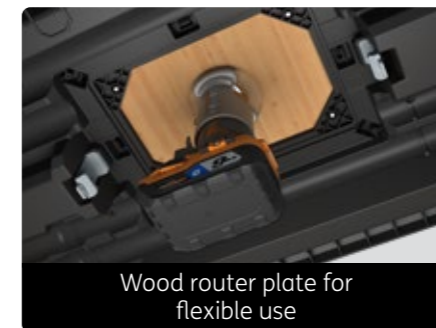

KETER®  
**ROC**  
PRO GEAR SYSTEM





# 02

## CONNECT SYSTEM

**A natural choice for professionals and weekend warriors who want easy access to all their tools and accessories.** Ultimate tool storage and small parts organizers for serious DIYers. Want to add it to the Connect rolling system? Easy. Just stack it. Click it. And you're ready to go.

# CONNECT SYSTEM

## CONNECT ROLLING SYSTEM

Item# 17203038



Easy Connect mechanism



Durable rubber wheels



Removable bins in multiple sizes



Unbreakable polycarbonate lid



Dual support stabilizer legs



Telescopic metal handle

## CONNECT ORGANIZER

Item# 17205287

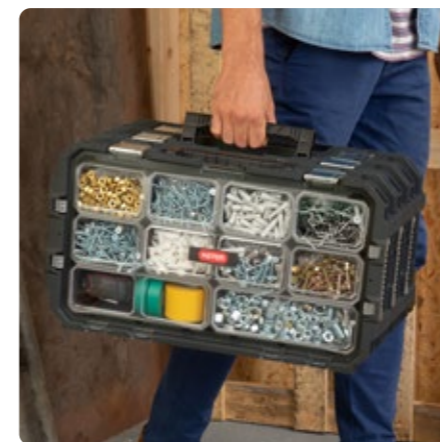

Removable bins in multiple sizes



Unbreakable polycarbonate lid

# CONNECT SYSTEM

## CONNECT TOOLBOX

Item# 17205288



Metal lid stopper

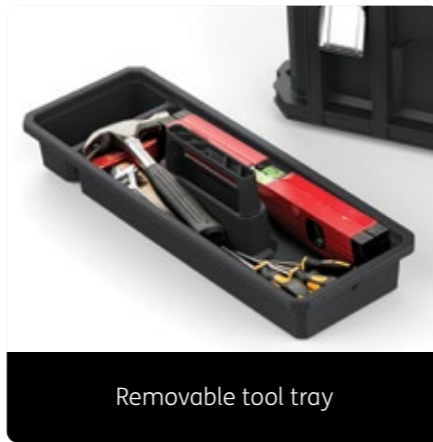

Removable tool tray

## CONNECT CANTILEVER ORGANIZER

Item# 17203103

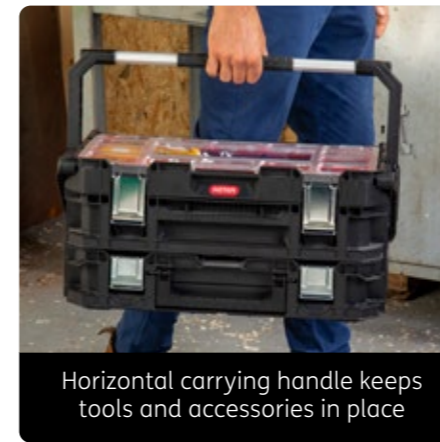

Horizontal carrying handle keeps tools and accessories in place

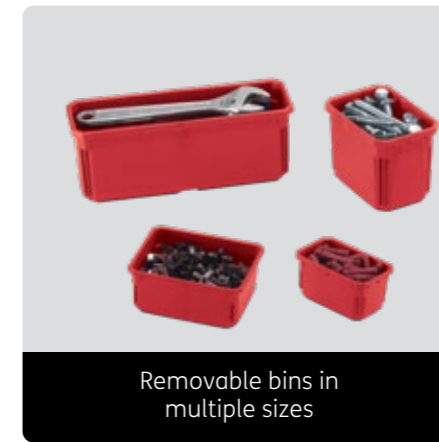

Removable bins in multiple sizes

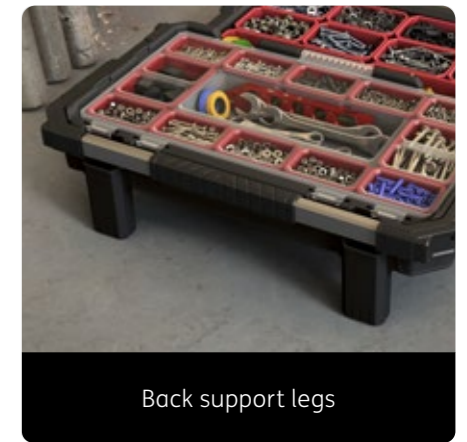

Back support legs



# CONNECT SYSTEM

## CONNECT CANTILEVER TOOLBOX

Item# 17203104



Unbreakable polycarbonate lid

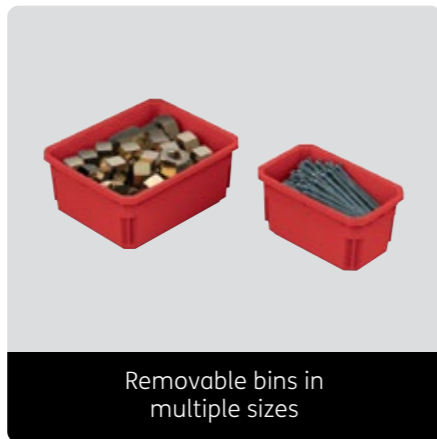

Removable bins in multiple sizes



Back support legs

## CONNECT TROLLEY

Item# 17205514

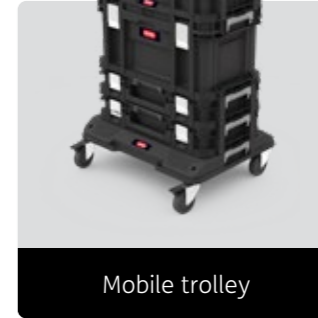

Mobile trolley

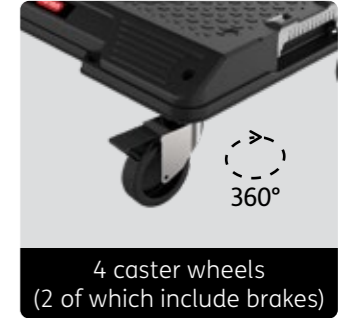

4 caster wheels (2 of which include brakes)

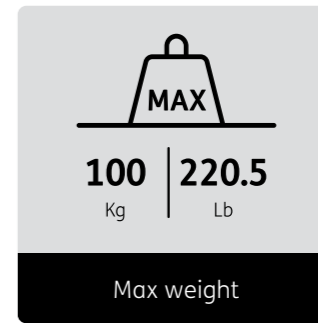

MAX  
100 | 220.5  
Kg | Lb

Max weight

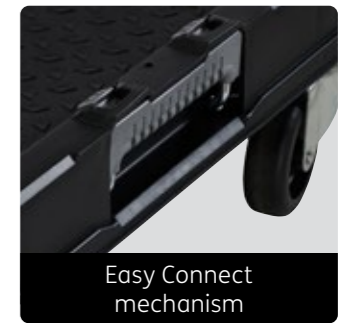

Easy Connect mechanism

## CONNECT CADDY

Item# 17206124

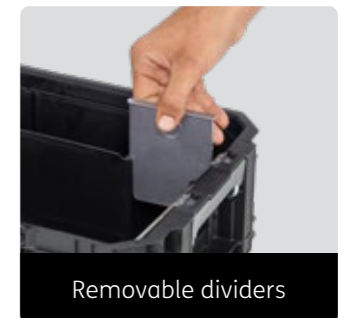

Removable dividers



Stackable

# CONNECT SYSTEM

## CONNECT DRAWERS

Item# 17208564

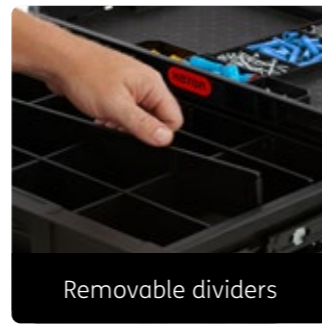
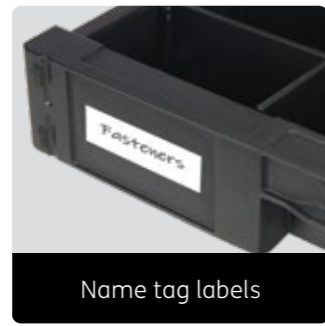

## CONNECT CART + ORGANIZER

Item# 17205661

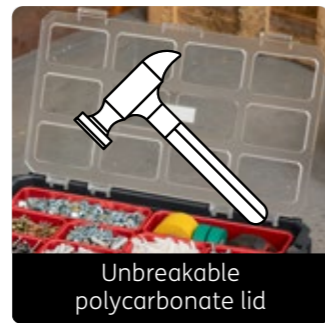
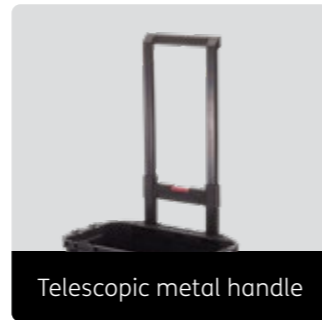

## CUSTOMIZABLE





# 03

## STACK N ROLL SYSTEM

Get organized at home with this incredibly versatile and lightweight family of mobile tool storage solutions, which keeps your tools protected and easy to find when you need them. Convenient accessories and different-sized connectable storage units can be easily customized and moved to wherever you want to work around the house, so you can work the way that works best for you.

# STACK N ROLL SYSTEM

## STACK N ROLL SYSTEM

Item# 17210365



Stackable, interlocking modular connectivity



Durable 7" wheels for stable transportation

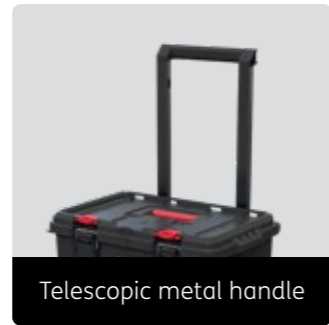

Telescopic metal handle

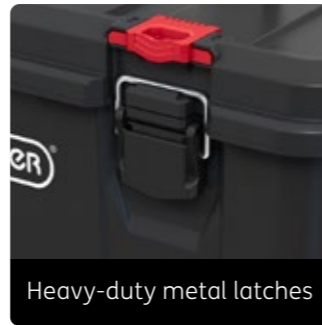

Heavy-duty metal latches

## STACK N ROLL ORGANIZER

Item# 17210772



Lightweight and easy to carry

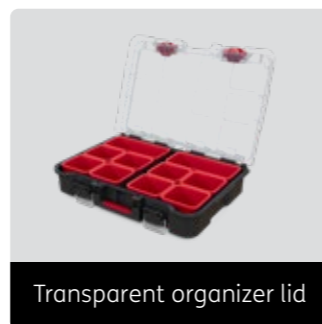

Transparent organizer lid

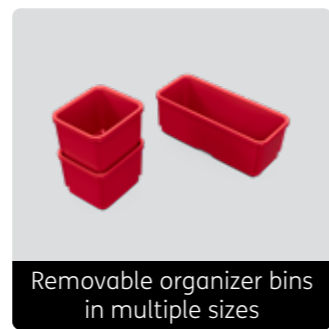

Removable organizer bins in multiple sizes



Padlock eyelet for lockability (padlock not included)

## STACK N ROLL TOOLBOX

Item# 17210774

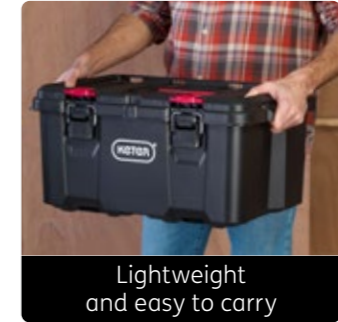

Lightweight and easy to carry

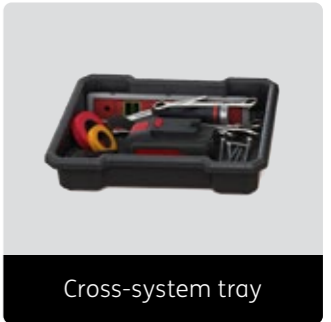

Cross-system tray

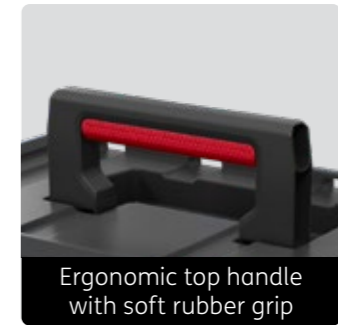

Ergonomic top handle with soft rubber grip

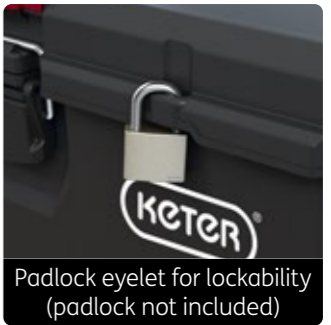

Padlock eyelet for lockability (padlock not included)

## STACK N ROLL CART

Item# 17210777

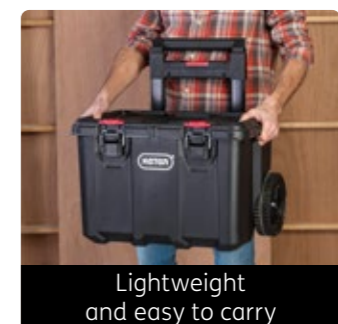
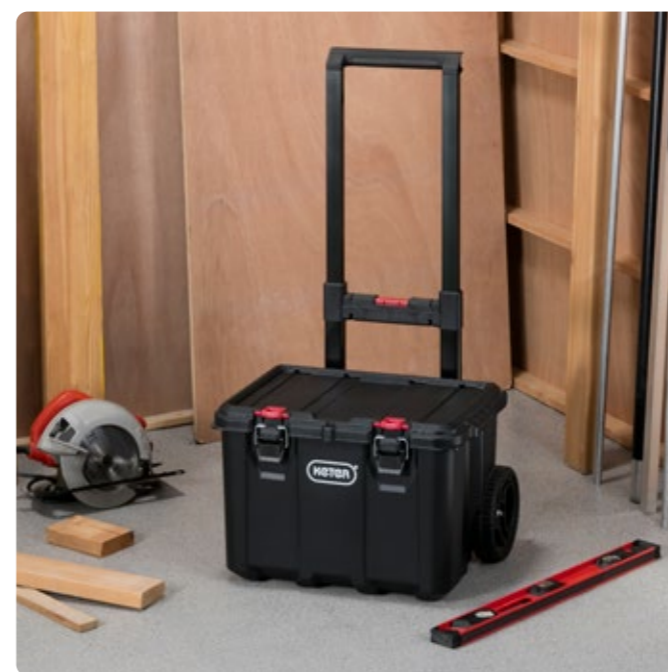

Lightweight and easy to carry



Durable 7" wheels for stable transportation

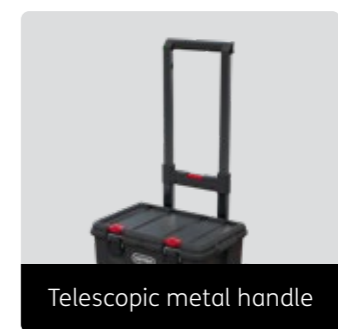

Telescopic metal handle

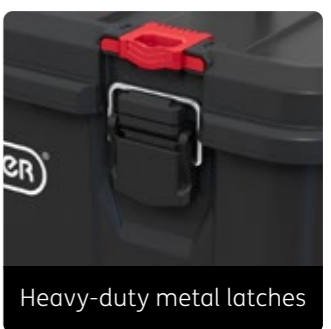

Heavy-duty metal latches

# STACK N ROLL SYSTEM

## STACK N ROLL 3 ORGANIZER SET

Item# 17210831

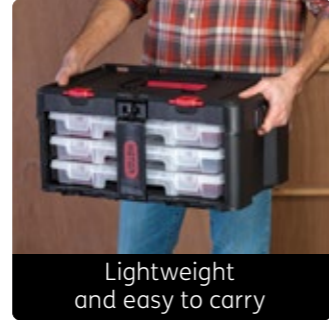

Lightweight and easy to carry



Transparent organizers for content visibility



Polycarbonate locking strip device

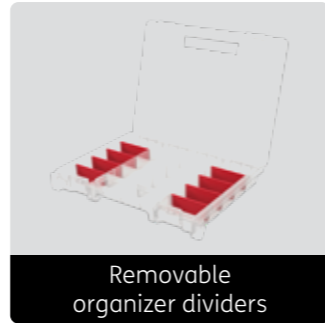

Removable organizer dividers

## STACK N ROLL POWER TOOL CASE

Item# 17211432

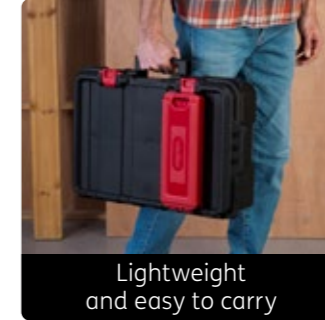

Lightweight and easy to carry

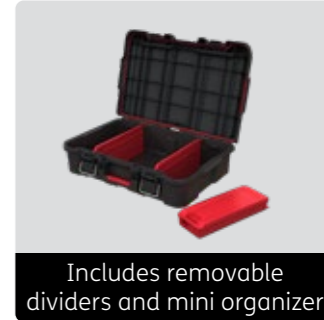

Includes removable dividers and mini organizer



IP54 seal protects contents from dust and moisture

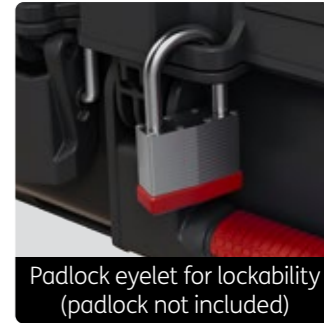

Padlock eyelet for lockability (padlock not included)

## STACK N ROLL 2 DRAWER UNIT

Item# 17210832



Lightweight and easy to carry



Full drawer extension for complete view



Polycarbonate locking strip device

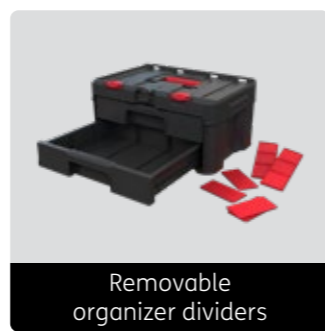

Removable organizer dividers

## STACK N ROLL HALF ORGANIZER

Item# 17211433

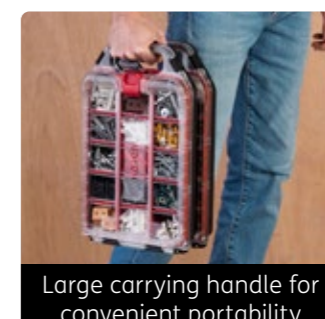
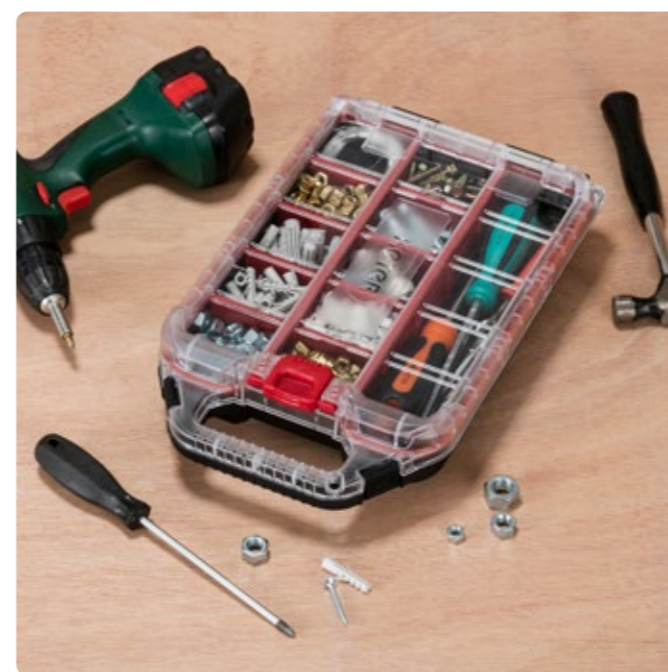

Large carrying handle for convenient portability

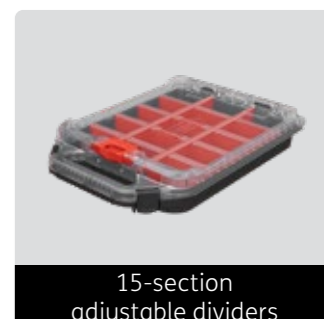

15-section adjustable dividers

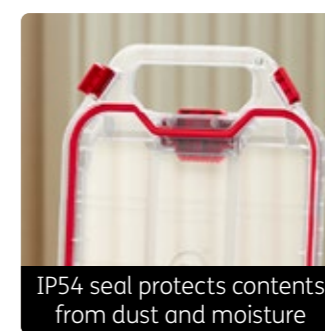

IP54 seal protects contents from dust and moisture

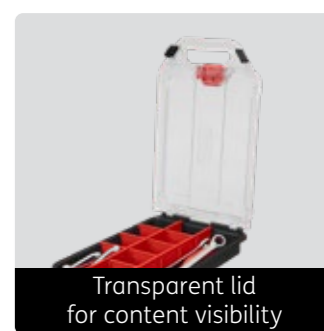

Transparent lid for content visibility

# STACK N ROLL SYSTEM

## STACK N ROLL SYSTEM WITH POWER TOOL CASE

Item# 17211896



Stackable, interlocking modular connectivity



Durable 7" wheels for stable transportation



Telescopic metal handle



Heavy-duty metal latches

## STACK N ROLL CLEAR ORGANIZER

Item# 17212328



Transparent organizer lid



Removable dividers

AVAILABLE UNDER

**WORX**

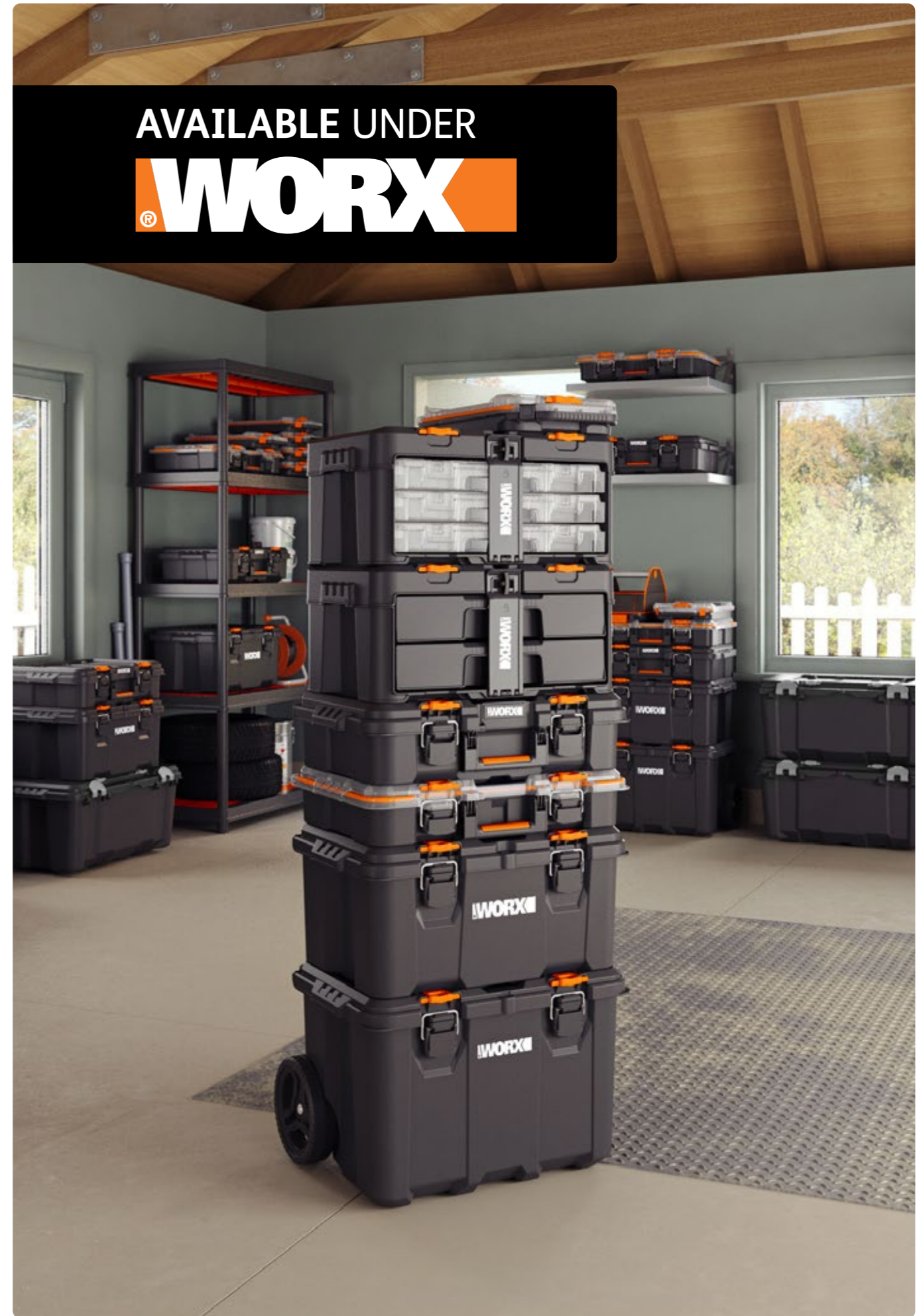



# 044

## DRAWER SYSTEM

**Versatile drawer storage unit on wheels.**

This spacious drawer storage unit provides plenty of space for smaller and bulkier items, making it a great choice for professionals and weekend warriors. Built-in swivel wheels give you the freedom to move your tools and accessories to wherever you're working.

# DRAWER SYSTEM



## 2 DRAWER TOOL CHEST

Item# 17199303



## 3 DRAWER TOOL CHEST

Item# 17199302



## 5 DRAWER TOOL CHEST

Item# 17199301



## 7 DRAWER TOOL CHEST

Item# 17200395

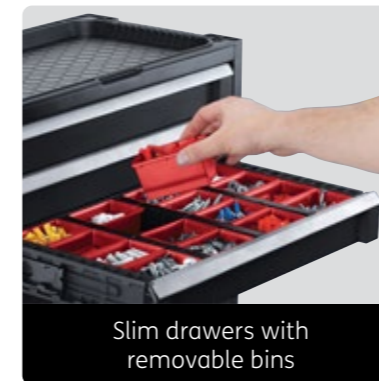

Slim drawers with removable bins



Swivel casters



Removable divider



Sturdy latch and lock connecting system

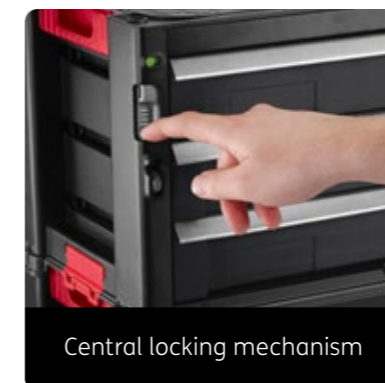

Central locking mechanism







# 05

## CANTILEVERS AND ORGANIZERS

**Small parts organizers for professionals on the go.**

Getting the job done efficiently depends on having exactly the small parts you need, when you need them! These professional organizers keep your small parts and accessories in perfect condition and perfectly accessible from job to job.

# CANTILEVERS AND ORGANIZERS

## CANTILEVER ORGANIZER 22

Item# 17185073

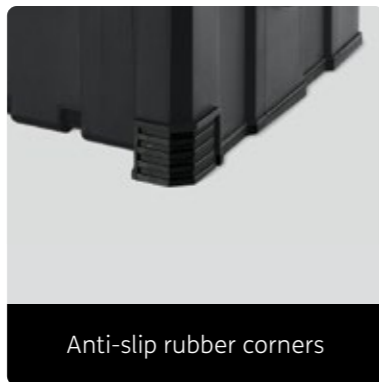
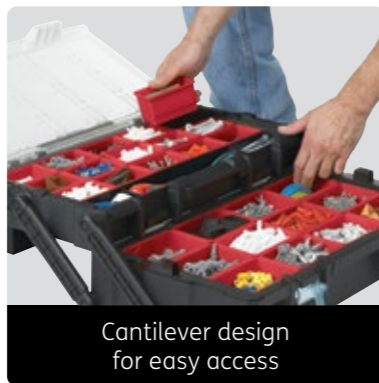
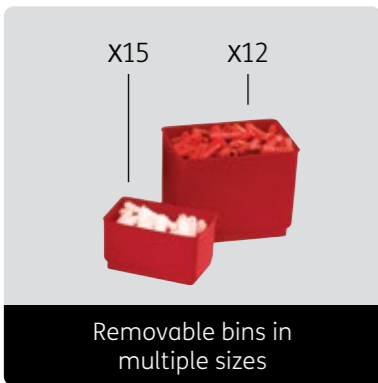

## CANTILEVER TOOLBOX 22

Item# 17187311

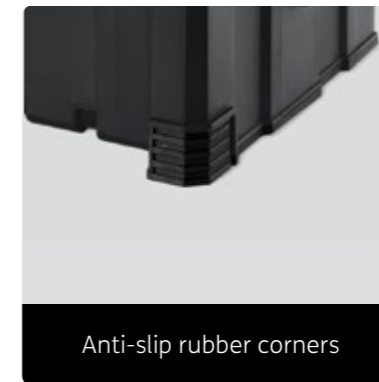
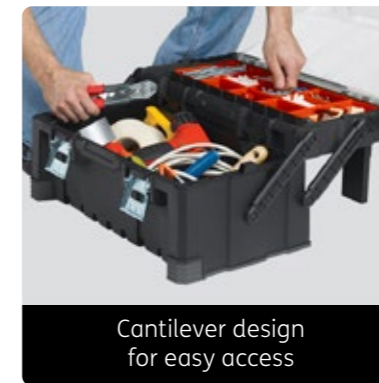
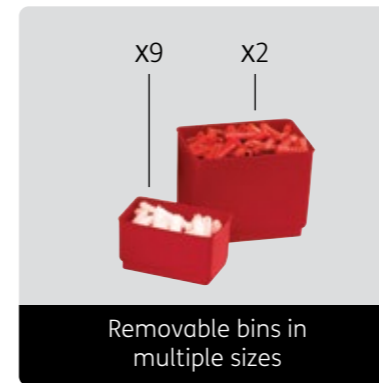

# CANTILEVERS AND ORGANIZERS

## CANTILEVER ORGANIZER 18

Item# 17186819

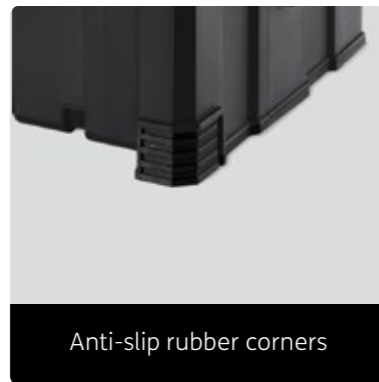
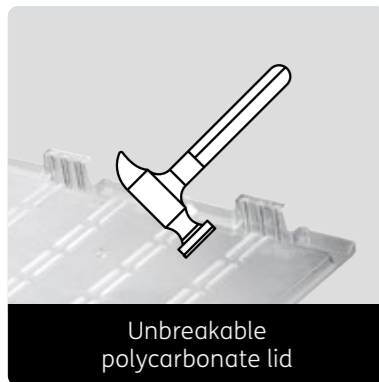
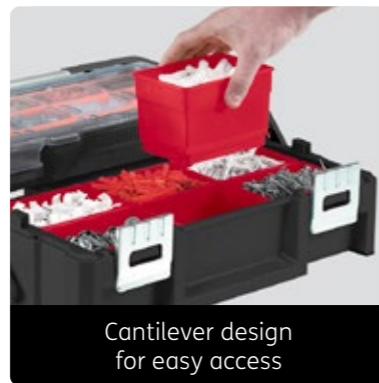
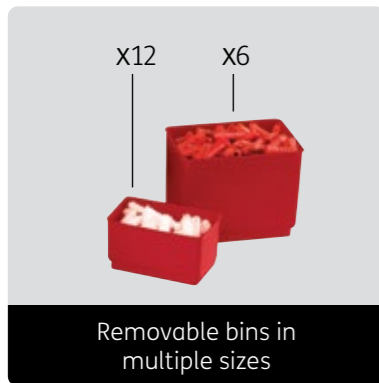

## CANTILEVER TRIO ORGANIZER

Item# 17198033

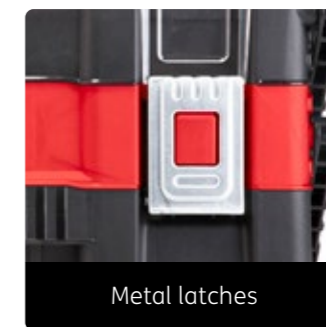
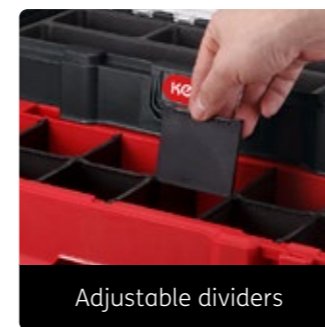





# 06

## MOBILE STORAGE

### **Hauling solutions for a wide range of jobs.**

Transport small and medium-sized tools to and from any job with ease in these incredibly practical systems, while high-impact construction keeps tools out of harm's way. The heavy-duty design protects your tools on the job site and in transit, while sturdy metal hinges and latches offer reliable performance – year after year.

# MOBILE STORAGE

## MASTER LOADER - SLIDING TOOL CHEST

Item# 17191709

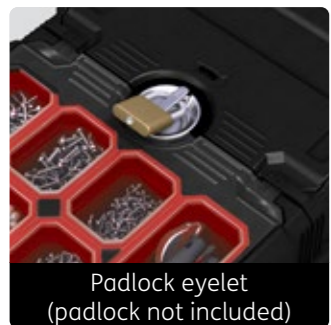

Padlock eyelet  
(padlock not included)



Handle with soft grip



6 removable bins  
in two sizes



Durable rubber wheels

## 25" HAWK CART + 22" TOOLBOX

Item# 17181110

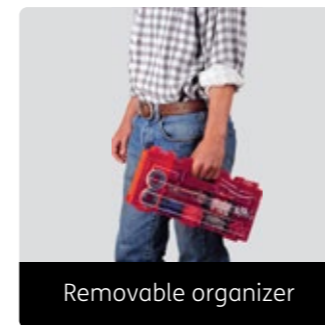

Removable organizer



Removable tool tray

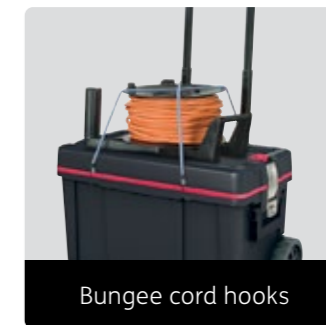

Bungee cord hooks

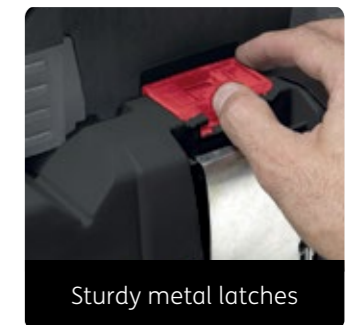

Sturdy metal latches

# MOBILE STORAGE

## CANTILEVER JOB BOX

Item# 17203037

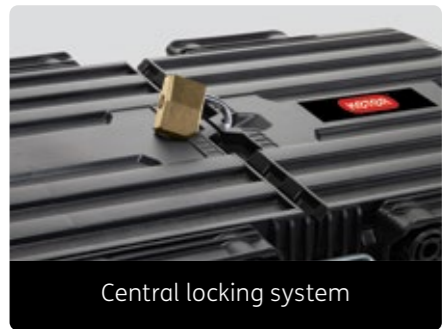

Central locking system

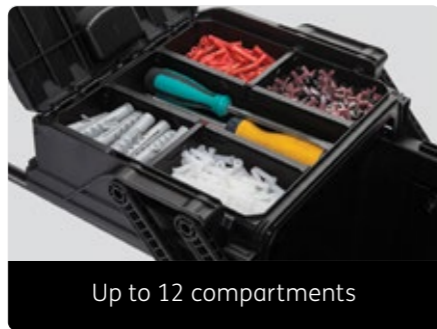

Up to 12 compartments



Heavy-duty metal handle with soft grip



Integrated water seal



Durable rubber wheels



Durable metal latches





# 07

## TOOLBOXES

**Heavy-duty toolboxes that are great in every situation.** Perfect for pros and serious DIY enthusiasts. Strong, compact and extremely practical, these toolboxes are the perfect home for your medium-sized tools and small parts.



# TOOLBOXES

## HAWK - TOOLBOX 22

Item# 17181009

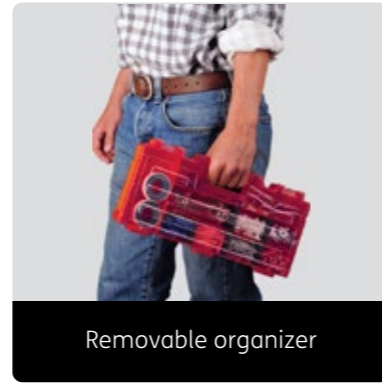

Removable organizer

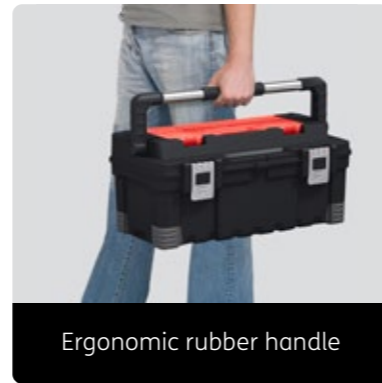

Ergonomic rubber handle

## HAWK - TOOLBOX 26

Item# 17181010



Non-slip rubber corners

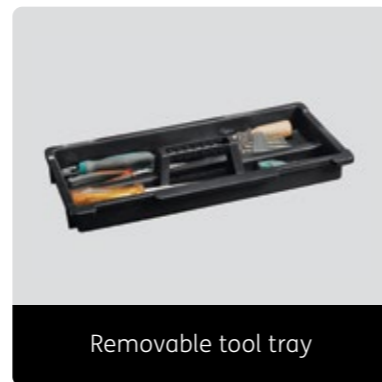

Removable tool tray

## TECHNICIAN CASE

Item# 17198036



Metal stopper to support lid



Durable metal latches



Carrying handle



Customizable dividers for smart use



Reinforced metal ring for shoulder strap

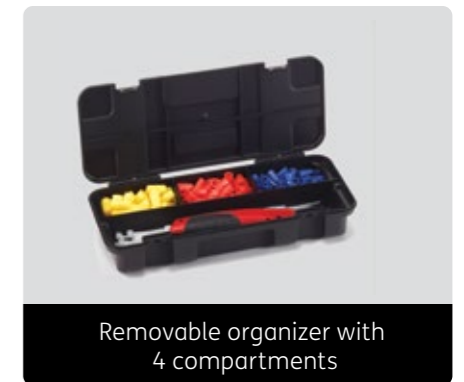

Removable organizer with 4 compartments

# TOOLBOXES

## WIDE TOOLBOX 16

Item# 17191708



## 19" TOOLBOX ML

Item# 17209269



## HERO BOX 13 + HERO BOX 16

Item# 17193992

## 16" TOOLBOX ML

Item# 17209268

## 22" TOOLBOX ML

Item# 17209270



Metal latches



Removable tray



2 integrated organizers





# 08

## WORKBENCHES AND SAWHORSES

**Multi-functional workbenches and sawhorses that work the way you do.** Designed with professionals in mind, these ultra-strong, ultra-portable workbenches and sawhorses set up fast and let you work effectively on multi-level surfaces. They also have a unique folding system that makes them especially simple to set up and pack away.

# WORKBENCHES AND SAWHORSES

## JOBMADE WITH RAILS

Item# 17202215



## ULTIMATE JOBMADE

Item# 17213752

**COMING SOON**



**453** | **1000**  
Kg | Lb

Max weight  
453 kg / 1000 lb

Easy setup

Folds for compact storage and portability

**453** | **1000**  
Kg | Lb

Max weight  
453 kg / 1000 lb

Easy setup

Folds for compact storage and portability

Built-in stabilizer

Includes removable small parts organizer

Includes 4 miniclamps

Anti-slip rubber leg pads

User-friendly security mechanism

Dog holes for versatile clamping compatibility (accessories not included)

# WORKBENCHES AND SAWHORSES

## FOLDING WORK TABLE



Compact and lightweight



Max weight  
453 kg / 1000 lb



Carrying handle

### EASY 30-SECOND ASSEMBLY

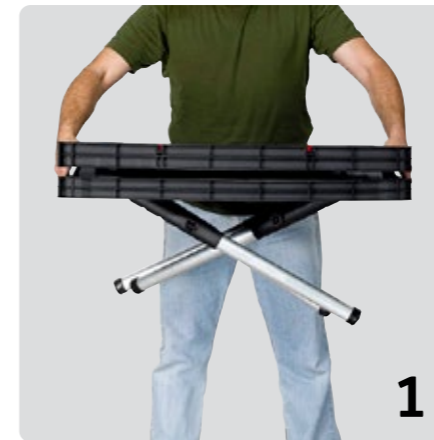

1

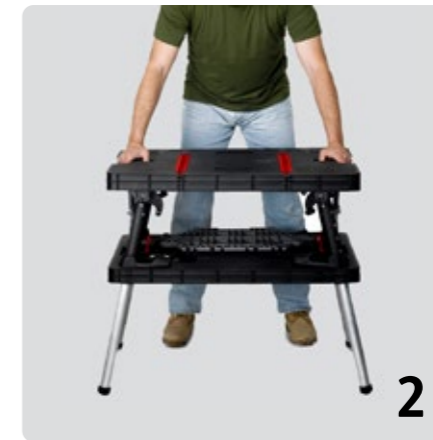

2



3

### FOLDING WORK TABLE WITH 12" CLAMPS

Item# 17182239

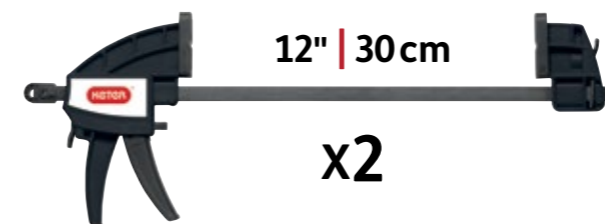

12" | 30 cm

x2

### FOLDING WORK TABLE WITH MINIC LAMPS

Item# 17210295



x2

### SAWHORSE 23







Item# 17182236





# PRODUCT INDEX

**PRO GEAR SYSTEM**









PRODUCT	NAME AND ITEM #	PRODUCT DIM. (WxDxH)	PRODUCT VOL.	MASTER PACK QTY	PALLET			MADE IN	
		PACKAGE DIM. (WxDxH)			SLIPSHEET				
					20FT CONTAINER	40FT CONTAINER	40HC CONTAINER		
	<b>PRO GEAR SYSTEM 2.0</b>	64.8 x 47.8 x 87.2 cm 25.5" x 18.8" x 34.3"	111 L	1	8/64	8/144	10/180	IL	
	17212618	65.8 x 48.3 x 88.8 cm 25.9" x 19" x 35"	29.3 Gal		8/80	8/168	10/210		
	<b>PRO GEAR CART 2.0</b>	64.8 x 47.8 x 78.9 cm 25.5" x 18.8" x 31"	57.5 L	2	16/128	16/288	20/360	IL	
	17211897	66 x 55 x 84.2 cm 26" x 21.6" x 33.1"	15.2 Gal		20/160	20/360	24/432		
	<b>PRO GEAR TOOLBOX 2.0</b>	57.1 x 35.6 x 31.6 cm 22.5" x 14" x 12.4"	37.4L	2	42/336	42/756	50/900	IL	
	17211898	57.7 x 36 x 62.5 cm 22.7" x 14.2" x 24.6"	9.8 Gal		50/400	50/900	56/1008		
	<b>PRO GEAR PTC 2.0</b>	57.1 x 35.1 x 16.7 cm 22.5" x 14" x 6.6"	16.1 L	3	84/672	84/1512	96/1728	IL	
	17211899	57.7 x 35.8 x 49.5 cm 22.7" x 14.1" x 19.5"	4.2 Gal		84/672	84/1512	105/1890		
	<b>PRO GEAR HALF ORG GEN 2.0</b>	34.8 x 26.8 x 9.5 cm 13.7" x 10.5" x 3.7"	4.3 L	4	168/2520	168/5208	192/6144	IL	
	17211900	36.8 x 37.7 x 28.2 cm 14.5" x 14.8" x 11.1"	1.1 Gal		252/2520	252/5040	324/6480		
	<b>PRO GEAR XL TOOLBOX 2.0</b>	56.6 x 37.5 x 41.3 cm 22.3" x 14.8" x 16.25"	57.5 L	2	28 / 224	28/504	30/540	IL	
	17211901	57.1 x 38.5 x 83.2 cm 22.5" x 15.25" x 32.8"	15.2 Gal		28/224	28/504	36/720		
	<b>PRO GEAR CLEAR ORGANIZER 22</b>	56 x 34.5 x 12.8 cm 22" x 13.6" x 5"	14 L	4	80/800	80/1680	96/2016	IL	
	17206659	58 x 53 x 36 cm 22.8" x 20.9" x 14.2"	7.92 Gal		96/960	96/2016	112/2352		
	<b>PRO GEAR CRATE 22"</b>	56 x 32 x 25 cm 22" x 12.6" x 9.8"	44 L	5	30/300	30/720	60/1440	IL	
	17202245	57 x 33 x 122 cm 22.4" x 13" x 48"	11.6 Gal		40/320	40/720	80/2304		

**PRO GEAR SYSTEM**

PRODUCT	NAME AND ITEM #	PRODUCT DIM. (WxDxH)	PRODUCT VOL.	MASTER PACK QTY	PALLET			MADE IN	
		PACKAGE DIM. (WxDxH)			SLIPSHEET				
					20FT CONTAINER	40FT CONTAINER	40HC CONTAINER		
	<b>PRO GEAR 28" JOB BOX</b>	72.4 x 35 x 31.6 cm 28.5" x 13.8" x 12.4"	45L	2	18/288	18/576	20/640	IL	
	17210204	73.4 x 35.6 x 64.4 cm 28.9" x 14" x 25.4"	11.9 Gal		18/288	18/594	20/660		
	<b>PRO GEAR XL 3 DRAWERS</b>	56.6 x 38.5 x 41.3 cm 22.3" x 15.2" x 16.3"	26.4L	1	18/252	18/540	20/600	IL	
	17212468	57.5 x 39.5 x 42.6 cm 22.6" x 15.6" x 16.8"	6.9 Gal		30/300	30/600	36/720		
	<b>PRO GEAR XL 2 DRAWERS</b>	56.6 x 38.5 x 41.3 cm 22.3" x 15.2" x 16.3"	28 L	1	18/252	18/540	20/600	IL	
	17212781	57.5 x 39.5 x 42.6 cm 22.6" x 15.6" x 16.8"	7.4 Gal		30/300	30/600	36/720		
	<b>XL 3 DRAWERS CART</b>	64.8 x 47.8 x 78.9 cm 25.5" x 18.8" x 31.1"	26.4L	2	10/120	23/276	46/368	IL	
	17212783	83.8 x 66.1 x 54.7 cm 33" x 26.02" x 21.5"	6.9 Gal		22/176	23/368	46/368		
	<b>XL 2 DRAWERS CART</b>	64.8 x 47.8 x 78.9 cm 25.5" x 18.8" x 31.1"	28 L	2	10/120	23/276	46/368	IL	
	17212784	83.8 x 66.1 x 54.7 cm 33" x 26.02" x 21.5"	7.4 Gal		22/176	23/368	46/368		
	<b>LUMBERJACK SAWHORSE</b>	71 x 69 x 82 cm 28" x 27.2" x 32.3"	-	4	28/476	28/476	32/1152	IL	
	17203039	72.5 x 32 x 84 cm 28.5" x 12.6" x 33.1"	-		36/468	36/1008	48/1344		
	<b>HYBRID PORTABLE WORKBENCH</b>	<b>Folded</b> 88 x 55.4 x 11.2 cm 34.6" x 21.8" x 4.4"		1	38/456	38/988	40/1040	IL	
	17213476	<b>Open</b> 98 x 65 x 81.3 cm 38.6" x 25.6" x 32"			38/456	38/988	44/1144		











## CONNECT SYSTEM

PRODUCT	NAME AND ITEM #	PRODUCT DIM. (WxDxH)	PRODUCT VOL.	MASTER PACK QTY	PALLET			MADE IN	
		PACKAGE DIM. (WxDxH)			SLIPSHEET				
					20FT CONTAINER	40FT CONTAINER	40HC CONTAINER		
	<b>CONNECT ROLLING SYSTEM</b> 17203038	56.5 x 37.3 x 70 cm 22.2" x 14.7" x 27.6"	88.4 L	1	10/150	10/310	12/372	IL	
		57.5 x 38.3 x 71.5 cm 22.6" x 15.1" x 28.1"	23.3 Gal		12/180	12/372	14/434		
	<b>CONNECT CANTI ORGANIZER</b> 17203103	56.5 x 31.7 x 16.1 cm 22.2" x 12.5" x 6.3"	14 L	4	112/768	96/1728	112/2016	IL	
		57.5 x 32.7 x 63.5 cm 22.6" x 12.9" x 25"	3.7 Gal		112/896	156/2808	128/2304		
	<b>CONNECT SYS 2 DRAWERS</b> 17208564	54.2 x 31 x 18.5 cm 21.3" x 12.2" x 7.3"	10.5 L	4	80/640	80/1440	96/1728	IL	
		62.8 x 56.6 x 36.7 cm 24.7" x 22.3" x 14.4"	2.8 Gal		96/864	96/1824	112/2128		
	<b>CONNECT ORGANIZER</b> 17205287	55.8 x 30.2 x 11.4 cm 22" x 11.9" x 4.5"	12.6 L	6	144/1152	144/2592	168/3024	IL	
		56.8 x 31.2 x 62.5 cm 22.4" x 12.3" x 24.6"	3.3 Gal		156/1248	156/2808	192/3456		
	<b>CONNECT CADDY</b> 17206124	54.2 x 30 x 13.9 cm 21.3" x 11.8" x 5.5"	12.5 L	4	128/1024	128/2304	144/2592	IL	
		57 x 31 x 52.3 cm 22.4" x 12.2" x 20.6"	3.3 Gal		128/1024	128/2304	144/2592		
	<b>CONNECT CANTI TOOL BOX</b> 17203104	56.5 x 31.7 x 25.1 cm 22.2" x 12.5" x 9.9"	26 L	2	64/512	64/1152	72/1296	IL	
		57.5 x 32.7 x 50.5 cm 22.6" x 12.9" x 19.9"	6.9 Gal		64/512	64/1152	80/1440		
	<b>CONNECT TOOL BOX</b> 17205288	55.8 x 31.2 x 27.5 cm 22" x 12.3" x 10.8"	29.6 L	2	40/400	40/960	48/1152	IL	
		56.8 x 32 x 54.5 cm 22.4" x 12.6" x 21.5"	7.8 Gal		48/576	48/1152	52/1248		
	<b>CONNECT CART+ORG</b> 17205661	56.5 x 37.3 x 55 cm 22.2" x 14.7" x 21.7"	58.8 L	1	12/180	14/434	16/496	IL	
		57.5 x 38.3 x 57 cm 22.6" x 15.1" x 22.4"	15.5 Gal		18/180	18/360	24/480		



## CONNECT SYSTEM

PRODUCT	NAME AND ITEM #	PRODUCT DIM. (WxDxH)	PRODUCT VOL.	MASTER PACK QTY	PALLET			MADE IN	
		PACKAGE DIM. (WxDxH)			SLIPSHEET				
					20FT CONTAINER	40FT CONTAINER	40HC CONTAINER		
	<b>CONNECT TROLLEY CART</b> 17205514	55.6 x 43.7 x 16.4 cm 21.9" x 17.2" x 6.5"	-	4	48/576	48/1248	56/1456	IL	
		57 x 45.5 x 60 cm 22.4" x 17.9" x 23.6"	-		48/576	48/1248	64/1664		





## STACK N ROLL SYSTEM

PRODUCT	NAME AND ITEM #	PRODUCT DIM. (WxDxH)	PRODUCT VOL.	MASTER PACK QTY	PALLET			MADE IN	
		PACKAGE DIM. (WxDxH)			SLIPSHEET				
					20FT CONTAINER	40FT CONTAINER	40HC CONTAINER		
	<b>STACK N ROLL SYSTEM</b> 17210365	52.5 x 41.1 x 69.4 cm 20.7" x 16.2" x 27.3"	84.2 L	1	15/120	15/240	18/324	IL	
		53 x 42.5 x 71 cm 20.9" x 16.7" x 28"	22.2 Gal		18/144	18/324	20/360		
	<b>STACK N ROLL TOOLBOX</b> 17210774	52.5 x 34.5 x 26 cm 20.7" x 13.6" x 10.2"	29.4 L	2	48/480	48/1056	48/1056	IL	
		53.1 x 35.2 x 52 cm 20.9" x 13.9" x 20.5"	7.7 Gal		48/480	48/1056	56/1232		
	<b>STACK N ROLL ORGANIZER</b> 17210772	51.5 x 34.5 x 11.5 cm 20.3" x 13.6" x 4.5"	9.8 L	3	108/1080	108/2376	126/2772	IL	
		52 x 35.2 x 23 cm 20.5" x 13.9" x 9.1"	2.6 Gal		126/1260	126/2520	147/2940		
	<b>STACK N ROLL CART</b> 17210777	52.5 x 41.1 x 56.8 cm 20.7" x 16.2" x 22.4"	45 L	2	20/200	20/480	24/576	IL	
		53.1 x 42.2 x 72 cm 20.9" x 16.6" x 28.3"	11.9 Gal		24/288	24/600	24/600		
	<b>STACK N ROLL 2 DRAWER UNIT</b> 17210832	48.1 x 33.2 x 23.3 cm 18.9" x 13.1" x 9.2"	6 L	2	56/560	56/1176	70/1470	IL	
		49.2 x 34.2 x 47.2 cm 19.4" x 13.5" x 18.6"	1.6 Gal		108/864	108/1944	126/2268		
	<b>STACK N ROLL 3 ORGANIZER SET</b> 17210831	48.1 x 33.2 x 23.3 cm 18.9" x 13.1" x 9.2"	3.6 L	2	56/560	56/1176	70/1470	IL	
		49.2 x 34.2 x 47.2 cm 19.4" x 13.5" x 18.6"	0.9 Gal		54/540	54/1134	66/1386		
	<b>STACK N ROLL POWER TOOL CASE + ORG</b> 17211432	52.6 x 34.1 x 14.8 cm 20.7" x 13.4" x 5.8"	14 L	3	84/840	84/1848	90/1980	IL	
		53.4 x 35.3 x 43.5 cm 21" x 13.9" x 17.1"	3.7 Gal		108/864	108/1944	126/2268		
	<b>STACK N ROLL HALF ORGANIZER</b> 17211433	38.8 x 24.2 x 7.8 cm 15.3" x 9.5" x 3.1"	2.4 L	6	360/3600	360/7560	396/8316	IL	
		41.2 x 25.5 x 41.5 cm 16.2" x 10" x 16.3"	0.6 Gal		360/3600	360/7560	432/9072		







## STACK N ROLL SYSTEM

PRODUCT	NAME AND ITEM #	PRODUCT DIM. (WxDxH)	PRODUCT VOL.	MASTER PACK QTY	PALLET			MADE IN	
		PACKAGE DIM. (WxDxH)			SLIPSHEET				
					20FT CONTAINER	40FT CONTAINER	40HC CONTAINER		
	<b>STACK N ROLL SYS W/PTC</b> 17211896	52.5 x 41.1 x 74 cm 20.7" x 16.2" x 29.1"	88.4 L	1	15/120	15/270	18/324	IL	
		53.5 x 42.4 x 75.2 cm 21.1" x 16.7" x 29.6"	23.3 Gal		15/120	15/270	18/324		
	<b>STACK N ROLL CLEAR ORGANIZER</b> 17212328	39.3 x 30.7 x 4.8 cm 15.5" x 12.1" x 1.9"	9.8 L	8	30/2400	30/5040	36/6048	IL	
		48.5 x 37.5 x 35.6 cm 19.1" x 14.8" x 14"	2.6 Gal		36/3456	36/6912	42/8064		







## DRAWER SYSTEM

PRODUCT	NAME AND ITEM #	PRODUCT DIM. (WxDxH)	PRODUCT VOL.	MASTER PACK QTY	PALLET			QTY ON TRUCK IN EUROPE	MADE IN
		PACKAGE DIM. (WxDxH)			20FT CONTAINER	40FT CONTAINER	40HC CONTAINER		
	<b>2 DRAWER TOOL CHEST</b> 17199303	28.9 x 56.2 x 26.2 cm 11.4" x 22.1" x 10.3"	17.1 L	2	TBA/264	TBA/600	TBA/792	792	EUR
		30 x 57.2 x 52.2 cm 11.8" x 22.5" x 20.5"	4.5 Gal		TBA/352	TBA/800	TBA/800		
	<b>3 DRAWER TOOL CHEST</b> 17199302	28.9 x 56.2 x 26.2 cm 11.4" x 22.1" x 10.3"	17.1 L	2	TBA/264	TBA/600	TBA/792	792	EUR
		30 x 57.2 x 52.2 cm 11.8" x 22.5" x 20.5"	4.5 Gal		TBA/352	TBA/800	TBA/800		
	<b>5 DRAWER TOOL CHEST</b> 17199301	<b>With Wheels</b> 37.8 x 59.9 x 59.9 cm 14.9" x 23.6" x 23.6"	33.4 L	1	TBA/132	TBA/300	TBA/396	396	EUR
		<b>W/O Wheels</b> 28.9 x 56.2 x 50.2 cm 11.3" x 22.1" x 19.7"							
	<b>7 DRAWER TOOL CHEST</b> 17200395	<b>With Wheels</b> 37.8 x 59.8 x 59.8 cm 23.6" x x 23.6"	50.5 L	1	TBA/110	TBA/250	TBA/330	330	EUR
		<b>W/O Wheels</b> 28.9 x 56.2 x 74.2 cm 11.3" x 22.1" x 29.2"							
		30 x 57.2 x 75.4 cm 11.8" x 22.5" x 29.6"	13.3 Gal		TBA/154	TBA/350	TBA/400		



## CANTILEVERS AND ORGANIZERS

PRODUCT	NAME AND ITEM #	PRODUCT DIM. (WxDxH)	PRODUCT VOL.	MASTER PACK QTY	PALLET			QTY ON TRUCK IN EUROPE	MADE IN
		PACKAGE DIM. (WxDxH)			20FT CONTAINER	40FT CONTAINER	40HC CONTAINER		
	<b>CANTILEVER ORGANIZER 22</b> 17185073	57.2 x 30.7 x 16.7 cm 22.5" x 12.1" x 6.6"	14 L	3	48/624	48/1200	48/1200	1584	EUR
		58 x 32 x 51.5 cm 22.8" x 12.6" x 20.2"	3.7 Gal		-	-	-		
	<b>CANTILEVER TOOLBOX 22</b> 17187311	56.7 x 31.4 x 24.5 cm 22.3" x 12.3" x 9.6"	26 L	2	40/520	40/1000	40/1000	1320	EUR
		57.5 x 32.5 x 50 cm 22.6" x 12.8" x 19.7"	6.9 Gal		-	-	-		
	<b>CANTILEVER ORGANIZER 18</b> 17186819	45.8 x 24 x 14.5 cm 18" x 9.4" x 5.7"	5.8 L	4	80/1360	80/2880	96/3456	-	IL
		46.5 x 25 x 59.5 cm 18.3" x 9.8" x 23.4"	1.5 Gal		80/1440	80/2960	96/3552		
	<b>TRIO ORGANIZER</b> 17198033	53 x 20 x 23.3 cm 20.8" x 7.9" x 9.2"	5.8 L	4	-	-	-	2112	EUR
		55.3 x 40 x 46.1 cm 21.7" x 15.7" x 18.1"	1.5 Gal		-	-	-		
	<b>ORGANIZER 14</b> 17331644	23.5 x 36.5 x 5 cm 9.2" x 14.3" x 2"	3.3 L	12	3168	7200	9504	9504	EUR
		46.5 x 30.2 x 36.7 cm 18.3" x 12" x 14.5"	0.8 Gal		3696	8400	9600		
	<b>ORGANIZER 11</b> 17181118	19 x 27.5 x 4.2 cm 7.5" x 10.8" x 1.7"	3.3 L	10	6600	15000	19800	19600	EUR
		240 x 390 x 290 cm 94.3" x 153.3" x 114"	0.8 Gal		7700	17500	20000		

## TOOLBOXES

PRODUCT	NAME AND ITEM #	PRODUCT DIM. (WxDxH)	PRODUCT VOL.	MASTER PACK QTY	PALLET			QTY ON TRUCK IN EUROPE	MADE IN
		PACKAGE DIM. (WxDxH)			SLIPSHEET				
					20FT CONTAINER	40FT CONTAINER	40HC CONTAINER		
	<b>HAWK TOOLBOX 22</b>	56.5 x 29 x 24.08 cm 22.2" x 11.4" x 9.5"	24 L	2	TBA/560	TBA/1664	52/1716	1456	EUR
	17181009	56.5 x 29 x 49.6 cm 22.2" x 11.4" x 19.5"	6.3 Gal		48/528	48/960	48/960		
	<b>HAWK TOOLBOX 26</b>	66.7 x 27.7 x 27.1 cm 26.2" x 10.9" x 10.7"	35.6 L	2	TBA/308	TBA/800	32/1056	1056	EUR
	17181010	66.7 x 27.7 x 54.2 cm 26.2" x 108.9" x 21.3"	9.4 Gal		36/648	36/1056	36/1056		
	<b>TECHNICIAN CASE</b>	48 x 38 x 17.5 cm 18.9" x 14.9" x 6.9"	16.3 L	4	40/520	40/1000	40/1000	1320	EUR
	17198036	72 x 49 x 39.5 cm 28.3" x 19.3" x 15.5"	4.3 Gal		-	-	-		
	<b>WIDE TOOLBOX 16</b>	41.6 x 32.7 x 20.5 cm 16.3" x 12.9" x 8.1"	16 L	5	TBA/800	TBA/1260	70/2310	1920	EUR
	17191708	43 x 34 x 103.5 cm 16.9" x 13.4" x 40.7"	4.2 Gal		-	-	-		
	<b>HERO BOX 13</b>	33 x 20 x 16 cm 13" x 7.9" x 6.3"	10.6 L	2	120/1560	120/3000	120/3000	3960	EUR
	17193615	33 x 20 x 32 cm 13" x 7.9" x 12.6"	2.8 Gal		-	-	-		
	<b>HERO BOX 16</b>	39.5 x 23 x 22 cm 15.5" x 9" x 8.6"	19.8 L	2	80/1040	80/2000	80/2000	2640	EUR
	17193614	39.5 x 23 x 44 cm 15.5" x 9" x 17.3"	5.2 Gal		-	-	-		
	<b>HERO BOX 13+16</b>	39.6 x 23.1 x 22.1 cm 15.6" x 9.1" x 8.7"	19.8 L	2	80/1040	80/2000	80/2000	2640	EUR
	17193992	39.5 x 23 x 44.5 cm 15.5" x 9" x 17.5"	5.2 Gal		-	-	-		







## TOOLBOXES

PRODUCT	NAME AND ITEM #	PRODUCT DIM. (WxDxH)	PRODUCT VOL.	MASTER PACK QTY	PALLET			QTY ON TRUCK IN EUROPE	MADE IN
		PACKAGE DIM. (WxDxH)			SLIPSHEET				
					20FT CONTAINER	40FT CONTAINER	40HC CONTAINER		
	<b>16" TOOL BOX ML</b>	39.7 x 21.3 x 20.6 cm 15.6" x 8.47" x 8.1"	TBA	6	60/660	60/1500	60/1500	2376	EUR
	17209268	44.6 x 40.7 x 63.3 cm 17.5" x 16" x 24.9"	TBA		-	-	-		
	<b>19" TOOL BOX ML</b>	48 x 26 x 25 cm 18.9" x 10.2" x 9.8"	TBA	6	48/528	48/1200	48/1200	1584	EUR
	17209269	51 x 49 x 79.5 cm 20" x 19.3" x 31.2"	TBA		-	-	-		
	<b>22" TOOL BOX ML</b>	56 x 31 x 28.5 cm 22" x 12.2" x 11.2"	TBA	4	24/264	24/600	24/800	792	EUR
	17209270	63 x 57 x 58.5 cm 24.8" x 22.4" x 23"	TBA		-	-	-		

## MOBILE STORAGE

	<b>SLIDING TOOL CHEST 18G</b>	61.6 x 37.8 x 41.5 cm 24.3" x 14.9" x 16.3"	50 L	2	14/224	14/476	14/476	-	IL
	17191709	62.1 x 38.3 x 84 cm 24.5" x 15.08" x 33.07"	13.2 Gal		14/252	14/532	18/684		
	<b>25" HAWK CART + 22" TOOLBOX</b>	65.5 x 37.8 x 45.5 cm 25.7" x 14.9" x 17.9"	88 L	1	TBA/240	TBA/425	30/540	540	EUR
	17181110	65.5 x 37.8 x 45.5 cm 25.7" x 14.9" x 17.9"	23.2 Gal		-	17/612	17/612		
	<b>15G CANTILEVER JOB BOX</b>	64.6 x 37.3 x 41 cm 25.4" x 14.7" x 16.1"	57 L	2	TBA/198	TBA/500	20/640	660	EUR
	17203037	65.5 x 38.3 x 83.5 cm 25.7" x 15.1" x 32.8"	15.6 Gal		-	-	-		

## WORKBENCHES AND SAWHORSES



PRODUCT	NAME AND ITEM #	PRODUCT DIM. (WxDxH)	PRODUCT VOL.	MASTER PACK QTY	PALLET			QTY ON TRUCK IN EUROPE	MADE IN
		PACKAGE DIM. (WxDxH)			SLIPSHEET				
					20FT CONTAINER	40FT CONTAINER	40HC CONTAINER		
	<b>JOBMADE WITH RAILS</b> 17202215	<b>Folded</b> 88 x 55.4 x 11.2 cm 34.6" x 21.8" x 4.4" <b>Open</b> 98 x 65 x 81.3 cm 38.6" x 25.6" x 32"			38/456	38/988	40/1040		
	<b>HYBRID PORTABLE WORKBENCH</b> 17213476	88.5 x 56 x 11.5 cm 34.8" x 22.2" x 4.5"		1	38/456	38/988	44/1144		IL
	<b>ULTIMATE JOBMADE</b> 17213752								IL
	<b>FOLDING WORK TABLE WITH 12" CLAMPS</b> 17182239	<b>Folded</b> 85.6 x 55.5 x 11.2 cm 33.5" x 21.7" x 4.4" <b>Open</b> 91 x 55 x 75.5 cm 35.8" x 21.6" x 29.7"			34/408	34/884	40/1040		
	<b>FOLDING WORK TABLE WITH MINICLAMPS</b> 17210295	85.6 x 56.5 x 12 cm 33.4" x 22" x 4.5"		1	38/494	38/1026	22/1188		IL
	<b>LUMBERJACK SAWHORSE</b> 17203039	71 x 69 x 82 cm 28" x 27.2" x 32.3" 72.5 x 32 x 84 cm 28.5" x 12.6" x 33.1"		4	28/476	28/476	32/1152		IL
	<b>SAWHORSE 23</b> 17182236	57.8 x 10.2 x 79.2 cm 22.7" x 4" x 31.1" 80 x 58 x 31 cm 31.4" x 22.8" x 12.2"		3	36/468	36/900	36/900	1188	EUR

# E-COMMERCE INDEX

PRODUCT	NAME AND ITEM #	PRODUCT DIM. (WxDxH)	PRODUCT VOL.	MASTER PACK QTY	PALLET
		PACKAGE DIM. (WxDxH)			SLIPSHEET

40HC CONTAINER



## PRO GEAR SYSTEM

	<b>PRO GEAR CRATE</b>	56 x 32 x 25 cm 22" x 12.6" x 9.8"	33.8 L	1	48/1056
	17202245	57.5 x 34 x 28.2 cm 22.6" x 13.4" x 11.1"	8.9 Gal		54/1188
	<b>PRO GEAR ORGANIZER</b>	56 x 34.5 x 12.8 cm 22" x 13.6" x 5"	13.1 L	1	96/1920
	17206659	58 x 36 x 15 cm 22.8" x 14.2" x 5.9"	3.4 Gal		96/2016

## DRAWER SYSTEM

	<b>5 DRAWER TOOL CHEST</b>	<b>With wheels</b> 59.85 x 37.76 x 59.85 cm 23.56" x 14.86" x 23.56"	33.4 L	1	24/504
		<b>Without wheels</b> 56.2 x 28.9 x 50.2 cm 22.1" x 11.3" x 19.76"			
	17199301	60.3 x 32.5 x 55.3 cm 23.7" x 12.8" x 21.8"	8.8 Gal		24/528



## TOOLBOXES

	<b>TECHNICIAN CASE</b>	48 x 38 x 17.5 cm 18.9" x 15" x 6.9"	16.3 L	1	78/1638
	17198036	49.5 x 19 x 41 cm 19.5" x 7.5" x 16.2"	4.3 Gal		78/1638
	<b>HAWK - TOOLBOX 26</b>	66 x 28.7 x 26.6 cm 26" x 11.3" x 10.5"	35.6 L	1	48/1008
	17181010	67.5 x 30.2 x 29.6 cm 26.6" x 11.9" x 11.6"	9.4 Gal		48/1008



PRODUCT	NAME AND ITEM #	PRODUCT DIM. (WxDxH)	PRODUCT VOL.	MASTER PACK QTY	PALLET
		PACKAGE DIM. (WxDxH)			SLIPSHEET

40HC CONTAINER





## CANTILEVERS

	<b>CANTILEVER ORGANIZER 22</b>	57.2 x 30.7 x 16.7 cm 22.5" x 12.1" x 6.6"	14 L	1	78/1638
	17185073	58.5 x 33.5 x 20 cm 23" x 13.2" x 7.9"	3.7 Gal		78/1638
	<b>CANTILEVER TOOLBOX 22</b>	56.7 x 31.4 x 24.5 cm 22.3" x 12.4" x 9.6"	26 L	1	60/1260
	17187311	59 x 32 x 25 cm 23.2" x 12.6" x 9.8"	6.9 Gal		60/1260

## MOBILE STORAGE

	<b>15G CANTILEVER JOB BOX</b>	56.4 x 46.5 x 48 cm 22.2" x 18.3" x 18.9"	56 L	1	15/450
	17203037	66 x 38.8 x 44 cm 26" x 15.3" x 17.3"	14.8 Gal		20/480
	<b>SLIDING TOOL CHEST 18G</b>	61.6 x 37.8 x 41.5 cm 24.3" x 14.9" x 16.3"	65.3 L	1	24/528
	17191709	62.3 x 39.7 x 44.5 cm 24.5" x 15.6" x 17.5"	17.2 Gal		24/528

## WORKBENCHES AND SAWHORSES

PRODUCT	NAME AND ITEM #	PRODUCT DIM. (WxDxH)	PRODUCT VOL.	MASTER PACK QTY	PALLET
		PACKAGE DIM. (WxDxH)			SLIPSHEET
<b>40HC CONTAINER</b>					
	<b>HYBRID PORTABLE WORKBENCH</b>  17213476	<b>Folded</b> 88 x 55.4 x 11.2 cm 34.6" x 21.8" x 4.4"	N/A	1	36/864
		<b>Open</b> 97 x 64.5 x 81 cm 38.2" x 25.4" x 31.9"			
	<b>JOBMADE WITH RAILS</b>  17202215	92 x 57 x 12.7 cm 36.2" x 22.4" x 5"	N/A	1	40/960
	<b>FOLDING WORK TABLE</b>  17182239	<b>Folded</b> 88 x 55 x 11.2 cm 33.5" x 21.7" x 4.4"	N/A	1	28/616
		<b>Open</b> 85 x 55 x 75.5 cm 33.5" x 21.7" x 29.7"			
	<b>LUMBERJACK ADJUSTABLE LEGS WOOD TOP SAWHORSE</b>  17210240	<b>Folded</b> 71 x 6.9 x 82 cm 28" x 2.7" x 32.3"	N/A	2	19/494
		<b>Open</b> 71 x 42.2-55.6 x 77.47-98.7 cm 28" x 16.6-21.8" x 31"-38.9"			
		75 x 18 x 86.4 cm 29.5" x 7.09" x 30.02"			19/494

COMING SOON

## CONTACT US

### Keter Plastic Ltd. | TOOL STORAGE

1 Sapir St., Industrial Area, Herzliya 4685206, Israel  
Tel: +972-73-3280290 | Fax: +972-9-9554990

#### NORTH AMERICA

**Keter North America**  
6435 South Scatterfield Road  
Anderson, IN 46001, USA  
Tel: +1(888)-638-7056  
Fax: +1(765)-298-6832

**Accent Home Product Ltd.**  
5151 Thimens Blvd.  
H4R 2C8, Montreal, Quebec,  
Canada  
Tel: +1-800-661-6721  
Fax: +1(514)-748-7793

#### EUROPE

**Keter UK Ltd.**  
Cardrew Industrial Estate  
Cardrew Way, Redruth  
Cornwall, TR15 1ST, UK  
Tel: 44 01209 203 340  
Fax: 44 01209 313959

**Keter Iberia S.L.U.**  
Ctra. Logroño Km 4,5  
50011 Zaragoza, Spain  
Tel: +34 976 460 006  
Fax: +34 976 460 281

**Keter Benelux BV**  
Ericssonstraat 17  
5121 MK Rijen  
Postbus 224, 5120 AC Rijen  
The Netherlands  
Tel: +31 (0)161-228 900

**Keter Italy S.p.A.**  
Via Ing. G. Taliercio 2  
31024 Ormelle (TV), Italy  
Tel: +39 0422 745900  
Fax: +39 0422 745929

#### Keter France Sas

22 Avenue des Nations -  
Batiment Le Rabelais -  
Entrée C - 1er étage  
93420 Villepinte, France  
Tel: +33 (0)1 49 38 66 00  
Fax: +33 (0)1 49 38 66 19

#### Keter Poland Sp. z o.o.

Ul. Wroclawska 34  
76-200 Słupsk, Poland  
Tel: +48 (0)59 8411230  
Fax: +48 (0)59 8424214

#### Keter Hungary Kft.

Zsong Völgy 2.  
4211 Ebes, Hungary  
Tel: +36 (0)52 565 900  
Fax: +36 (0)52 565 990

#### Keter Germany GmbH

Steingrubenweg 11  
91639 Wolframs-Eschenbach,  
Deutschland  
Tel: +49 9875 97809-0  
Fax: +49 9875 97809-60

#### Keter Greece

P. Kostopoulos Sons s.a.  
1-3 Thesalonikis Street  
183 46 Moshato, Greece  
Tel: +30 210 4839700  
p-kostopoulos@kostopoulos.com

#### KETER AUSTRALIA

Tel: 1 300 449 107  
ronen.mazor@keter.com

#### SOUTH AFRICA

**First Dutch Brands**  
Tel: +27 2543 717 31  
sam@firstdutchbrands.co.za

#### SOUTH AMERICA

**International Home**  
Tel: +54-11-4582-0777  
Fax: + 54-11-4582-0188  
sofman@keterlatam.com

**Keter Mexico**  
Mi Mercadeo  
Tel: (55) 55849832  
humberto.rivera@keter.com

#### KETER KOREA

Tel: 82-31-767-2492  
william@keter.co.kr

#### KETER JAPAN

theSOHO 1314  
Aomi, Kouto-ku 2-7-4  
Tokyo 135-0064, Japan  
Tel: +81-3-6426-0711  
Gal.vered@keter.com



[www.keter.com](http://www.keter.com)