

INSTALLATION DEVICES

CATALOGUE OF INSTALLATION DEVICES AND ACCESSORIES

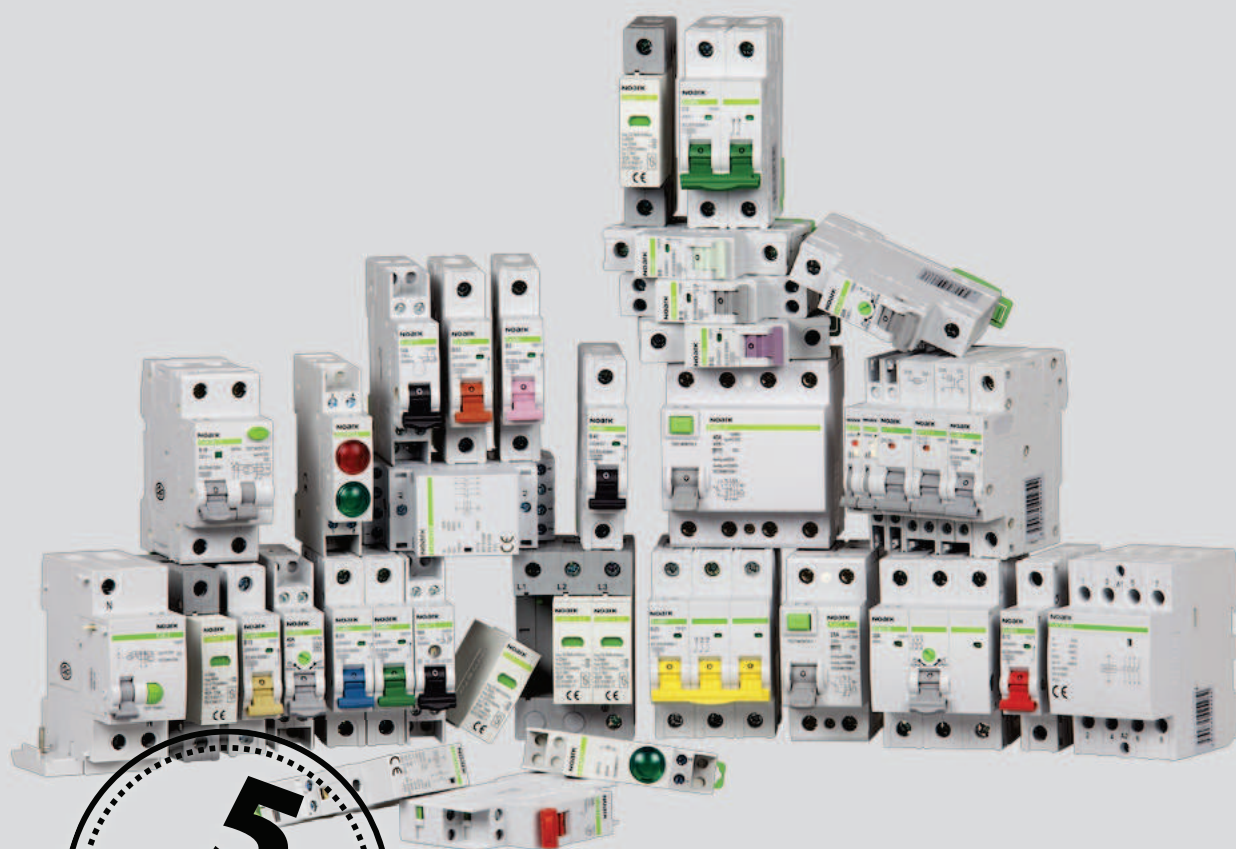

Valid from 1st May 2013

NOARK

New opportunity for you

Catalogues and assortment overview



INSTALLATION DEVICES

- Miniature Circuit Breakers
- Residual Current Devices
- Isolators
- Surge Protection Devices
- Other Installation Devices



MOULDED CASE CIRCUIT BREAKERS

- Moulded Case Circuit Breakers
- Moulded Case Switch Disconnectors



CONTACTORS AND OVERLOAD RELAYS

- Industrial Contactors
- Overload Relays



PLASTIC CONSUMER UNITS AND BUSBARS

- Consumer Units
- Interconnection Busbars



PHOTOVOLTAIC COMPONENTS AND SOLUTIONS

- Miniature Circuit Breakers
- Fuse Disconnectors
- Isolators
- Surge Protection Devices
- Moulded Case Circuit Breakers and Switch Disconnectors
- DC boards and Combiner Boxes

Content

Ordering information

Miniature Circuit Breakers

Ex9BH MCBs up to 63 A, 10 kA	7
Ex9BN MCBs up to 63 A, 6 kA	15
Ex9B125 MCBs up to 125 A	23
Ex9PN 1P+N MCBs in one-module, 6 kA	29
Ex9BD DC MCBs up to 63 A	33

Isolators

Ex9I125 Isolators up to 125 A	37
Ex9I40 Isolators up to 40 A in one-module	39
Ex9BI Isolators with accessories	41

Residual Current Devices

Ex9CL-H RCCBs up to 63 A, 10 kA	45
Ex9CL-100 RCCBs up to 100 A, 10 kA	45
Ex9CL-N RCCBs up to 63 A, 6 kA	51
Ex9CBL-H RCBOs up to 40 A, 10 kA	53
Ex9CBL-N RCBOs up to 40 A, 6 kA	59
Ex9LE RCD add-on blocks	65

Accessories for installation devices

Ex9B, Ex9PN accessories	71
Ex9CBL accessories	75

Surge Protection Devices

Ex9UE1+2 SPDs class I+II	77
Ex9UE2 SPDs class II	77

Other devices

Ex9CH20 Installation relays	81
Ex9CH Installation contactors	83
Ex9BT Change-over switches	85
Ex9PD Signal lamps	87
Ex9T Timers	91
Ex9SS Staircase switches	95
Ex9LA and Ex9LD Light intensity switches	97

Content

Technical information

Miniature Circuit Breakers	
Ex9BH MCBs up to 63 A, 10 kA	101
Ex9BN MCBs up to 63 A, 6 kA	104
Ex9B125 MCBs up to 125 A	107
Ex9PN 1P+N MCBs in one-module, 6 kA	111
Ex9BD DC MCBs up to 63 A	114
Isolators	
Ex9I125 Isolators up to 125 A	117
Ex9I40 Isolators up to 40 A in one-module	119
Ex9BI Isolators with accessories	121
Residual Current Devices	
Ex9CL-H RCCBs up to 63 A, 10 kA	123
Ex9CL-100 RCCBs up to 100 A, 10 kA	126
Ex9CL-N RCCBs up to 63 A, 6 kA	129
Ex9CBL-H RCBOs up to 40 A, 10 kA	132
Ex9CBL-N RCBOs up to 40 A, 6 kA	135
Ex9LE RCD add-on blocks	138
Accessories for installation devices	
Ex9B, Ex9PN accessories	141
Ex9CBL accessories	151
Surge Protection Devices	
Ex9UE1+2 SPDs class I+II	153
Ex9UE2 SPDs class II	154
Other devices	
Ex9CH20 Installation relays	159
Ex9CH Installation contactors	161
Ex9BT Change-over switches	163
Ex9PD Signal lamps	165
Ex9T Timers	167
Ex9SS Staircase switches	171
Ex9LA and Ex9LD Light intensity switches	173

NOARK Electric Introduction

NOARK Electric is a global electrical producer and forms a part of an international concern with more than 25 thousands of employees. Regional centers in Shanghai, Prague and Chicago drive business in each continent. Our mission is to bring a new opportunity and unrivalled customer care to the global low voltage market.

We are determined to go further into the world market and establish and maintain strong relationships with customers. NOARK Electric cares about different areas in a local way to meet the unique requirements of each market. For this reason, our worldwide business activities are coordinated locally in the individual areas.

NOARK Electric has invested millions of Euros in development and it is equipped with the most up-to-date technologies and production facilities. The intelligent low voltage distribution and control product lines with high quality, performance and stability were developed by our highly professional and skilled R&D team.

The first generation Ex9 series of intelligent low voltage electrical products, incorporating the latest design, electronic and simulation technologies, reach even the top industry expectations. This product series not only set multiple functions into ever smaller size, but includes also data acquisition, communications, and intelligent remote control modules, which reward NOARK Electric with up to tens of exclusive patents including invention, practical application and design. We firmly adhere to the concept of „best products are derived from best raw materials“, which is also the principle of our production. It is realized by cooperating with qualified suppliers with a very high selection standard. Besides complying with all compulsory domestic law requirements, full range of products is accredited by CB/CCA organizations based on up-to-date IEC and EN standards. NOARK Electric also takes care of local certifications to meet special requirements and habits of particular markets. Besides concentration on the product related technical issues, NOARK Electric cares about nature and closely follows the environmental policies.

Through global sales network, NOARK Electric has successfully contributed its efforts to provide high-efficient, high-reliable, high-intelligent and energy-saving low voltage products for reasonable prices to sophisticated industry areas, such as power distribution, smart grids, renewable energy, petrochemical industry, machinery manufacturing, real estate and construction.

We believe,

Remarkable technical innovations bring reliable products!

Advanced technical ideas create intelligent electrical apparatus for the future!

We are new opportunity for you!

NOARK Electric European team

NOARK Electric Introduction

Top-level technological facilities



General Information

NOARK products sales comply with the laws of the respective country and is regulated by general trading conditions, a framework agreement or by other contracts between NOARK Electric Europe s.r.o. or its subsidiary and the customer.

Goods price is defined by the respective valid official price list of the NOARK Electric Company and by the contractual conditions of the respective customer. If not negotiated otherwise, purchase price includes neither expenses for transport, transport wrapping, expenses connected with goods handling, with the installation and implementing into operation, nor expenses connected with disposal or recycling of the goods or the wrapping, if valid laws do not impose different obligation.

The NOARK Electric Company provides its products with a five-year European warranty. It may be applied outside the country where the product is bought. In this case it is submitted in a local subsidiary of NOARK Electric. Warranty conditions are described in detail in the NOARK Electric complaint procedure.



Miniature Circuit Breakers Ex9BH, 10 kA



- Miniature Circuit Breakers according to IEC / EN 60898-1
- Rated short circuit breaking capacity I_{cn} 10 kA
- 1 up to 4-pole versions
- Tripping characteristics B, C, D
- Rated current up to 63 A
- Rated operational voltage 230/400 V AC, 48 V DC (per pole)
- Wide range of accessories
- Toggle colour according to rated current I_n

Ex9BH miniature circuit breakers are suitable for domestic as well as industrial applications. They can be combined with wide range of accessories including auxiliary and signal contacts, shunt trip release, undervoltage and overvoltage release or RCD add-on block. It is possible to create diversified combination of accessories. These combinations are only limited by total number, not by the type of accessories - all components fit together. It can be used up to three units of auxiliary or alarm contacts plus up to two units for release units.

Type Key

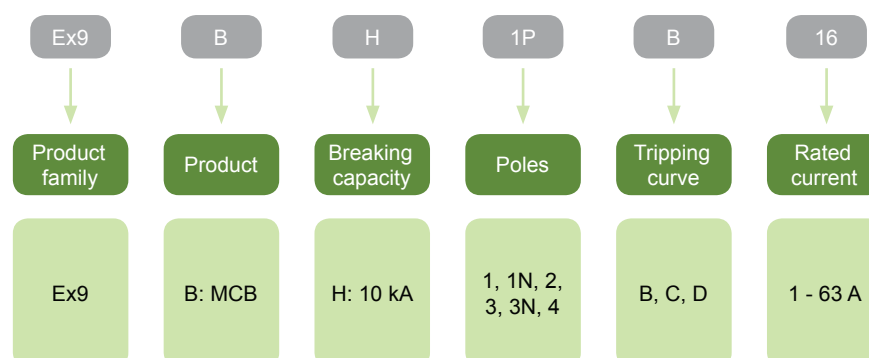

Certification marks



Miniature Circuit Breakers Ex9BH, 10 kA

Accessories



Auxiliary or signal contacts
AX, AL, AXL
Up to 3 units

Voltage or trip releases
SHT, UVT, OVT
Up to 2 units

MCB
Ex9B
1, 1+N, 2, 3, 3+N, 4-pole

RCD add-on block
Ex9LE
1+N, 2, 3, 3+N, 4-pole

Auxiliary contacts AX3111, AX3122

see page 72

Alarm contact AL3111

see page 72

Auxiliary and alarm contact AXL31

see page 72

Shunt trip releases SHT31, SHT3111

see page 72

Undervoltage releases UVT31, UVT3101, UVT3110

see page 73

Overtoltage release OVT31

see page 73

RCD add-on blocks Ex9LE

see page 65

RCD add-on blocks are mounted to the MCBs Ex9B from the right, the other accessories from the left and are identical for devices of the line Ex9B and Ex9PN.

Miniature Circuit Breakers Ex9BH, 10 kA

B-Characteristic, 1-pole



Rated current	Poles	Char.	Article No.	Type	Packing
1 A	1	B	100270	Ex9BH 1P B1	1/12/144
2 A	1	B	100271	Ex9BH 1P B2	1/12/144
3 A	1	B	100272	Ex9BH 1P B3	1/12/144
4 A	1	B	100273	Ex9BH 1P B4	1/12/144
6 A	1	B	100274	Ex9BH 1P B6	1/12/144
8 A	1	B	100275	Ex9BH 1P B8	1/12/144
10 A	1	B	100276	Ex9BH 1P B10	1/12/144
13 A	1	B	100277	Ex9BH 1P B13	1/12/144
16 A	1	B	100278	Ex9BH 1P B16	1/12/144
20 A	1	B	100279	Ex9BH 1P B20	1/12/144
25 A	1	B	100280	Ex9BH 1P B25	1/12/144
32 A	1	B	100281	Ex9BH 1P B32	1/12/144
40 A	1	B	100282	Ex9BH 1P B40	1/12/144
50 A	1	B	100283	Ex9BH 1P B50	1/12/144
63 A	1	B	100284	Ex9BH 1P B63	1/12/144

B-Characteristic, 1+N-pole



Rated current	Poles	Char.	Article No.	Type	Packing
1 A	1+N	B	100285	Ex9BH 1PN B1	1/6/72
2 A	1+N	B	100286	Ex9BH 1PN B2	1/6/72
3 A	1+N	B	100287	Ex9BH 1PN B3	1/6/72
4 A	1+N	B	100288	Ex9BH 1PN B4	1/6/72
6 A	1+N	B	100289	Ex9BH 1PN B6	1/6/72
8 A	1+N	B	100290	Ex9BH 1PN B8	1/6/72
10 A	1+N	B	100291	Ex9BH 1PN B10	1/6/72
13 A	1+N	B	100292	Ex9BH 1PN B13	1/6/72
16 A	1+N	B	100293	Ex9BH 1PN B16	1/6/72
20 A	1+N	B	100294	Ex9BH 1PN B20	1/6/72
25 A	1+N	B	100295	Ex9BH 1PN B25	1/6/72
32 A	1+N	B	100296	Ex9BH 1PN B32	1/6/72
40 A	1+N	B	100297	Ex9BH 1PN B40	1/6/72
50 A	1+N	B	100298	Ex9BH 1PN B50	1/6/72
63 A	1+N	B	100299	Ex9BH 1PN B63	1/6/72

B-Characteristic, 2-pole



Rated current	Poles	Char.	Article No.	Type	Packing
1 A	2	B	100300	Ex9BH 2P B1	1/6/72
2 A	2	B	100301	Ex9BH 2P B2	1/6/72
3 A	2	B	100302	Ex9BH 2P B3	1/6/72
4 A	2	B	100303	Ex9BH 2P B4	1/6/72
6 A	2	B	100304	Ex9BH 2P B6	1/6/72
8 A	2	B	100305	Ex9BH 2P B8	1/6/72
10 A	2	B	100306	Ex9BH 2P B10	1/6/72
13 A	2	B	100307	Ex9BH 2P B13	1/6/72
16 A	2	B	100308	Ex9BH 2P B16	1/6/72
20 A	2	B	100309	Ex9BH 2P B20	1/6/72
25 A	2	B	100310	Ex9BH 2P B25	1/6/72
32 A	2	B	100311	Ex9BH 2P B32	1/6/72
40 A	2	B	100312	Ex9BH 2P B40	1/6/72
50 A	2	B	100313	Ex9BH 2P B50	1/6/72
63 A	2	B	100314	Ex9BH 2P B63	1/6/72

Miniature Circuit Breakers Ex9BH, 10 kA

B-Characteristic, 3-pole



Rated current	Poles	Char.	Article No.	Type	Packing
1 A	3	B	100315	Ex9BH 3P B1	1/4/48
2 A	3	B	100316	Ex9BH 3P B2	1/4/48
3 A	3	B	100317	Ex9BH 3P B3	1/4/48
4 A	3	B	100318	Ex9BH 3P B4	1/4/48
6 A	3	B	100319	Ex9BH 3P B6	1/4/48
8 A	3	B	100320	Ex9BH 3P B8	1/4/48
10 A	3	B	100321	Ex9BH 3P B10	1/4/48
13 A	3	B	100322	Ex9BH 3P B13	1/4/48
16 A	3	B	100323	Ex9BH 3P B16	1/4/48
20 A	3	B	100324	Ex9BH 3P B20	1/4/48
25 A	3	B	100325	Ex9BH 3P B25	1/4/48
32 A	3	B	100326	Ex9BH 3P B32	1/4/48
40 A	3	B	100327	Ex9BH 3P B40	1/4/48
50 A	3	B	100328	Ex9BH 3P B50	1/4/48
63 A	3	B	100329	Ex9BH 3P B63	1/4/48

B-Characteristic, 3+N-pole



Rated current	Poles	Char.	Article No.	Type	Packing
1 A	3+N	B	100330	Ex9BH 3PN B1	1/3/36
2 A	3+N	B	100331	Ex9BH 3PN B2	1/3/36
3 A	3+N	B	100332	Ex9BH 3PN B3	1/3/36
4 A	3+N	B	100333	Ex9BH 3PN B4	1/3/36
6 A	3+N	B	100334	Ex9BH 3PN B6	1/3/36
8 A	3+N	B	100335	Ex9BH 3PN B8	1/3/36
10 A	3+N	B	100336	Ex9BH 3PN B10	1/3/36
13 A	3+N	B	100337	Ex9BH 3PN B13	1/3/36
16 A	3+N	B	100338	Ex9BH 3PN B16	1/3/36
20 A	3+N	B	100339	Ex9BH 3PN B20	1/3/36
25 A	3+N	B	100340	Ex9BH 3PN B25	1/3/36
32 A	3+N	B	100341	Ex9BH 3PN B32	1/3/36
40 A	3+N	B	100342	Ex9BH 3PN B40	1/3/36
50 A	3+N	B	100343	Ex9BH 3PN B50	1/3/36
63 A	3+N	B	100344	Ex9BH 3PN B63	1/3/36

B-Characteristic, 4-pole



Rated current	Poles	Char.	Article No.	Type	Packing
1 A	4	B	100345	Ex9BH 4P B1	1/3/36
2 A	4	B	100346	Ex9BH 4P B2	1/3/36
3 A	4	B	100347	Ex9BH 4P B3	1/3/36
4 A	4	B	100348	Ex9BH 4P B4	1/3/36
6 A	4	B	100349	Ex9BH 4P B6	1/3/36
8 A	4	B	100350	Ex9BH 4P B8	1/3/36
10 A	4	B	100351	Ex9BH 4P B10	1/3/36
13 A	4	B	100352	Ex9BH 4P B13	1/3/36
16 A	4	B	100353	Ex9BH 4P B16	1/3/36
20 A	4	B	100354	Ex9BH 4P B20	1/3/36
25 A	4	B	100355	Ex9BH 4P B25	1/3/36
32 A	4	B	100356	Ex9BH 4P B32	1/3/36
40 A	4	B	100357	Ex9BH 4P B40	1/3/36
50 A	4	B	100358	Ex9BH 4P B50	1/3/36
63 A	4	B	100359	Ex9BH 4P B63	1/3/36

Miniature Circuit Breakers Ex9BH, 10 kA

C-Characteristic, 1-pole



Rated current	Poles	Char.	Article No.	Type	Packing
1 A	1	C	100360	Ex9BH 1P C1	1/12/144
2 A	1	C	100361	Ex9BH 1P C2	1/12/144
3 A	1	C	100362	Ex9BH 1P C3	1/12/144
4 A	1	C	100363	Ex9BH 1P C4	1/12/144
6 A	1	C	100364	Ex9BH 1P C6	1/12/144
8 A	1	C	100365	Ex9BH 1P C8	1/12/144
10 A	1	C	100366	Ex9BH 1P C10	1/12/144
13 A	1	C	100367	Ex9BH 1P C13	1/12/144
16 A	1	C	100368	Ex9BH 1P C16	1/12/144
20 A	1	C	100369	Ex9BH 1P C20	1/12/144
25 A	1	C	100370	Ex9BH 1P C25	1/12/144
32 A	1	C	100371	Ex9BH 1P C32	1/12/144
40 A	1	C	100372	Ex9BH 1P C40	1/12/144
50 A	1	C	100373	Ex9BH 1P C50	1/12/144
63 A	1	C	100374	Ex9BH 1P C63	1/12/144

C-Characteristic, 1+N-pole



Rated current	Poles	Char.	Article No.	Type	Packing
1 A	1+N	C	100375	Ex9BH 1PN C1	1/6/72
2 A	1+N	C	100376	Ex9BH 1PN C2	1/6/72
3 A	1+N	C	100377	Ex9BH 1PN C3	1/6/72
4 A	1+N	C	100378	Ex9BH 1PN C4	1/6/72
6 A	1+N	C	100379	Ex9BH 1PN C6	1/6/72
8 A	1+N	C	100380	Ex9BH 1PN C8	1/6/72
10 A	1+N	C	100381	Ex9BH 1PN C10	1/6/72
13 A	1+N	C	100382	Ex9BH 1PN C13	1/6/72
16 A	1+N	C	100383	Ex9BH 1PN C16	1/6/72
20 A	1+N	C	100384	Ex9BH 1PN C20	1/6/72
25 A	1+N	C	100385	Ex9BH 1PN C25	1/6/72
32 A	1+N	C	100386	Ex9BH 1PN C32	1/6/72
40 A	1+N	C	100387	Ex9BH 1PN C40	1/6/72
50 A	1+N	C	100388	Ex9BH 1PN C50	1/6/72
63 A	1+N	C	100389	Ex9BH 1PN C63	1/6/72

C-Characteristic, 2-pole



Rated current	Poles	Char.	Article No.	Type	Packing
1 A	2	C	100390	Ex9BH 2P C1	1/6/72
2 A	2	C	100391	Ex9BH 2P C2	1/6/72
3 A	2	C	100392	Ex9BH 2P C3	1/6/72
4 A	2	C	100393	Ex9BH 2P C4	1/6/72
6 A	2	C	100394	Ex9BH 2P C6	1/6/72
8 A	2	C	100395	Ex9BH 2P C8	1/6/72
10 A	2	C	100396	Ex9BH 2P C10	1/6/72
13 A	2	C	100397	Ex9BH 2P C13	1/6/72
16 A	2	C	100398	Ex9BH 2P C16	1/6/72
20 A	2	C	100399	Ex9BH 2P C20	1/6/72
25 A	2	C	100400	Ex9BH 2P C25	1/6/72
32 A	2	C	100401	Ex9BH 2P C32	1/6/72
40 A	2	C	100402	Ex9BH 2P C40	1/6/72
50 A	2	C	100403	Ex9BH 2P C50	1/6/72
63 A	2	C	100404	Ex9BH 2P C63	1/6/72

Miniature Circuit Breakers Ex9BH, 10 kA

C-Characteristic, 3-pole



Rated current	Poles	Char.	Article No.	Type	Packing
1 A	3	C	100405	Ex9BH 3P C1	1/4/48
2 A	3	C	100406	Ex9BH 3P C2	1/4/48
3 A	3	C	100407	Ex9BH 3P C3	1/4/48
4 A	3	C	100408	Ex9BH 3P C4	1/4/48
6 A	3	C	100409	Ex9BH 3P C6	1/4/48
8 A	3	C	100410	Ex9BH 3P C8	1/4/48
10 A	3	C	100411	Ex9BH 3P C10	1/4/48
13 A	3	C	100412	Ex9BH 3P C13	1/4/48
16 A	3	C	100413	Ex9BH 3P C16	1/4/48
20 A	3	C	100414	Ex9BH 3P C20	1/4/48
25 A	3	C	100415	Ex9BH 3P C25	1/4/48
32 A	3	C	100416	Ex9BH 3P C32	1/4/48
40 A	3	C	100417	Ex9BH 3P C40	1/4/48
50 A	3	C	100418	Ex9BH 3P C50	1/4/48
63 A	3	C	100419	Ex9BH 3P C63	1/4/48

C-Characteristic, 3+N-pole



Rated current	Poles	Char.	Article No.	Type	Packing
1 A	3+N	C	100420	Ex9BH 3PN C1	1/3/36
2 A	3+N	C	100421	Ex9BH 3PN C2	1/3/36
3 A	3+N	C	100422	Ex9BH 3PN C3	1/3/36
4 A	3+N	C	100423	Ex9BH 3PN C4	1/3/36
6 A	3+N	C	100424	Ex9BH 3PN C6	1/3/36
8 A	3+N	C	100425	Ex9BH 3PN C8	1/3/36
10 A	3+N	C	100426	Ex9BH 3PN C10	1/3/36
13 A	3+N	C	100427	Ex9BH 3PN C13	1/3/36
16 A	3+N	C	100428	Ex9BH 3PN C16	1/3/36
20 A	3+N	C	100429	Ex9BH 3PN C20	1/3/36
25 A	3+N	C	100430	Ex9BH 3PN C25	1/3/36
32 A	3+N	C	100431	Ex9BH 3PN C32	1/3/36
40 A	3+N	C	100432	Ex9BH 3PN C40	1/3/36
50 A	3+N	C	100433	Ex9BH 3PN C50	1/3/36
63 A	3+N	C	100434	Ex9BH 3PN C63	1/3/36

C-Characteristic, 4-pole



Rated current	Poles	Char.	Article No.	Type	Packing
1 A	4	C	100435	Ex9BH 4P C1	1/3/36
2 A	4	C	100436	Ex9BH 4P C2	1/3/36
3 A	4	C	100437	Ex9BH 4P C3	1/3/36
4 A	4	C	100438	Ex9BH 4P C4	1/3/36
6 A	4	C	100439	Ex9BH 4P C6	1/3/36
8 A	4	C	100440	Ex9BH 4P C8	1/3/36
10 A	4	C	100441	Ex9BH 4P C10	1/3/36
13 A	4	C	100442	Ex9BH 4P C13	1/3/36
16 A	4	C	100443	Ex9BH 4P C16	1/3/36
20 A	4	C	100444	Ex9BH 4P C20	1/3/36
25 A	4	C	100445	Ex9BH 4P C25	1/3/36
32 A	4	C	100446	Ex9BH 4P C32	1/3/36
40 A	4	C	100447	Ex9BH 4P C40	1/3/36
50 A	4	C	100448	Ex9BH 4P C50	1/3/36
63 A	4	C	100449	Ex9BH 4P C63	1/3/36

Miniature Circuit Breakers Ex9BH, 10 kA

D-Characteristic, 1-pole



Rated current	Poles	Char.	Article No.	Type	Packing
1 A	1	D	100450	Ex9BH 1P D1	1/12/144
2 A	1	D	100451	Ex9BH 1P D2	1/12/144
3 A	1	D	100452	Ex9BH 1P D3	1/12/144
4 A	1	D	100453	Ex9BH 1P D4	1/12/144
6 A	1	D	100454	Ex9BH 1P D6	1/12/144
8 A	1	D	100455	Ex9BH 1P D8	1/12/144
10 A	1	D	100456	Ex9BH 1P D10	1/12/144
13 A	1	D	100457	Ex9BH 1P D13	1/12/144
16 A	1	D	100458	Ex9BH 1P D16	1/12/144
20 A	1	D	100459	Ex9BH 1P D20	1/12/144
25 A	1	D	100460	Ex9BH 1P D25	1/12/144
32 A	1	D	100461	Ex9BH 1P D32	1/12/144
40 A	1	D	100462	Ex9BH 1P D40	1/12/144
50 A	1	D	100463	Ex9BH 1P D50	1/12/144
63 A	1	D	100464	Ex9BH 1P D63	1/12/144

D-Characteristic, 1+N-pole



Rated current	Poles	Char.	Article No.	Type	Packing
1 A	1+N	D	100465	Ex9BH 1PN D1	1/6/72
2 A	1+N	D	100466	Ex9BH 1PN D2	1/6/72
3 A	1+N	D	100467	Ex9BH 1PN D3	1/6/72
4 A	1+N	D	100468	Ex9BH 1PN D4	1/6/72
6 A	1+N	D	100469	Ex9BH 1PN D6	1/6/72
8 A	1+N	D	100470	Ex9BH 1PN D8	1/6/72
10 A	1+N	D	100471	Ex9BH 1PN D10	1/6/72
13 A	1+N	D	100472	Ex9BH 1PN D13	1/6/72
16 A	1+N	D	100473	Ex9BH 1PN D16	1/6/72
20 A	1+N	D	100474	Ex9BH 1PN D20	1/6/72
25 A	1+N	D	100475	Ex9BH 1PN D25	1/6/72
32 A	1+N	D	100476	Ex9BH 1PN D32	1/6/72
40 A	1+N	D	100477	Ex9BH 1PN D40	1/6/72
50 A	1+N	D	100478	Ex9BH 1PN D50	1/6/72
63 A	1+N	D	100479	Ex9BH 1PN D63	1/6/72

D-Characteristic, 2-pole



Rated current	Poles	Char.	Article No.	Type	Packing
1 A	2	D	100480	Ex9BH 2P D1	1/6/72
2 A	2	D	100481	Ex9BH 2P D2	1/6/72
3 A	2	D	100482	Ex9BH 2P D3	1/6/72
4 A	2	D	100483	Ex9BH 2P D4	1/6/72
6 A	2	D	100484	Ex9BH 2P D6	1/6/72
8 A	2	D	100485	Ex9BH 2P D8	1/6/72
10 A	2	D	100486	Ex9BH 2P D10	1/6/72
13 A	2	D	100487	Ex9BH 2P D13	1/6/72
16 A	2	D	100488	Ex9BH 2P D16	1/6/72
20 A	2	D	100489	Ex9BH 2P D20	1/6/72
25 A	2	D	100490	Ex9BH 2P D25	1/6/72
32 A	2	D	100491	Ex9BH 2P D32	1/6/72
40 A	2	D	100492	Ex9BH 2P D40	1/6/72
50 A	2	D	100493	Ex9BH 2P D50	1/6/72
63 A	2	D	100494	Ex9BH 2P D63	1/6/72

Miniature Circuit Breakers Ex9BH, 10 kA

D-Characteristic, 3-pole



Rated current	Poles	Char.	Article No.	Type	Packing
1 A	3	D	100495	Ex9BH 3P D1	1/4/48
2 A	3	D	100496	Ex9BH 3P D2	1/4/48
3 A	3	D	100497	Ex9BH 3P D3	1/4/48
4 A	3	D	100498	Ex9BH 3P D4	1/4/48
6 A	3	D	100499	Ex9BH 3P D6	1/4/48
8 A	3	D	100500	Ex9BH 3P D8	1/4/48
10 A	3	D	100501	Ex9BH 3P D10	1/4/48
13 A	3	D	100502	Ex9BH 3P D13	1/4/48
16 A	3	D	100503	Ex9BH 3P D16	1/4/48
20 A	3	D	100504	Ex9BH 3P D20	1/4/48
25 A	3	D	100505	Ex9BH 3P D25	1/4/48
32 A	3	D	100506	Ex9BH 3P D32	1/4/48
40 A	3	D	100507	Ex9BH 3P D40	1/4/48
50 A	3	D	100508	Ex9BH 3P D50	1/4/48
63 A	3	D	100509	Ex9BH 3P D63	1/4/48

D-Characteristic, 3+N-pole



Rated current	Poles	Char.	Article No.	Type	Packing
1 A	3+N	D	100510	Ex9BH 3PN D1	1/3/36
2 A	3+N	D	100511	Ex9BH 3PN D2	1/3/36
3 A	3+N	D	100512	Ex9BH 3PN D3	1/3/36
4 A	3+N	D	100513	Ex9BH 3PN D4	1/3/36
6 A	3+N	D	100514	Ex9BH 3PN D6	1/3/36
8 A	3+N	D	100515	Ex9BH 3PN D8	1/3/36
10 A	3+N	D	100516	Ex9BH 3PN D10	1/3/36
13 A	3+N	D	100517	Ex9BH 3PN D13	1/3/36
16 A	3+N	D	100518	Ex9BH 3PN D16	1/3/36
20 A	3+N	D	100519	Ex9BH 3PN D20	1/3/36
25 A	3+N	D	100520	Ex9BH 3PN D25	1/3/36
32 A	3+N	D	100521	Ex9BH 3PN D32	1/3/36
40 A	3+N	D	100522	Ex9BH 3PN D40	1/3/36
50 A	3+N	D	100523	Ex9BH 3PN D50	1/3/36
63 A	3+N	D	100524	Ex9BH 3PN D63	1/3/36

D-Characteristic, 4-pole



Rated current	Poles	Char.	Article No.	Type	Packing
1 A	4	D	100525	Ex9BH 4P D1	1/3/36
2 A	4	D	100526	Ex9BH 4P D2	1/3/36
3 A	4	D	100527	Ex9BH 4P D3	1/3/36
4 A	4	D	100528	Ex9BH 4P D4	1/3/36
6 A	4	D	100529	Ex9BH 4P D6	1/3/36
8 A	4	D	100530	Ex9BH 4P D8	1/3/36
10 A	4	D	100531	Ex9BH 4P D10	1/3/36
13 A	4	D	100532	Ex9BH 4P D13	1/3/36
16 A	4	D	100533	Ex9BH 4P D16	1/3/36
20 A	4	D	100534	Ex9BH 4P D20	1/3/36
25 A	4	D	100535	Ex9BH 4P D25	1/3/36
32 A	4	D	100536	Ex9BH 4P D32	1/3/36
40 A	4	D	100537	Ex9BH 4P D40	1/3/36
50 A	4	D	100538	Ex9BH 4P D50	1/3/36
63 A	4	D	100539	Ex9BH 4P D63	1/3/36

Miniature Circuit Breakers Ex9BN, 6 kA



- Miniature Circuit Breakers according to IEC / EN 60898-1
- Rated short circuit breaking capacity I_{cn} 6 kA
- 1 up to 4-pole versions
- Tripping characteristics B, C, D
- Rated current up to 63 A
- Rated operational voltage 230/400 V AC, 48 V DC (per pole)
- Wide range of accessories

Ex9BN miniature circuit breakers are suitable for domestic as well as industrial applications. They can be combined with wide range of accessories including auxiliary and signal contacts, shunt trip release, undervoltage and overvoltage release or RCD add-on block. It is possible to create diversified combination of accessories. These combinations are only limited by total number, not by the type of accessories - all components fit together. It can be used up to three units of auxiliary or alarm contacts plus up to two units for release units.

Type Key

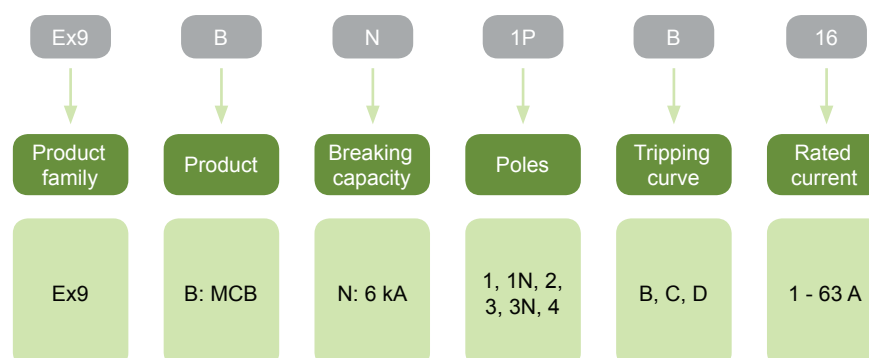

Certification marks



Miniature Circuit Breakers Ex9BN, 6 kA

Accessories



Auxiliary or signal contacts
AX, AL, AXL
Up to 3 units

Voltage or trip releases
SHT, UVT, OVT
Up to 2 units

MCB
Ex9B
1, 1+N, 2, 3, 3+N, 4-pole

RCD add-on block
Ex9LE
1+N, 2, 3, 3+N, 4-pole

Auxiliary contacts AX3111, AX3122

see page 72

Alarm contact AL3111

see page 72

Auxiliary and alarm contact AXL31

see page 72

Shunt trip releases SHT31, SHT3111

see page 72

Undervoltage releases UVT31, UVT3101, UVT3110

see page 73

Overtoltage release OVT31

see page 73

RCD add-on blocks Ex9LE

see page 65

RCD add-on blocks are mounted to the MCBs Ex9B from the right, the other accessories from the left and are identical for devices of the line Ex9B and Ex9PN.

Miniature Circuit Breakers Ex9BN, 6 kA

B-Characteristic, 1-pole



Rated current	Poles	Char.	Article No.	Type	Packing
1 A	1	B	100000	Ex9BN 1P B1	1/12/144
2 A	1	B	100001	Ex9BN 1P B2	1/12/144
3 A	1	B	100002	Ex9BN 1P B3	1/12/144
4 A	1	B	100003	Ex9BN 1P B4	1/12/144
6 A	1	B	100004	Ex9BN 1P B6	1/12/144
8 A	1	B	100005	Ex9BN 1P B8	1/12/144
10 A	1	B	100006	Ex9BN 1P B10	1/12/144
13 A	1	B	100007	Ex9BN 1P B13	1/12/144
16 A	1	B	100008	Ex9BN 1P B16	1/12/144
20 A	1	B	100009	Ex9BN 1P B20	1/12/144
25 A	1	B	100010	Ex9BN 1P B25	1/12/144
32 A	1	B	100011	Ex9BN 1P B32	1/12/144
40 A	1	B	100012	Ex9BN 1P B40	1/12/144
50 A	1	B	100013	Ex9BN 1P B50	1/12/144
63 A	1	B	100014	Ex9BN 1P B63	1/12/144

B-Characteristic, 1+N-pole



Rated current	Poles	Char.	Article No.	Type	Packing
1 A	1+N	B	100015	Ex9BN 1PN B1	1/6/72
2 A	1+N	B	100016	Ex9BN 1PN B2	1/6/72
3 A	1+N	B	100017	Ex9BN 1PN B3	1/6/72
4 A	1+N	B	100018	Ex9BN 1PN B4	1/6/72
6 A	1+N	B	100019	Ex9BN 1PN B6	1/6/72
8 A	1+N	B	100020	Ex9BN 1PN B8	1/6/72
10 A	1+N	B	100021	Ex9BN 1PN B10	1/6/72
13 A	1+N	B	100022	Ex9BN 1PN B13	1/6/72
16 A	1+N	B	100023	Ex9BN 1PN B16	1/6/72
20 A	1+N	B	100024	Ex9BN 1PN B20	1/6/72
25 A	1+N	B	100025	Ex9BN 1PN B25	1/6/72
32 A	1+N	B	100026	Ex9BN 1PN B32	1/6/72
40 A	1+N	B	100027	Ex9BN 1PN B40	1/6/72
50 A	1+N	B	100028	Ex9BN 1PN B50	1/6/72
63 A	1+N	B	100029	Ex9BN 1PN B63	1/6/72

B-Characteristic, 2-pole



Rated current	Poles	Char.	Article No.	Type	Packing
1 A	2	B	100030	Ex9BN 2P B1	1/6/72
2 A	2	B	100031	Ex9BN 2P B2	1/6/72
3 A	2	B	100032	Ex9BN 2P B3	1/6/72
4 A	2	B	100033	Ex9BN 2P B4	1/6/72
6 A	2	B	100034	Ex9BN 2P B6	1/6/72
8 A	2	B	100035	Ex9BN 2P B8	1/6/72
10 A	2	B	100036	Ex9BN 2P B10	1/6/72
13 A	2	B	100037	Ex9BN 2P B13	1/6/72
16 A	2	B	100038	Ex9BN 2P B16	1/6/72
20 A	2	B	100039	Ex9BN 2P B20	1/6/72
25 A	2	B	100040	Ex9BN 2P B25	1/6/72
32 A	2	B	100041	Ex9BN 2P B32	1/6/72
40 A	2	B	100042	Ex9BN 2P B40	1/6/72
50 A	2	B	100043	Ex9BN 2P B50	1/6/72
63 A	2	B	100044	Ex9BN 2P B63	1/6/72

Miniature Circuit Breakers Ex9BN, 6 kA

B-Characteristic, 3-pole



Rated current	Poles	Char.	Article No.	Type	Packing
1 A	3	B	100045	Ex9BN 3P B1	1/4/48
2 A	3	B	100046	Ex9BN 3P B2	1/4/48
3 A	3	B	100047	Ex9BN 3P B3	1/4/48
4 A	3	B	100048	Ex9BN 3P B4	1/4/48
6 A	3	B	100049	Ex9BN 3P B6	1/4/48
8 A	3	B	100050	Ex9BN 3P B8	1/4/48
10 A	3	B	100051	Ex9BN 3P B10	1/4/48
13 A	3	B	100052	Ex9BN 3P B13	1/4/48
16 A	3	B	100053	Ex9BN 3P B16	1/4/48
20 A	3	B	100054	Ex9BN 3P B20	1/4/48
25 A	3	B	100055	Ex9BN 3P B25	1/4/48
32 A	3	B	100056	Ex9BN 3P B32	1/4/48
40 A	3	B	100057	Ex9BN 3P B40	1/4/48
50 A	3	B	100058	Ex9BN 3P B50	1/4/48
63 A	3	B	100059	Ex9BN 3P B63	1/4/48

B-Characteristic, 3+N-pole



Rated current	Poles	Char.	Article No.	Type	Packing
1 A	3+N	B	100060	Ex9BN 3PN B1	1/3/36
2 A	3+N	B	100061	Ex9BN 3PN B2	1/3/36
3 A	3+N	B	100062	Ex9BN 3PN B3	1/3/36
4 A	3+N	B	100063	Ex9BN 3PN B4	1/3/36
6 A	3+N	B	100064	Ex9BN 3PN B6	1/3/36
8 A	3+N	B	100065	Ex9BN 3PN B8	1/3/36
10 A	3+N	B	100066	Ex9BN 3PN B10	1/3/36
13 A	3+N	B	100067	Ex9BN 3PN B13	1/3/36
16 A	3+N	B	100068	Ex9BN 3PN B16	1/3/36
20 A	3+N	B	100069	Ex9BN 3PN B20	1/3/36
25 A	3+N	B	100070	Ex9BN 3PN B25	1/3/36
32 A	3+N	B	100071	Ex9BN 3PN B32	1/3/36
40 A	3+N	B	100072	Ex9BN 3PN B40	1/3/36
50 A	3+N	B	100073	Ex9BN 3PN B50	1/3/36
63 A	3+N	B	100074	Ex9BN 3PN B63	1/3/36

B-Characteristic, 4-pole



Rated current	Poles	Char.	Article No.	Type	Packing
1 A	4	B	100075	Ex9BN 4P B1	1/3/36
2 A	4	B	100076	Ex9BN 4P B2	1/3/36
3 A	4	B	100077	Ex9BN 4P B3	1/3/36
4 A	4	B	100078	Ex9BN 4P B4	1/3/36
6 A	4	B	100079	Ex9BN 4P B6	1/3/36
8 A	4	B	100080	Ex9BN 4P B8	1/3/36
10 A	4	B	100081	Ex9BN 4P B10	1/3/36
13 A	4	B	100082	Ex9BN 4P B13	1/3/36
16 A	4	B	100083	Ex9BN 4P B16	1/3/36
20 A	4	B	100084	Ex9BN 4P B20	1/3/36
25 A	4	B	100085	Ex9BN 4P B25	1/3/36
32 A	4	B	100086	Ex9BN 4P B32	1/3/36
40 A	4	B	100087	Ex9BN 4P B40	1/3/36
50 A	4	B	100088	Ex9BN 4P B50	1/3/36
63 A	4	B	100089	Ex9BN 4P B63	1/3/36

Miniature Circuit Breakers Ex9BN, 6 kA

C-Characteristic, 1-pole



Rated current	Poles	Char.	Article No.	Type	Packing
1 A	1	C	100090	Ex9BN 1P C1	1/12/144
2 A	1	C	100091	Ex9BN 1P C2	1/12/144
3 A	1	C	100092	Ex9BN 1P C3	1/12/144
4 A	1	C	100093	Ex9BN 1P C4	1/12/144
6 A	1	C	100094	Ex9BN 1P C6	1/12/144
8 A	1	C	100095	Ex9BN 1P C8	1/12/144
10 A	1	C	100096	Ex9BN 1P C10	1/12/144
13 A	1	C	100097	Ex9BN 1P C13	1/12/144
16 A	1	C	100098	Ex9BN 1P C16	1/12/144
20 A	1	C	100099	Ex9BN 1P C20	1/12/144
25 A	1	C	100100	Ex9BN 1P C25	1/12/144
32 A	1	C	100101	Ex9BN 1P C32	1/12/144
40 A	1	C	100102	Ex9BN 1P C40	1/12/144
50 A	1	C	100103	Ex9BN 1P C50	1/12/144
63 A	1	C	100104	Ex9BN 1P C63	1/12/144

C-Characteristic, 1+N-pole



Rated current	Poles	Char.	Article No.	Type	Packing
1 A	1+N	C	100105	Ex9BN 1PN C1	1/6/72
2 A	1+N	C	100106	Ex9BN 1PN C2	1/6/72
3 A	1+N	C	100107	Ex9BN 1PN C3	1/6/72
4 A	1+N	C	100108	Ex9BN 1PN C4	1/6/72
6 A	1+N	C	100109	Ex9BN 1PN C6	1/6/72
8 A	1+N	C	100110	Ex9BN 1PN C8	1/6/72
10 A	1+N	C	100111	Ex9BN 1PN C10	1/6/72
13 A	1+N	C	100112	Ex9BN 1PN C13	1/6/72
16 A	1+N	C	100113	Ex9BN 1PN C16	1/6/72
20 A	1+N	C	100114	Ex9BN 1PN C20	1/6/72
25 A	1+N	C	100115	Ex9BN 1PN C25	1/6/72
32 A	1+N	C	100116	Ex9BN 1PN C32	1/6/72
40 A	1+N	C	100117	Ex9BN 1PN C40	1/6/72
50 A	1+N	C	100118	Ex9BN 1PN C50	1/6/72
63 A	1+N	C	100119	Ex9BN 1PN C63	1/6/72

C-Characteristic, 2-pole



Rated current	Poles	Char.	Article No.	Type	Packing
1 A	2	C	100120	Ex9BN 2P C1	1/6/72
2 A	2	C	100121	Ex9BN 2P C2	1/6/72
3 A	2	C	100122	Ex9BN 2P C3	1/6/72
4 A	2	C	100123	Ex9BN 2P C4	1/6/72
6 A	2	C	100124	Ex9BN 2P C6	1/6/72
8 A	2	C	100125	Ex9BN 2P C8	1/6/72
10 A	2	C	100126	Ex9BN 2P C10	1/6/72
13 A	2	C	100127	Ex9BN 2P C13	1/6/72
16 A	2	C	100128	Ex9BN 2P C16	1/6/72
20 A	2	C	100129	Ex9BN 2P C20	1/6/72
25 A	2	C	100130	Ex9BN 2P C25	1/6/72
32 A	2	C	100131	Ex9BN 2P C32	1/6/72
40 A	2	C	100132	Ex9BN 2P C40	1/6/72
50 A	2	C	100133	Ex9BN 2P C50	1/6/72
63 A	2	C	100134	Ex9BN 2P C63	1/6/72

Miniature Circuit Breakers Ex9BN, 6 kA

C-Characteristic, 3-pole



Rated current	Poles	Char.	Article No.	Type	Packing
1 A	3	C	100135	Ex9BN 3P C1	1/4/48
2 A	3	C	100136	Ex9BN 3P C2	1/4/48
3 A	3	C	100137	Ex9BN 3P C3	1/4/48
4 A	3	C	100138	Ex9BN 3P C4	1/4/48
6 A	3	C	100139	Ex9BN 3P C6	1/4/48
8 A	3	C	100140	Ex9BN 3P C8	1/4/48
10 A	3	C	100141	Ex9BN 3P C10	1/4/48
13 A	3	C	100142	Ex9BN 3P C13	1/4/48
16 A	3	C	100143	Ex9BN 3P C16	1/4/48
20 A	3	C	100144	Ex9BN 3P C20	1/4/48
25 A	3	C	100145	Ex9BN 3P C25	1/4/48
32 A	3	C	100146	Ex9BN 3P C32	1/4/48
40 A	3	C	100147	Ex9BN 3P C40	1/4/48
50 A	3	C	100148	Ex9BN 3P C50	1/4/48
63 A	3	C	100149	Ex9BN 3P C63	1/4/48

C-Characteristic, 3+N-pole



Rated current	Poles	Char.	Article No.	Type	Packing
1 A	3+N	C	100150	Ex9BN 3PN C1	1/3/36
2 A	3+N	C	100151	Ex9BN 3PN C2	1/3/36
3 A	3+N	C	100152	Ex9BN 3PN C3	1/3/36
4 A	3+N	C	100153	Ex9BN 3PN C4	1/3/36
6 A	3+N	C	100154	Ex9BN 3PN C6	1/3/36
8 A	3+N	C	100155	Ex9BN 3PN C8	1/3/36
10 A	3+N	C	100156	Ex9BN 3PN C10	1/3/36
13 A	3+N	C	100157	Ex9BN 3PN C13	1/3/36
16 A	3+N	C	100158	Ex9BN 3PN C16	1/3/36
20 A	3+N	C	100159	Ex9BN 3PN C20	1/3/36
25 A	3+N	C	100160	Ex9BN 3PN C25	1/3/36
32 A	3+N	C	100161	Ex9BN 3PN C32	1/3/36
40 A	3+N	C	100162	Ex9BN 3PN C40	1/3/36
50 A	3+N	C	100163	Ex9BN 3PN C50	1/3/36
63 A	3+N	C	100164	Ex9BN 3PN C63	1/3/36

C-Characteristic, 4-pole



Rated current	Poles	Char.	Article No.	Type	Packing
1 A	4	C	100165	Ex9BN 4P C1	1/3/36
2 A	4	C	100166	Ex9BN 4P C2	1/3/36
3 A	4	C	100167	Ex9BN 4P C3	1/3/36
4 A	4	C	100168	Ex9BN 4P C4	1/3/36
6 A	4	C	100169	Ex9BN 4P C6	1/3/36
8 A	4	C	100170	Ex9BN 4P C8	1/3/36
10 A	4	C	100171	Ex9BN 4P C10	1/3/36
13 A	4	C	100172	Ex9BN 4P C13	1/3/36
16 A	4	C	100173	Ex9BN 4P C16	1/3/36
20 A	4	C	100174	Ex9BN 4P C20	1/3/36
25 A	4	C	100175	Ex9BN 4P C25	1/3/36
32 A	4	C	100176	Ex9BN 4P C32	1/3/36
40 A	4	C	100177	Ex9BN 4P C40	1/3/36
50 A	4	C	100178	Ex9BN 4P C50	1/3/36
63 A	4	C	100179	Ex9BN 4P C63	1/3/36

Miniature Circuit Breakers Ex9BN, 6 kA

D-Characteristic, 1-pole



Rated current	Poles	Char.	Article No.	Type	Packing
1 A	1	D	100180	Ex9BN 1P D1	1/12/144
2 A	1	D	100181	Ex9BN 1P D2	1/12/144
3 A	1	D	100182	Ex9BN 1P D3	1/12/144
4 A	1	D	100183	Ex9BN 1P D4	1/12/144
6 A	1	D	100184	Ex9BN 1P D6	1/12/144
8 A	1	D	100185	Ex9BN 1P D8	1/12/144
10 A	1	D	100186	Ex9BN 1P D10	1/12/144
13 A	1	D	100187	Ex9BN 1P D13	1/12/144
16 A	1	D	100188	Ex9BN 1P D16	1/12/144
20 A	1	D	100189	Ex9BN 1P D20	1/12/144
25 A	1	D	100190	Ex9BN 1P D25	1/12/144
32 A	1	D	100191	Ex9BN 1P D32	1/12/144
40 A	1	D	100192	Ex9BN 1P D40	1/12/144
50 A	1	D	100193	Ex9BN 1P D50	1/12/144
63 A	1	D	100194	Ex9BN 1P D63	1/12/144

D-Characteristic, 1+N-pole



Rated current	Poles	Char.	Article No.	Type	Packing
1 A	1+N	D	100195	Ex9BN 1PN D1	1/6/72
2 A	1+N	D	100196	Ex9BN 1PN D2	1/6/72
3 A	1+N	D	100197	Ex9BN 1PN D3	1/6/72
4 A	1+N	D	100198	Ex9BN 1PN D4	1/6/72
6 A	1+N	D	100199	Ex9BN 1PN D6	1/6/72
8 A	1+N	D	100200	Ex9BN 1PN D8	1/6/72
10 A	1+N	D	100201	Ex9BN 1PN D10	1/6/72
13 A	1+N	D	100202	Ex9BN 1PN D13	1/6/72
16 A	1+N	D	100203	Ex9BN 1PN D16	1/6/72
20 A	1+N	D	100204	Ex9BN 1PN D20	1/6/72
25 A	1+N	D	100205	Ex9BN 1PN D25	1/6/72
32 A	1+N	D	100206	Ex9BN 1PN D32	1/6/72
40 A	1+N	D	100207	Ex9BN 1PN D40	1/6/72
50 A	1+N	D	100208	Ex9BN 1PN D50	1/6/72
63 A	1+N	D	100209	Ex9BN 1PN D63	1/6/72

D-Characteristic, 2-pole



Rated current	Poles	Char.	Article No.	Type	Packing
1 A	2	D	100210	Ex9BN 2P D1	1/6/72
2 A	2	D	100211	Ex9BN 2P D2	1/6/72
3 A	2	D	100212	Ex9BN 2P D3	1/6/72
4 A	2	D	100213	Ex9BN 2P D4	1/6/72
6 A	2	D	100214	Ex9BN 2P D6	1/6/72
8 A	2	D	100215	Ex9BN 2P D8	1/6/72
10 A	2	D	100216	Ex9BN 2P D10	1/6/72
13 A	2	D	100217	Ex9BN 2P D13	1/6/72
16 A	2	D	100218	Ex9BN 2P D16	1/6/72
20 A	2	D	100219	Ex9BN 2P D20	1/6/72
25 A	2	D	100220	Ex9BN 2P D25	1/6/72
32 A	2	D	100221	Ex9BN 2P D32	1/6/72
40 A	2	D	100222	Ex9BN 2P D40	1/6/72
50 A	2	D	100223	Ex9BN 2P D50	1/6/72
63 A	2	D	100224	Ex9BN 2P D63	1/6/72

Miniature Circuit Breakers Ex9BN, 6 kA

D-Characteristic, 3-pole



Rated current	Poles	Char.	Article No.	Type	Packing
1 A	3	D	100225	Ex9BN 3P D1	1/4/48
2 A	3	D	100226	Ex9BN 3P D2	1/4/48
3 A	3	D	100227	Ex9BN 3P D3	1/4/48
4 A	3	D	100228	Ex9BN 3P D4	1/4/48
6 A	3	D	100229	Ex9BN 3P D6	1/4/48
8 A	3	D	100230	Ex9BN 3P D8	1/4/48
10 A	3	D	100231	Ex9BN 3P D10	1/4/48
13 A	3	D	100232	Ex9BN 3P D13	1/4/48
16 A	3	D	100233	Ex9BN 3P D16	1/4/48
20 A	3	D	100234	Ex9BN 3P D20	1/4/48
25 A	3	D	100235	Ex9BN 3P D25	1/4/48
32 A	3	D	100236	Ex9BN 3P D32	1/4/48
40 A	3	D	100237	Ex9BN 3P D40	1/4/48
50 A	3	D	100238	Ex9BN 3P D50	1/4/48
63 A	3	D	100239	Ex9BN 3P D63	1/4/48

D-Characteristic, 3+N-pole



Rated current	Poles	Char.	Article No.	Type	Packing
1 A	3+N	D	100240	Ex9BN 3PN D1	1/3/36
2 A	3+N	D	100241	Ex9BN 3PN D2	1/3/36
3 A	3+N	D	100242	Ex9BN 3PN D3	1/3/36
4 A	3+N	D	100243	Ex9BN 3PN D4	1/3/36
6 A	3+N	D	100244	Ex9BN 3PN D6	1/3/36
8 A	3+N	D	100245	Ex9BN 3PN D8	1/3/36
10 A	3+N	D	100246	Ex9BN 3PN D10	1/3/36
13 A	3+N	D	100247	Ex9BN 3PN D13	1/3/36
16 A	3+N	D	100248	Ex9BN 3PN D16	1/3/36
20 A	3+N	D	100249	Ex9BN 3PN D20	1/3/36
25 A	3+N	D	100250	Ex9BN 3PN D25	1/3/36
32 A	3+N	D	100251	Ex9BN 3PN D32	1/3/36
40 A	3+N	D	100252	Ex9BN 3PN D40	1/3/36
50 A	3+N	D	100253	Ex9BN 3PN D50	1/3/36
63 A	3+N	D	100254	Ex9BN 3PN D63	1/3/36

D-Characteristic, 4-pole



Rated current	Poles	Char.	Article No.	Type	Packing
1 A	4	D	100255	Ex9BN 4P D1	1/3/36
2 A	4	D	100256	Ex9BN 4P D2	1/3/36
3 A	4	D	100257	Ex9BN 4P D3	1/3/36
4 A	4	D	100258	Ex9BN 4P D4	1/3/36
6 A	4	D	100259	Ex9BN 4P D6	1/3/36
8 A	4	D	100260	Ex9BN 4P D8	1/3/36
10 A	4	D	100261	Ex9BN 4P D10	1/3/36
13 A	4	D	100262	Ex9BN 4P D13	1/3/36
16 A	4	D	100263	Ex9BN 4P D16	1/3/36
20 A	4	D	100264	Ex9BN 4P D20	1/3/36
25 A	4	D	100265	Ex9BN 4P D25	1/3/36
32 A	4	D	100266	Ex9BN 4P D32	1/3/36
40 A	4	D	100267	Ex9BN 4P D40	1/3/36
50 A	4	D	100268	Ex9BN 4P D50	1/3/36
63 A	4	D	100269	Ex9BN 4P D63	1/3/36

Miniature Circuit Breakers Ex9B125



- Miniature Circuit Breakers up to 125 A
- Tested according to EN 60947-2
- High rated breaking capacities:
up to 25 kA acc. to EN 60947-2
up to 20 kA acc. to EN 60898-1
- 1 up to 4-pole versions
- Rated operating voltage 230/400 V AC
- Tripping characteristics B, C, D according to EN 60898-1
- Wide range of accessories
- Toggle colour according to rated current I_n

Miniature Circuit Breakers Ex9B125 are suitable mainly for power distribution and industrial applications for short-circuit and overload current protection with rated current up to 125 A and very high rated breaking capacities (tested according to EN 60947-2 as well as EN 60898-1).

These breakers can be combined with wide range of accessories (same as for Ex9B breakers) including auxiliary and signal contacts, shunt trip releases, undervoltage and overvoltage releases. It is possible to create diversified combination of accessories.

Type Key

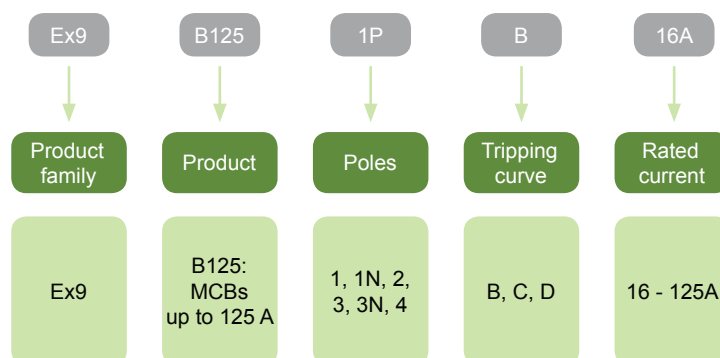

Certification marks



Miniature Circuit Breakers Ex9B125

Accessories



Auxiliary or signal contacts
AX, AL, AXL
Up to 3 units

Voltage or trip releases
SHT, UVT, OVT
Up to 2 units

MCB
Ex9B125
1, 1+N, 2, 3, 3+N, 4-pole

Auxiliary contacts AX3111, AX3122

see page 72

Alarm contact AL3111

see page 72

Auxiliary and alarm contact AXL31

see page 72

Shunt trip releases SHT31, SHT3111

see page 72

Undervoltage releases UVT31, UVT3101, UVT3110

see page 73

Overtoltage release OVT31

see page 73

All accessories are mounted to the breaker from the left side and are identical for devices of the line Ex9B and Ex9PN.

Miniature Circuit Breakers Ex9B125

B-Characteristic

- Rated ultimate short-circuit breaking capacity I_{cu} (EN 60947-2)
 - for I_n 16 - 63 A = 25 kA
 - for I_n 80, 100 A = 20 kA
 - for I_n 125 A = 15 kA

- Rated short-circuit breaking capacity I_{cn} (EN 60898-1)
 - for I_n 16 - 63 A = 20 kA
 - for I_n 80, 100 A = 15 kA
 - for I_n 125 A = 10 kA



Rated current	Poles	Char.	Article No.	Type	Packing
16 A	1	B	102684	Ex9B125 1P B16A	1/12/108
20 A	1	B	102685	Ex9B125 1P B20A	1/12/108
25 A	1	B	102686	Ex9B125 1P B25A	1/12/108
32 A	1	B	102687	Ex9B125 1P B32A	1/12/108
40 A	1	B	102688	Ex9B125 1P B40A	1/12/108
50 A	1	B	102689	Ex9B125 1P B50A	1/12/108
63 A	1	B	102690	Ex9B125 1P B63A	1/12/108
80 A	1	B	102691	Ex9B125 1P B80A	1/12/108
100 A	1	B	102692	Ex9B125 1P B100A	1/12/108
125 A	1	B	102693	Ex9B125 1P B125A	1/12/108
16 A	1+N	B	102714	Ex9B125 1PN B16A	1/6/54
20 A	1+N	B	102715	Ex9B125 1PN B20A	1/6/54
25 A	1+N	B	102716	Ex9B125 1PN B25A	1/6/54
32 A	1+N	B	102717	Ex9B125 1PN B32A	1/6/54
40 A	1+N	B	102718	Ex9B125 1PN B40A	1/6/54
50 A	1+N	B	102719	Ex9B125 1PN B50A	1/6/54
63 A	1+N	B	102720	Ex9B125 1PN B63A	1/6/54
80 A	1+N	B	102721	Ex9B125 1PN B80A	1/6/54
100 A	1+N	B	102722	Ex9B125 1PN B100A	1/6/54
125 A	1+N	B	102723	Ex9B125 1PN B125A	1/6/54
16 A	2	B	102744	Ex9B125 2P B16A	1/6/54
20 A	2	B	102745	Ex9B125 2P B20A	1/6/54
25 A	2	B	102746	Ex9B125 2P B25A	1/6/54
32 A	2	B	102747	Ex9B125 2P B32A	1/6/54
40 A	2	B	102748	Ex9B125 2P B40A	1/6/54
50 A	2	B	102749	Ex9B125 2P B50A	1/6/54
63 A	2	B	102750	Ex9B125 2P B63A	1/6/54
80 A	2	B	102751	Ex9B125 2P B80A	1/6/54
100 A	2	B	102752	Ex9B125 2P B100A	1/6/54
125 A	2	B	102753	Ex9B125 2P B125A	1/6/54
16 A	3	B	102774	Ex9B125 3P B16A	1/4/36
20 A	3	B	102775	Ex9B125 3P B20A	1/4/36
25 A	3	B	102776	Ex9B125 3P B25A	1/4/36
32 A	3	B	102777	Ex9B125 3P B32A	1/4/36
40 A	3	B	102778	Ex9B125 3P B40A	1/4/36
50 A	3	B	102779	Ex9B125 3P B50A	1/4/36
63 A	3	B	102780	Ex9B125 3P B63A	1/4/36
80 A	3	B	102781	Ex9B125 3P B80A	1/4/36
100 A	3	B	102782	Ex9B125 3P B100A	1/4/36
125 A	3	B	102783	Ex9B125 3P B125A	1/4/36
16 A	3+N	B	102804	Ex9B125 3PN B16A	1/3/27
20 A	3+N	B	102805	Ex9B125 3PN B20A	1/3/27
25 A	3+N	B	102806	Ex9B125 3PN B25A	1/3/27
32 A	3+N	B	102807	Ex9B125 3PN B32A	1/3/27
40 A	3+N	B	102808	Ex9B125 3PN B40A	1/3/27
50 A	3+N	B	102809	Ex9B125 3PN B50A	1/3/27
63 A	3+N	B	102810	Ex9B125 3PN B63A	1/3/27
80 A	3+N	B	102811	Ex9B125 3PN B80A	1/3/27
100 A	3+N	B	102812	Ex9B125 3PN B100A	1/3/27
125 A	3+N	B	102813	Ex9B125 3PN B125A	1/3/27
16 A	4	B	102834	Ex9B125 4P B16A	1/3/27
20 A	4	B	102835	Ex9B125 4P B20A	1/3/27
25 A	4	B	102836	Ex9B125 4P B25A	1/3/27
32 A	4	B	102837	Ex9B125 4P B32A	1/3/27
40 A	4	B	102838	Ex9B125 4P B40A	1/3/27
50 A	4	B	102839	Ex9B125 4P B50A	1/3/27
63 A	4	B	102840	Ex9B125 4P B63A	1/3/27
80 A	4	B	102841	Ex9B125 4P B80A	1/3/27
100 A	4	B	102842	Ex9B125 4P B100A	1/3/27
125 A	4	B	102843	Ex9B125 4P B125A	1/3/27

Miniature Circuit Breakers Ex9B125

C-Characteristic

- Rated ultimate short-circuit breaking capacity I_{cu} (EN 60947-2)
 - for I_n 16 - 63 A = 25 kA
 - for I_n 80, 100 A = 20 kA
 - for I_n 125 A = 15 kA
- Rated short-circuit breaking capacity I_{cn} (EN 60898-1)
 - for I_n 16 - 63 A = 20 kA
 - for I_n 80, 100 A = 15 kA
 - for I_n 125 A = 10 kA



Rated current	Poles	Char.	Article No.	Type	Packing
16 A	1	C	102694	Ex9B125 1P C16A	1/12/108
20 A	1	C	102695	Ex9B125 1P C20A	1/12/108
25 A	1	C	102696	Ex9B125 1P C25A	1/12/108
32 A	1	C	102697	Ex9B125 1P C32A	1/12/108
40 A	1	C	102698	Ex9B125 1P C40A	1/12/108
50 A	1	C	102699	Ex9B125 1P C50A	1/12/108
63 A	1	C	102700	Ex9B125 1P C63A	1/12/108
80 A	1	C	102701	Ex9B125 1P C80A	1/12/108
100 A	1	C	102702	Ex9B125 1P C100A	1/12/108
125 A	1	C	102703	Ex9B125 1P C125A	1/12/108
16 A	1+N	C	102724	Ex9B125 1PN C16A	1/6/54
20 A	1+N	C	102725	Ex9B125 1PN C20A	1/6/54
25 A	1+N	C	102726	Ex9B125 1PN C25A	1/6/54
32 A	1+N	C	102727	Ex9B125 1PN C32A	1/6/54
40 A	1+N	C	102728	Ex9B125 1PN C40A	1/6/54
50 A	1+N	C	102729	Ex9B125 1PN C50A	1/6/54
63 A	1+N	C	102730	Ex9B125 1PN C63A	1/6/54
80 A	1+N	C	102731	Ex9B125 1PN C80A	1/6/54
100 A	1+N	C	102732	Ex9B125 1PN C100A	1/6/54
125 A	1+N	C	102733	Ex9B125 1PN C125A	1/6/54
16 A	2	C	102754	Ex9B125 2P C16A	1/6/54
20 A	2	C	102755	Ex9B125 2P C20A	1/6/54
25 A	2	C	102756	Ex9B125 2P C25A	1/6/54
32 A	2	C	102757	Ex9B125 2P C32A	1/6/54
40 A	2	C	102758	Ex9B125 2P C40A	1/6/54
50 A	2	C	102759	Ex9B125 2P C50A	1/6/54
63 A	2	C	102760	Ex9B125 2P C63A	1/6/54
80 A	2	C	102761	Ex9B125 2P C80A	1/6/54
100 A	2	C	102762	Ex9B125 2P C100A	1/6/54
125 A	2	C	102763	Ex9B125 2P C125A	1/6/54
16 A	3	C	102784	Ex9B125 3P C16A	1/4/36
20 A	3	C	102785	Ex9B125 3P C20A	1/4/36
25 A	3	C	102786	Ex9B125 3P C25A	1/4/36
32 A	3	C	102787	Ex9B125 3P C32A	1/4/36
40 A	3	C	102788	Ex9B125 3P C40A	1/4/36
50 A	3	C	102789	Ex9B125 3P C50A	1/4/36
63 A	3	C	102790	Ex9B125 3P C63A	1/4/36
80 A	3	C	102791	Ex9B125 3P C80A	1/4/36
100 A	3	C	102792	Ex9B125 3P C100A	1/4/36
125 A	3	C	102793	Ex9B125 3P C125A	1/4/36
16 A	3+N	C	102814	Ex9B125 3PN C16A	1/3/27
20 A	3+N	C	102815	Ex9B125 3PN C20A	1/3/27
25 A	3+N	C	102816	Ex9B125 3PN C25A	1/3/27
32 A	3+N	C	102817	Ex9B125 3PN C32A	1/3/27
40 A	3+N	C	102818	Ex9B125 3PN C40A	1/3/27
50 A	3+N	C	102819	Ex9B125 3PN C50A	1/3/27
63 A	3+N	C	102820	Ex9B125 3PN C63A	1/3/27
80 A	3+N	C	102821	Ex9B125 3PN C80A	1/3/27
100 A	3+N	C	102822	Ex9B125 3PN C100A	1/3/27
125 A	3+N	C	102823	Ex9B125 3PN C125A	1/3/27
16 A	4	C	102844	Ex9B125 4P C16A	1/3/27
20 A	4	C	102845	Ex9B125 4P C20A	1/3/27
25 A	4	C	102846	Ex9B125 4P C25A	1/3/27
32 A	4	C	102847	Ex9B125 4P C32A	1/3/27
40 A	4	C	102848	Ex9B125 4P C40A	1/3/27
50 A	4	C	102849	Ex9B125 4P C50A	1/3/27
63 A	4	C	102850	Ex9B125 4P C63A	1/3/27
80 A	4	C	102851	Ex9B125 4P C80A	1/3/27
100 A	4	C	102852	Ex9B125 4P C100A	1/3/27
125 A	4	C	102853	Ex9B125 4P C125A	1/3/27

Miniature Circuit Breakers Ex9B125

D-Characteristic

- Rated ultimate short-circuit breaking capacity I_{cu} (EN 60947-2)
 - for I_n 16 - 63 A = 25 kA
 - for I_n 80, 100 A = 20 kA
 - for I_n 125 A = 15 kA
- Rated short-circuit breaking capacity I_{cn} (EN 60898-1)
 - for I_n 16 - 63 A = 20 kA
 - for I_n 80, 100 A = 15 kA
 - for I_n 125 A = 10 kA



Rated current	Poles	Char.	Article No.	Type	Packing
16 A	1	D	102704	Ex9B125 1P D16 A	1/12/108
20 A	1	D	102705	Ex9B125 1P D20A	1/12/108
25 A	1	D	102706	Ex9B125 1P D25A	1/12/108
32 A	1	D	102707	Ex9B125 1P D32A	1/12/108
40 A	1	D	102708	Ex9B125 1P D40A	1/12/108
50 A	1	D	102709	Ex9B125 1P D50A	1/12/108
63 A	1	D	102710	Ex9B125 1P D63A	1/12/108
80 A	1	D	102711	Ex9B125 1P D80A	1/12/108
100 A	1	D	102712	Ex9B125 1P D100A	1/12/108
125 A	1	D	102713	Ex9B125 1P D125A	1/12/108
16 A	1+N	D	102734	Ex9B125 1PN D16A	1/6/54
20 A	1+N	D	102735	Ex9B125 1PN D20A	1/6/54
25 A	1+N	D	102736	Ex9B125 1PN D25A	1/6/54
32 A	1+N	D	102737	Ex9B125 1PN D32A	1/6/54
40 A	1+N	D	102738	Ex9B125 1PN D40A	1/6/54
50 A	1+N	D	102739	Ex9B125 1PN D50A	1/6/54
63 A	1+N	D	102740	Ex9B125 1PN D63A	1/6/54
80 A	1+N	D	102741	Ex9B125 1PN D80A	1/6/54
100 A	1+N	D	102742	Ex9B125 1PN D100A	1/6/54
125 A	1+N	D	102743	Ex9B125 1PN D125A	1/6/54
16 A	2	D	102764	Ex9B125 2P D16A	1/6/54
20 A	2	D	102765	Ex9B125 2P D20A	1/6/54
25 A	2	D	102766	Ex9B125 2P D25A	1/6/54
32 A	2	D	102767	Ex9B125 2P D32A	1/6/54
40 A	2	D	102768	Ex9B125 2P D40A	1/6/54
50 A	2	D	102769	Ex9B125 2P D50A	1/6/54
63 A	2	D	102770	Ex9B125 2P D63A	1/6/54
80 A	2	D	102771	Ex9B125 2P D80A	1/6/54
100 A	2	D	102772	Ex9B125 2P D100A	1/6/54
125 A	2	D	102773	Ex9B125 2P D125A	1/6/54
16 A	3	D	102794	Ex9B125 3P D16A	1/4/36
20 A	3	D	102795	Ex9B125 3P D20A	1/4/36
25 A	3	D	102796	Ex9B125 3P D25A	1/4/36
32 A	3	D	102797	Ex9B125 3P D32A	1/4/36
40 A	3	D	102798	Ex9B125 3P D40A	1/4/36
50 A	3	D	102799	Ex9B125 3P D50A	1/4/36
63 A	3	D	102800	Ex9B125 3P D63A	1/4/36
80 A	3	D	102801	Ex9B125 3P D80A	1/4/36
100 A	3	D	102802	Ex9B125 3P D100A	1/4/36
125 A	3	D	102803	Ex9B125 3P D125A	1/4/36
16 A	3+N	D	102824	Ex9B125 3PN D16A	1/3/27
20 A	3+N	D	102825	Ex9B125 3PN D20A	1/3/27
25 A	3+N	D	102826	Ex9B125 3PN D25A	1/3/27
32 A	3+N	D	102827	Ex9B125 3PN D32A	1/3/27
40 A	3+N	D	102828	Ex9B125 3PN D40A	1/3/27
50 A	3+N	D	102829	Ex9B125 3PN D50A	1/3/27
63 A	3+N	D	102830	Ex9B125 3PN D63A	1/3/27
80 A	3+N	D	102831	Ex9B125 3PN D80A	1/3/27
100 A	3+N	D	102832	Ex9B125 3PN D100A	1/3/27
125 A	3+N	D	102833	Ex9B125 3PN D125A	1/3/27
16 A	4	D	102854	Ex9B125 4P D16A	1/3/27
20 A	4	D	102855	Ex9B125 4P D20A	1/3/27
25 A	4	D	102856	Ex9B125 4P D25A	1/3/27
32 A	4	D	102857	Ex9B125 4P D32A	1/3/27
40 A	4	D	102858	Ex9B125 4P D40A	1/3/27
50 A	4	D	102859	Ex9B125 4P D50A	1/3/27
63 A	4	D	102860	Ex9B125 4P D63A	1/3/27
80 A	4	D	102861	Ex9B125 4P D80A	1/3/27
100 A	4	D	102862	Ex9B125 4P D100A	1/3/27
125 A	4	D	102863	Ex9B125 4P D125A	1/3/27

Miniature Circuit Breakers Ex9PN-N



- Miniature Circuit Breakers according to IEC / EN 60898-1
- 1+N pole MCB in one module design
- Rated short circuit breaking capacity I_{cn} 6 kA
- Tripping characteristics B, C
- Rated current up to 40 A
- Rated operational voltage 230/400 V AC, 48 V DC (per pole)
- Wide range of accessories

Ex9PN-N miniature circuit breakers are suitable for domestic as well as industrial applications. They can be combined with wide range of accessories including auxiliary and signal contacts, shunt trip release, undervoltage and overvoltage release. It is possible to create diversified combination of accessories. These combinations are only limited by total number, not by the type of accessories - all components fit together. It can be used up to three units of auxiliary or alarm contacts plus up to two units for release units.

Type Key

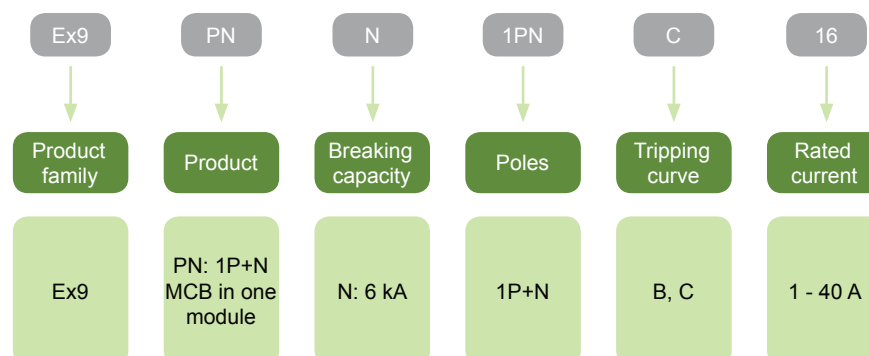

Certification marks



Miniature Circuit Breakers Ex9PN-N

Accessories



Auxiliary or signal contacts
AX, AL, AXL
Up to 3 units

Voltage or trip releases
SHT, UVT, OVT
Up to 2 units

MCB
Ex9PN
1+N-pole

Auxiliary contacts AX3111, AX3122

see page 72

Alarm contact AL3111

see page 72

Auxiliary and alarm contact AXL31

see page 72

Shunt trip releases SHT31, SHT3111

see page 72

Undervoltage releases UVT31, UVT3101, UVT3110

see page 73

Overvoltage release OVT31

see page 73

All accessories are mounted from the left side and are identical for devices of the line Ex9B and Ex9PN.

Miniature Circuit Breakers Ex9PN-N

B-Characteristic, 6 kA



Rated current	Poles	Char.	Article No.	Type	Packing
1 A	1+N	B	101600	Ex9PN-N 1PN B1	1/12/144
2 A	1+N	B	101601	Ex9PN-N 1PN B2	1/12/144
3 A	1+N	B	101602	Ex9PN-N 1PN B3	1/12/144
4 A	1+N	B	101603	Ex9PN-N 1PN B4	1/12/144
6 A	1+N	B	101604	Ex9PN-N 1PN B6	1/12/144
10 A	1+N	B	101605	Ex9PN-N 1PN B10	1/12/144
13 A	1+N	B	102354	Ex9PN-N 1PN B13	1/12/144
16 A	1+N	B	101606	Ex9PN-N 1PN B16	1/12/144
20 A	1+N	B	101607	Ex9PN-N 1PN B20	1/12/144
25 A	1+N	B	101608	Ex9PN-N 1PN B25	1/12/144
32 A	1+N	B	101609	Ex9PN-N 1PN B32	1/12/144
40 A	1+N	B	101610	Ex9PN-N 1PN B40	1/12/144

C-Characteristic, 6 kA



Rated current	Poles	Char.	Article No.	Type	Packing
1 A	1+N	C	101611	Ex9PN-N 1PN C1	1/12/144
2 A	1+N	C	101612	Ex9PN-N 1PN C2	1/12/144
3 A	1+N	C	101613	Ex9PN-N 1PN C3	1/12/144
4 A	1+N	C	101614	Ex9PN-N 1PN C4	1/12/144
6 A	1+N	C	101615	Ex9PN-N 1PN C6	1/12/144
10 A	1+N	C	101616	Ex9PN-N 1PN C10	1/12/144
13 A	1+N	C	102355	Ex9PN-N 1PN C13	1/12/144
16 A	1+N	C	101617	Ex9PN-N 1PN C16	1/12/144
20 A	1+N	C	101618	Ex9PN-N 1PN C20	1/12/144
25 A	1+N	C	101619	Ex9PN-N 1PN C25	1/12/144
32 A	1+N	C	101620	Ex9PN-N 1PN C32	1/12/144
40 A	1+N	C	101621	Ex9PN-N 1PN C40	1/12/144



DC Miniature Circuit Breakers Ex9BD



- General purpose DC Miniature Circuit Breakers
- Tested according to IEC / EN 60947-2
- Rated operating voltage U_n 220 V DC per pole
- Rated current 1 up to 63 A
- Rated short circuit breaking capacity I_{cu} 10 kA
- 1 and 2 pole versions
- Tripping characteristics C, K
- Wide range of accessories

General purpose DC Miniature Circuit Breakers Ex9BD are designed for general direct current applications. Due to their polarity dependence it is necessary to respect the polarity of the current.

For applications with varying polarity, as e.g. Photovoltaic, please use PV MCB line Ex9BP (see Catalogue of Photovoltaic Components).

Type Key

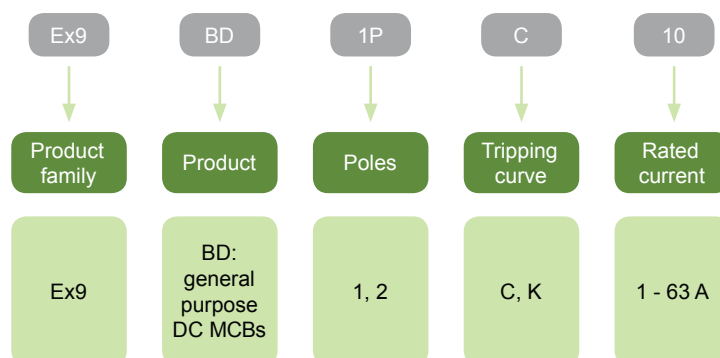

Certification marks



DC Miniature Circuit Breakers Ex9BD

Accessories



Auxiliary or signal contacts
AX, AL, AXL
Up to 3 units

Voltage or trip releases
SHT, UVT
Up to 2 units

MCB
Ex9BD
1, 2-module width

Auxiliary contacts AX3111, AX3122

see page 72

Alarm contact AL3111

see page 72

Auxiliary and alarm contact AXL31

see page 72

Shunt trip releases SHT31, SHT3111

see page 72

Undervoltage releases UVT31, UVT3101, UVT3110

see page 73

All accessories are mounted to the MCBs Ex9BD from the left side and are identical for devices of the line Ex9B and Ex9PN.

DC Miniature Circuit Breakers Ex9BD

C-Characteristic, 1-pole, 220 V DC



Rated current	Width	Char.	Article No.	Type	Packing
1 A	1 MU	C	103553	Ex9BD 1P C 1A	1/12/144
2 A	1 MU	C	103554	Ex9BD 1P C 2A	1/12/144
3 A	1 MU	C	103555	Ex9BD 1P C 3A	1/12/144
4 A	1 MU	C	103556	Ex9BD 1P C 4A	1/12/144
6 A	1 MU	C	103557	Ex9BD 1P C 6A	1/12/144
10 A	1 MU	C	103558	Ex9BD 1P C 10A	1/12/144
16 A	1 MU	C	103559	Ex9BD 1P C 16A	1/12/144
20 A	1 MU	C	103560	Ex9BD 1P C 20A	1/12/144
25 A	1 MU	C	103561	Ex9BD 1P C 25A	1/12/144
32 A	1 MU	C	103562	Ex9BD 1P C 32A	1/12/144
40 A	1 MU	C	103563	Ex9BD 1P C 40A	1/12/144
50 A	1 MU	C	103564	Ex9BD 1P C 50A	1/12/144
63 A	1 MU	C	103565	Ex9BD 1P C 63A	1/12/144

C-Characteristic, 2-pole, 440 V DC



Rated current	Width	Char.	Article No.	Type	Packing
1 A	2 MU	C	103566	Ex9BD 2P C 1A	1/6/72
2 A	2 MU	C	103567	Ex9BD 2P C 2A	1/6/72
3 A	2 MU	C	103568	Ex9BD 2P C 3A	1/6/72
4 A	2 MU	C	103569	Ex9BD 2P C 4A	1/6/72
6 A	2 MU	C	103570	Ex9BD 2P C 6A	1/6/72
10 A	2 MU	C	103571	Ex9BD 2P C 10A	1/6/72
16 A	2 MU	C	103572	Ex9BD 2P C 16A	1/6/72
20 A	2 MU	C	103573	Ex9BD 2P C 20A	1/6/72
25 A	2 MU	C	103574	Ex9BD 2P C 25A	1/6/72
32 A	2 MU	C	103575	Ex9BD 2P C 32A	1/6/72
40 A	2 MU	C	103576	Ex9BD 2P C 40A	1/6/72
50 A	2 MU	C	103577	Ex9BD 2P C 50A	1/6/72
63 A	2 MU	C	103578	Ex9BD 2P C 63A	1/6/72

DC Miniature Circuit Breakers Ex9BD

K-Characteristic, 1-pole, 220 V DC



Rated current	Width	Char.	Article No.	Type	Packing
1 A	1 MU	K	103605	Ex9BD 1P K 1A	1/12/144
2 A	1 MU	K	103606	Ex9BD 1P K 2A	1/12/144
3 A	1 MU	K	103607	Ex9BD 1P K 3A	1/12/144
4 A	1 MU	K	103608	Ex9BD 1P K 4A	1/12/144
6 A	1 MU	K	103609	Ex9BD 1P K 6A	1/12/144
10 A	1 MU	K	103610	Ex9BD 1P K 10A	1/12/144
16 A	1 MU	K	103611	Ex9BD 1P K 16A	1/12/144
20 A	1 MU	K	103612	Ex9BD 1P K 20A	1/12/144
25 A	1 MU	K	103613	Ex9BD 1P K 25A	1/12/144
32 A	1 MU	K	103614	Ex9BD 1P K 32A	1/12/144
40 A	1 MU	K	103615	Ex9BD 1P K 40A	1/12/144
50 A	1 MU	K	103616	Ex9BD 1P K 50A	1/12/144
63 A	1 MU	K	103617	Ex9BD 1P K 63A	1/12/144

K-Characteristic, 2-pole, 440 V DC



Rated current	Width	Char.	Article No.	Type	Packing
1 A	2 MU	K	103618	Ex9BD 2P K 1A	1/6/72
2 A	2 MU	K	103619	Ex9BD 2P K 2A	1/6/72
3 A	2 MU	K	103620	Ex9BD 2P K 3A	1/6/72
4 A	2 MU	K	103621	Ex9BD 2P K 4A	1/6/72
6 A	2 MU	K	103622	Ex9BD 2P K 6A	1/6/72
10 A	2 MU	K	103623	Ex9BD 2P K 10A	1/6/72
16 A	2 MU	K	103624	Ex9BD 2P K 16A	1/6/72
20 A	2 MU	K	103625	Ex9BD 2P K 20A	1/6/72
25 A	2 MU	K	103626	Ex9BD 2P K 25A	1/6/72
32 A	2 MU	K	103627	Ex9BD 2P K 32A	1/6/72
40 A	2 MU	K	103628	Ex9BD 2P K 40A	1/6/72
50 A	2 MU	K	103629	Ex9BD 2P K 50A	1/6/72
63 A	2 MU	K	103630	Ex9BD 2P K 63A	1/6/72

Isolators Ex9I125



- **Modular Isolators**
- **Rated current up to 125 A**
- **Rated voltage 230 / 400 V AC**
- **Rated short-time withstand current $I_{cw} = 12 \times I_e$, 1 s**
- **Meet requirements of IEC / EN 60947-3**
- **Built-in lock mechanism for OFF position**
- **1 up to 4-pole version**

Isolators Ex9I125 can be used as a main switch in wide variety of applications. These switches are tested according to IEC / EN 60947-3 standards and fulfill also requirements for isolation function.

Utilization category AC-22A ensures possibility of switching mixed resistive and inductive loads with low overloads with $\cos \varphi = 0.65$. Subcategory A allows frequent operation.

Isolators of line Ex9I125 are produced in modular design with width one module unit per pole. Can be connected via standard busbars of both fork as well as pin type of connection.

Type Key

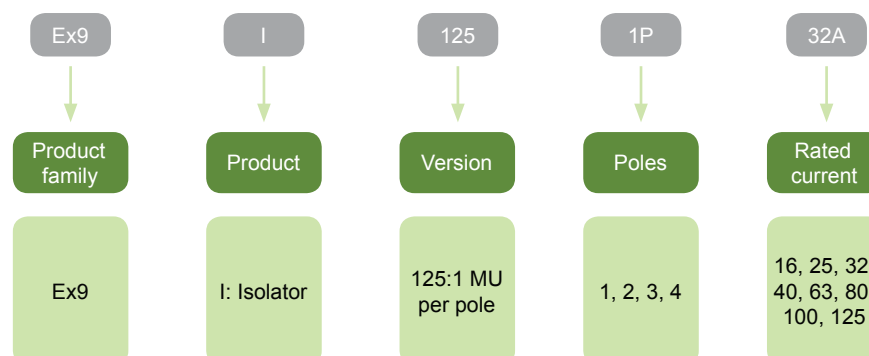

Certification marks



Isolators Ex91125

1-pole



Rated current	Poles	Width	Article No.	Type	Packing
16 A	1	1 MU	102304	Ex91125 1P 16A	1/12/144
25 A	1	1 MU	102305	Ex91125 1P 25A	1/12/144
32 A	1	1 MU	100862	Ex91125 1P 32A	1/12/144
40 A	1	1 MU	100863	Ex91125 1P 40A	1/12/144
63 A	1	1 MU	100864	Ex91125 1P 63A	1/12/144
80 A	1	1 MU	100865	Ex91125 1P 80A	1/12/144
100 A	1	1 MU	100866	Ex91125 1P 100A	1/12/144
125 A	1	1 MU	100867	Ex91125 1P 125A	1/12/144

2-pole



Rated current	Poles	Width	Article No.	Type	Packing
16 A	2	2 MU	102306	Ex91125 2P 16A	1/6/72
25 A	2	2 MU	102307	Ex91125 2P 25A	1/6/72
32 A	2	2 MU	100868	Ex91125 2P 32A	1/6/72
40 A	2	2 MU	100869	Ex91125 2P 40A	1/6/72
63 A	2	2 MU	100870	Ex91125 2P 63A	1/6/72
80 A	2	2 MU	100871	Ex91125 2P 80A	1/6/72
100 A	2	2 MU	100872	Ex91125 2P 100A	1/6/72
125 A	2	2 MU	100873	Ex91125 2P 125A	1/6/72

3-pole



Rated current	Poles	Width	Article No.	Type	Packing
16 A	3	3 MU	102308	Ex91125 3P 16A	1/4/48
25 A	3	3 MU	102309	Ex91125 3P 25A	1/4/48
32 A	3	3 MU	100874	Ex91125 3P 32A	1/4/48
40 A	3	3 MU	100875	Ex91125 3P 40A	1/4/48
63 A	3	3 MU	100876	Ex91125 3P 63A	1/4/48
80 A	3	3 MU	100877	Ex91125 3P 80A	1/4/48
100 A	3	3 MU	100878	Ex91125 3P 100A	1/4/48
125 A	3	3 MU	100879	Ex91125 3P 125A	1/4/48

4-pole



Rated current	Poles	Width	Article No.	Type	Packing
16 A	4	4 MU	102310	Ex91125 4P 16A	1/3/36
25 A	4	4 MU	102311	Ex91125 4P 25A	1/3/36
32 A	4	4 MU	100880	Ex91125 4P 32A	1/3/36
40 A	4	4 MU	100881	Ex91125 4P 40A	1/3/36
63 A	4	4 MU	100882	Ex91125 4P 63A	1/3/36
80 A	4	4 MU	100883	Ex91125 4P 80A	1/3/36
100 A	4	4 MU	100884	Ex91125 4P 100A	1/3/36
125 A	4	4 MU	100885	Ex91125 4P 125A	1/3/36

Isolators Ex9I40



- Modular Isolators
- Rated current up to 40 A
- Width 1 MU up to 4-pole version
- Rated voltage 230 / 400 V AC
- Rated short-time withstand current $I_{cw} = 12 \times I_e, 1 \text{ s}$
- Meet requirements of IEC / EN 60947-3
- Built-in lock mechanism for OFF position
- 1 up to 4-pole version

Isolators Ex9I40 can be used as a main switch in wide variety of applications. These switches are tested according to IEC / EN 60947-3 standards and fulfill also requirements for isolation function.

Utilization category AC-22A ensures possibility of switching mixed resistive and inductive loads with low overloads with $\cos \varphi = 0.65$. Subcategory A allows frequent operation.

Isolators of line Ex9I40 are produced in modular design with width one module unit for all versions up to 4-pole. It brings very low consumption of space in an installation.

Type Key

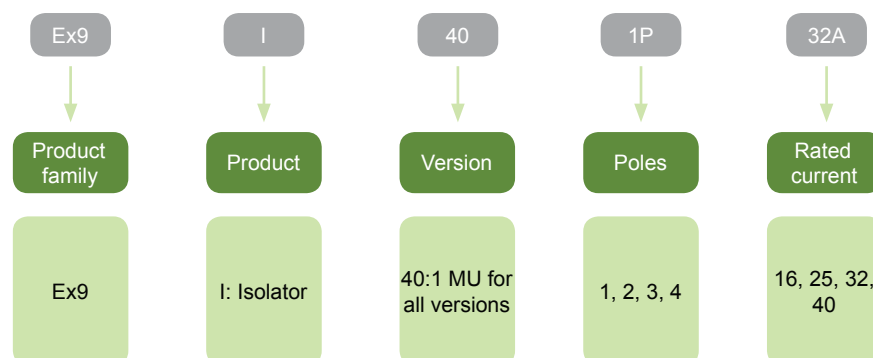

Certification marks



Isolators Ex9I40

1-pole



Rated current	Poles	Width	Article No.	Type	Packing
16 A	1	1 MU	102296	Ex9I40 1P 16A	1/12/144
25 A	1	1 MU	102297	Ex9I40 1P 25A	1/12/144
32 A	1	1 MU	101387	Ex9I40 1P 32A	1/12/144
40 A	1	1 MU	101388	Ex9I40 1P 40A	1/12/144

2-pole



Rated current	Poles	Width	Article No.	Type	Packing
16 A	2	1 MU	102298	Ex9I40 2P 16A	1/12/144
25 A	2	1 MU	102299	Ex9I40 2P 25A	1/12/144
32 A	2	1 MU	101389	Ex9I40 2P 32A	1/12/144
40 A	2	1 MU	101390	Ex9I40 2P 40A	1/12/144

3-pole



Rated current	Poles	Width	Article No.	Type	Packing
16 A	3	1 MU	102300	Ex9I40 3P 16A	1/12/144
25 A	3	1 MU	102301	Ex9I40 3P 25A	1/12/144
32 A	3	1 MU	101391	Ex9I40 3P 32A	1/12/144
40 A	3	1 MU	101392	Ex9I40 3P 40A	1/12/144

4-pole



Rated current	Poles	Width	Article No.	Type	Packing
16 A	4	1 MU	102302	Ex9I40 4P 16A	1/12/144
25 A	4	1 MU	102303	Ex9I40 4P 25A	1/12/144
32 A	4	1 MU	101393	Ex9I40 4P 32A	1/12/144
40 A	4	1 MU	101394	Ex9I40 4P 40A	1/12/144

Isolators Ex9BI



- **Modular Isolators**
- **Wide range of accessories**
- **Rated current up to 63 A**
- **Rated voltage 230 / 400 V AC**
- **Rated short-time withstand current $I_{cw} = 1 \text{ kA}, 1 \text{ s}$**
- **Meet requirements of IEC / EN 60947-3**
- **1 up to 4-pole version**

Isolators Ex9BI can be used as a main switch in wide variety of applications. These switches are tested according to IEC / EN 60947-3 standards and fulfill also requirements for isolation function.

Utilization category AC-22A ensures possibility of switching mixed resistive and inductive loads with low overloads with $\cos \varphi = 0.65$. Subcategory A allows frequent operation.

Isolators of line Ex9BI are produced in modular design with width one module unit per pole. Can be connected via standard busbars of both fork as well as pin type of connection.

Ex9BI Isolators can be also combined with wide range of accessories including auxiliary contacts, shunt trip releases, undervoltage and overvoltage releases. It is possible to create diversified combination of accessories.

Type Key

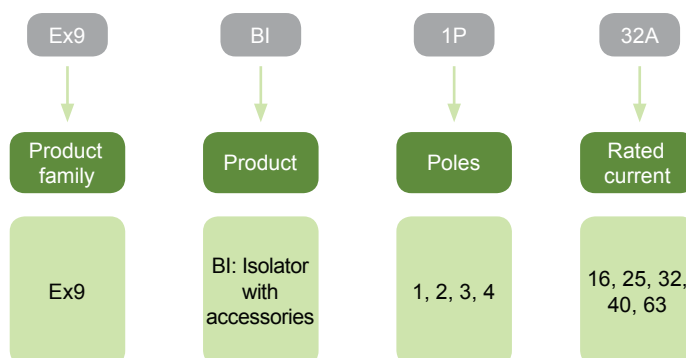

Certification marks



Isolators Ex9BI

Accessories



Auxiliary contacts
AX
Up to 3 units

Voltage or trip releases
SHT, UVT, OVT
Up to 2 units

Isolator
Ex9BI
1, 2, 3, 4-pole

Auxiliary contacts AX3111, AX3122

see page 72

Shunt trip releases SHT31, SHT3111

see page 72

Undervoltage releases UVT31, UVT3101, UVT3110

see page 73

Oversvoltage release OVT31

see page 73

All accessories are mounted from the left side and are identical for devices of the line Ex9B and Ex9PN.

Isolators Ex9BI

1-pole



Rated current	Poles	Width	Article No.	Type	Packing
16 A	1	1 MU	102378	Ex9BI 1P 16A	1/12/144
25 A	1	1 MU	102379	Ex9BI 1P 25A	1/12/144
32 A	1	1 MU	102380	Ex9BI 1P 32A	1/12/144
40 A	1	1 MU	102381	Ex9BI 1P 40A	1/12/144
63 A	1	1 MU	102382	Ex9BI 1P 63A	1/12/144

2-pole



Rated current	Poles	Width	Article No.	Type	Packing
16 A	2	2 MU	102383	Ex9BI 2P 16A	1/6/72
25 A	2	2 MU	102384	Ex9BI 2P 25A	1/6/72
32 A	2	2 MU	102385	Ex9BI 2P 32A	1/6/72
40 A	2	2 MU	102386	Ex9BI 2P 40A	1/6/72
63 A	2	2 MU	102387	Ex9BI 2P 63A	1/6/72

3-pole



Rated current	Poles	Width	Article No.	Type	Packing
16 A	3	3 MU	102388	Ex9BI 3P 16A	1/4/48
25 A	3	3 MU	102389	Ex9BI 3P 25A	1/4/48
32 A	3	3 MU	102390	Ex9BI 3P 32A	1/4/48
40 A	3	3 MU	102391	Ex9BI 3P 40A	1/4/48
63 A	3	3 MU	102392	Ex9BI 3P 63A	1/4/48

4-pole



Rated current	Poles	Width	Article No.	Type	Packing
16 A	4	4 MU	102393	Ex9BI 4P 16A	1/3/36
25 A	4	4 MU	102394	Ex9BI 4P 25A	1/3/36
32 A	4	4 MU	102395	Ex9BI 4P 32A	1/3/36
40 A	4	4 MU	102396	Ex9BI 4P 40A	1/3/36
63 A	4	4 MU	102397	Ex9BI 4P 63A	1/3/36



RCCBs Ex9CL-H/-100, 10 kA



- Residual Current Circuit Breakers according to IEC / EN 61008-1
- Conditional rated short circuit strength / I_{nc} 10 kA
- 2 and 4-pole versions
- Rated residual current 30, 100, 300 mA
- Rated current up to 100 A
- Rated operational voltage 230/400 V AC
- AC, A, S and S+A types
- Signaling of electrical tripping

Ex9CL-H and Ex9CL-100 residual current circuit breakers are suitable for domestic as well as industrial applications. They are based on permanent magnet principle. It brings the advantage of Voltage independent function. Adequate voltage is only necessary when testing of the RCCB with the T test button. Magnetic RCCBs should be tested regularly with a period of one month.

Type Key

Ex9	CL	-H	2P	63 A	A	30mA	S
↓	↓	↓	↓	↓	↓	↓	↓
Product family	Product	Conditional short circuit strength	Poles	Rated current	Sensitivity to type of current	Rated residual current	Time delay (insensitivity)
Ex9	CL: RCCB	-H: 10 kA (63A case) -100: 10 kA (100A case)	2, 4	25, 40, 63, 80, 100 A	_ : AC A : A	30, 100, 300 mA	_ : 0 ms (63A case) S : 40 ms (100A case)

Certification marks



RCCBs Ex9CL-H, 10 kA

AC type, 2-pole

- AC type of residual current circuit breaker sensitive on residual AC current
- Without time delay
- Surge current-proof 250 A
- 30 mA version suitable for protection of people in case of direct and indirect contact with live parts and exposed conductive part during a fault, respectively
- Selective with upstream installed S or S+A type RCCB



Rated current	Rated residual current	Poles	Article No.	Type	Packing
25 A	30 mA	2	100643	Ex9CL-H 2P 25A 30mA	1/81
40 A	30 mA	2	100646	Ex9CL-H 2P 40A 30mA	1/81
63 A	30 mA	2	100649	Ex9CL-H 2P 63A 30mA	1/81
25 A	100 mA	2	100644	Ex9CL-H 2P 25A 100mA	1/81
40 A	100 mA	2	100647	Ex9CL-H 2P 40A 100mA	1/81
63 A	100 mA	2	100650	Ex9CL-H 2P 63A 100mA	1/81
25 A	300 mA	2	100645	Ex9CL-H 2P 25A 300mA	1/81
40 A	300 mA	2	100648	Ex9CL-H 2P 40A 300mA	1/81
63 A	300 mA	2	100651	Ex9CL-H 2P 63A 300mA	1/81

Wiring diagram

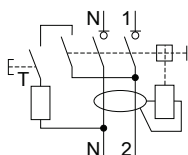

AC type, 4-pole

- AC type of residual current circuit breaker sensitive on residual AC current
- Without time delay
- Surge current-proof 250 A
- 30 mA version suitable for protection of people in case of direct and indirect contact with live parts and exposed conductive part during a fault, respectively
- Selective with upstream installed S or S+A type RCCB



Rated current	Rated residual current	Poles	Article No.	Type	Packing
25 A	30 mA	4	100652	Ex9CL-H 4P 25A 30mA	1/45
40 A	30 mA	4	100655	Ex9CL-H 4P 40A 30mA	1/45
63 A	30 mA	4	100658	Ex9CL-H 4P 63A 30mA	1/45
25 A	100 mA	4	100653	Ex9CL-H 4P 25A 100mA	1/45
40 A	100 mA	4	100656	Ex9CL-H 4P 40A 100mA	1/45
63 A	100 mA	4	100659	Ex9CL-H 4P 63A 100mA	1/45
25 A	300 mA	4	100654	Ex9CL-H 4P 25A 300mA	1/45
40 A	300 mA	4	100657	Ex9CL-H 4P 40A 300mA	1/45
63 A	300 mA	4	100660	Ex9CL-H 4P 63A 300mA	1/45

Wiring diagram

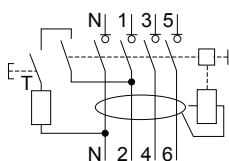

RCCBs Ex9CL-H, 10 kA

A type, 2-pole

- A type of residual current circuit breaker sensitive on residual AC and pulsating DC current
- Without time delay
- Surge current-proof 250 A
- 30 mA version suitable for protection of people in case of direct and indirect contact with live parts and exposed conductive part during a fault, respectively
- Selective with upstream installed S or S+A type RCCB



Rated current	Rated residual current	Poles	Article No.	Type	Packing
25 A	30 mA	2	100661	Ex9CL-H 2P 25A A 30mA	1/81
40 A	30 mA	2	100664	Ex9CL-H 2P 40A A 30mA	1/81
63 A	30 mA	2	100667	Ex9CL-H 2P 63A A 30mA	1/81
25 A	100 mA	2	100662	Ex9CL-H 2P 25A A 100mA	1/81
40 A	100 mA	2	100665	Ex9CL-H 2P 40A A 100mA	1/81
63 A	100 mA	2	100668	Ex9CL-H 2P 63A A 100mA	1/81
25 A	300 mA	2	100663	Ex9CL-H 2P 25A A 300mA	1/81
40 A	300 mA	2	100666	Ex9CL-H 2P 40A A 300mA	1/81
63 A	300 mA	2	100669	Ex9CL-H 2P 63A A 300mA	1/81

Wiring diagram

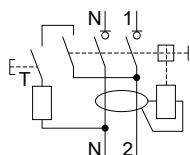

A type, 4-pole

- A type of residual current circuit breaker sensitive on residual AC and pulsating DC current
- Without time delay
- Surge current-proof 250 A
- 30 mA version suitable for protection of people in case of direct and indirect contact with live parts and exposed conductive part during a fault, respectively
- Selective with upstream installed S or S+A type RCCB



Rated current	Rated residual current	Poles	Article No.	Type	Packing
25 A	30 mA	4	100670	Ex9CL-H 4P 25A A 30mA	1/45
40 A	30 mA	4	100673	Ex9CL-H 4P 40A A 30mA	1/45
63 A	30 mA	4	100676	Ex9CL-H 4P 63A A 30mA	1/45
25 A	100 mA	4	100671	Ex9CL-H 4P 25A A 100mA	1/45
40 A	100 mA	4	100674	Ex9CL-H 4P 40A A 100mA	1/45
63 A	100 mA	4	100677	Ex9CL-H 4P 63A A 100mA	1/45
25 A	300 mA	4	100672	Ex9CL-H 4P 25A A 300mA	1/45
40 A	300 mA	4	100675	Ex9CL-H 4P 40A A 300mA	1/45
63 A	300 mA	4	100678	Ex9CL-H 4P 63A A 300mA	1/45

Wiring diagram

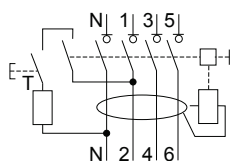

RCCBs Ex9CL-100, 10 kA

S type, 2-pole

- S type of residual current circuit breaker based on AC type sensitive on residual AC current
- With time delay (insensitivity) 40 ms
- Surge current-proof 3000 A
- Suitable for protection against fire, as a main RCCB of a house or flat or as a protection against leakage currents (e.g. due to imperfect isolation)
- Selective with downstream installed AC or A type RCCB



Rated current	Rated residual current	Poles	Article No.	Type	Packing
63 A	100 mA	2	100715	Ex9CL-100 2P 63A 100mA S	1/81
80 A	100 mA	2	100717	Ex9CL-100 2P 80A 100mA S	1/81
100 A	100 mA	2	100719	Ex9CL-100 2P 100A 100mA S	1/81
63 A	300 mA	2	100716	Ex9CL-100 2P 63A 300mA S	1/81
80 A	300 mA	2	100718	Ex9CL-100 2P 80A 300mA S	1/81
100 A	300 mA	2	100720	Ex9CL-100 2P 100A 300mA S	1/81

Wiring diagram

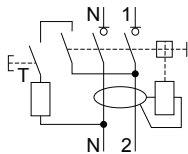

S type, 4-pole

- S type of residual current circuit breaker based on AC type sensitive on residual AC current
- With time delay (insensitivity) 40 ms
- Surge current-proof 3000 A
- Suitable for protection against fire, as a main RCCB of a house or flat or as a protection against leakage currents (e.g. due to imperfect isolation)
- Selective with downstream installed AC or A type RCCB



Rated current	Rated residual current	Poles	Article No.	Type	Packing
63 A	100 mA	4	100721	Ex9CL-100 4P 63A 100mA S	1/45
80 A	100 mA	4	100723	Ex9CL-100 4P 80A 100mA S	1/45
100 A	100 mA	4	100725	Ex9CL-100 4P 100A 100mA S	1/45
63 A	300 mA	4	100722	Ex9CL-100 4P 63A 300mA S	1/45
80 A	300 mA	4	100724	Ex9CL-100 4P 80A 300mA S	1/45
100 A	300 mA	4	100726	Ex9CL-100 4P 100A 300mA S	1/45

Wiring diagram

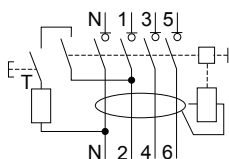

RCCBs Ex9CL-100, 10 kA

S+A type, 2-pole

- S type of residual current circuit breaker based on A type sensitive on residual AC and pulsating DC current
- With time delay (insensitivity) 40 ms
- Surge current-proof 3000 A
- Suitable for protection against fire, as a main RCCB of a house or flat or as a protection against leakage currents (e.g. due to imperfect isolation)
- Selective with downstream installed AC or A type RCCB



Rated current	Rated residual current	Poles	Article No.	Type	Packing
63 A	100 mA	2	100727	Ex9CL-100 2P 63A A 100mA S	1/81
80 A	100 mA	2	100729	Ex9CL-100 2P 80A A 100mA S	1/81
100 A	100 mA	2	100731	Ex9CL-100 2P 100A A 100mA S	1/81
63 A	300 mA	2	100728	Ex9CL-100 2P 63A A 300mA S	1/81
80 A	300 mA	2	100730	Ex9CL-100 2P 80A A 300mA S	1/81
100 A	300 mA	2	100732	Ex9CL-100 2P 100A A 300mA S	1/81

Wiring diagram

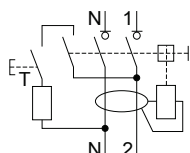

S+A type, 4-pole

- S type of residual current circuit breaker based on A type sensitive on residual AC and pulsating DC current
- With time delay (insensitivity) 40 ms
- Surge current-proof 3000 A
- Suitable for protection against fire, as a main RCCB of a house or flat or as a protection against leakage currents (e.g. due to imperfect isolation)
- Selective with downstream installed AC or A type RCCB



Rated current	Rated residual current	Poles	Article No.	Type	Packing
63 A	100 mA	4	100733	Ex9CL-100 4P 63A A 100mA S	1/45
80 A	100 mA	4	100735	Ex9CL-100 4P 80A A 100mA S	1/45
100 A	100 mA	4	100737	Ex9CL-100 4P 100A A 100mA S	1/45
63 A	300 mA	4	100734	Ex9CL-100 4P 63A A 300mA S	1/45
80 A	300 mA	4	100736	Ex9CL-100 4P 80A A 300mA S	1/45
100 A	300 mA	4	100738	Ex9CL-100 4P 100A A 300mA S	1/45

Wiring diagram

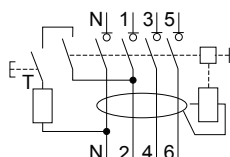

RCCBs Ex9CL-H/-100, 10 kA

Information sticker

- Sticker with information about regular monthly testing
- Languages EN, CZ, SK, FR, RU, PL, DE, RO
- In a scope of delivery of all magnetic RCCBs and RCBOs NOARK, spare part

Description	Languages	Article No.	Type	Packing
Information sticker	EN, CZ, SK, FR, RU, PL, DE, RO	101445	YS31	1

RCCBs Ex9CL-N, 6 kA



- Residual Current Circuit Breakers according to IEC / EN 61008-1
- Conditional rated short circuit strength I_{nc} 6 kA
- 2 and 4-pole versions
- Rated residual current 30, 300 mA
- Rated current up to 63 A
- Rated operational voltage 230/400 V AC
- AC type
- Signaling of electrical tripping

Ex9CL-N residual current circuit breakers are suitable mainly for domestic applications. They are based on permanent magnet principle. It brings the advantage of Voltage independent function. Adequate voltage is only necessary when testing of the RCCB with the T test button. Magnetic RCCBs should be tested regularly with a period of one month.

6 kA variant of the Ex9CL-N residual current circuit breaker is intended mainly for low demanding application like basic protection in household installations.

Type Key

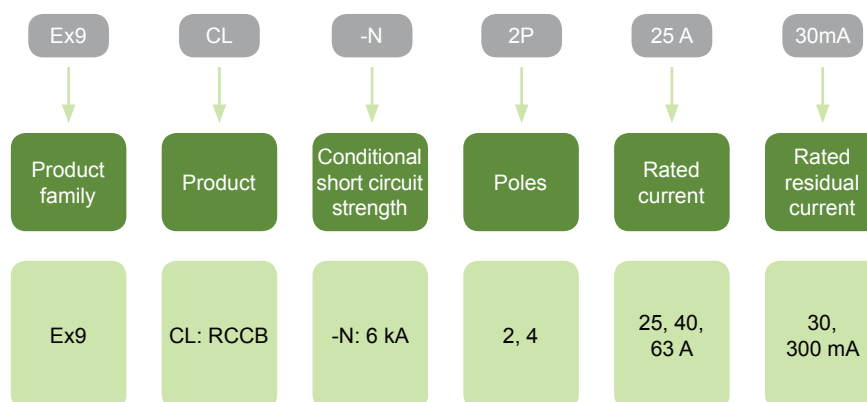

Certification marks



RCCBs Ex9CL-N, 6 kA

AC type, 2-pole

- AC type of residual current circuit breaker sensitive on residual AC current
- Without time delay
- Surge current-proof 250 A
- 30 mA version suitable for protection of people in case of direct and indirect contact with live parts and exposed conductive part during a fault, respectively
- Selective with upstream installed S or S+A type RCCB



Rated current	Rated residual current	Poles	Article No.	Type	Packing
25 A	30 mA	2	100607	Ex9CL-N 2P 25A 30mA	1/81
40 A	30 mA	2	100610	Ex9CL-N 2P 40A 30mA	1/81
40 A	300 mA	2	100612	Ex9CL-N 2P 40A 300mA	1/81

Wiring diagram

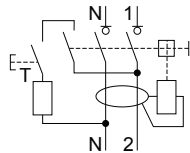

AC type, 4-pole

- AC type of residual current circuit breaker sensitive on residual AC current
- Without time delay
- Surge current-proof 250 A
- 30 mA version suitable for protection of people in case of direct and indirect contact with live parts and exposed conductive part during a fault, respectively
- Selective with upstream installed S or S+A type RCCB



Rated current	Rated residual current	Poles	Article No.	Type	Packing
25 A	30 mA	4	100616	Ex9CL-N 4P 25A 30mA	1/45
40 A	30 mA	4	100619	Ex9CL-N 4P 40A 30mA	1/45
63 A	30 mA	4	100622	Ex9CL-N 4P 63A 30mA	1/45
40 A	300 mA	4	100621	Ex9CL-N 4P 40A 300mA	1/45
63 A	300 mA	4	100624	Ex9CL-N 4P 63A 300mA	1/45

Wiring diagram

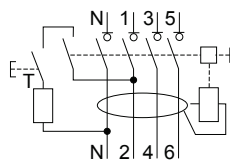

Information sticker

- Sticker with information about regular monthly testing
- Languages EN, CZ, SK, FR, RU, PL, DE, RO
- In a scope of delivery of all magnetic RCCBs and RCBOs NOARK, spare part

Description	Languages	Article No.	Type	Packing
Information sticker	EN, CZ, SK, FR, RU, PL, DE, RO	101445	YS31	1

RCBOs Ex9CBL-H, 10 kA



- Residual Current Breakers with Overload protection according to IEC / EN 61009
- Rated breaking capacity I_{cn} 10 kA
- 1+N-pole version
- Rated residual current 30, 100, 300 mA
- Rated currents up to 40 A
- Rated operational voltage 230 V AC
- Tripping characteristics of installed circuit breaker B and C
- AC and A type of RCD
- 2-module width

Ex9CBL residual current circuit breakers are suitable for domestic as well as industrial applications. They are based on combination of residual current device with permanent magnet principle and circuit breaker with thermal overload release and magnetic short circuit current release. It brings the advantage of Voltage independent function of the residual current device. Adequate voltage is only necessary when testing of the RCD with the T test button. Magnetic RCDs should be tested regularly with a period of one month.

Type Key

Ex9	CBL	-H	1P+N	B	16	A	30 mA
↓	↓	↓	↓	↓	↓	↓	↓
Product family	Product	Rated breaking capacity	Poles	Tripping char. of MCB	Rated current	Sensitivity to type of current	Rated residual current
Ex9	CBL: RCBO	-H : 10 kA	1+N	B, C	6 — 40 A	_ : AC A : A	30 mA 100 mA 300 mA

Certification marks



RCBOs Ex9CBL-H, 10 kA

Accessories



Voltage or trip releases
SHTC, UVTC
Up to 2 units

RCBO
Ex9CBL
1+N-pole

Shunt trip releases SHTC31
Undervoltage release UVTC31

see page 76
see page 76

All accessories are mounted to the Ex9CBL devices from the left side.

RCBOs Ex9CBL-H, 10 kA

AC type, characteristic B

- AC type of residual current circuit breaker sensitive on residual AC current
- B characteristic of installed circuit breaker
- Without time delay
- Surge current-proof 250 A
- Suitable for protection of people in case of direct and indirect contact with live parts and exposed conductive part during a fault, respectively
- Selective with upstream installed S or S+A type RCCB



Rated current	Rated residual current	MCB tripping char.	Article No.	Type	Packing
6 A	30 mA	B	100771	Ex9CBL-H 1P+N B6 30mA	1/81
10 A	30 mA	B	100772	Ex9CBL-H 1P+N B10 30mA	1/81
13 A	30 mA	B	100773	Ex9CBL-H 1P+N B13 30mA	1/81
16 A	30 mA	B	100774	Ex9CBL-H 1P+N B16 30mA	1/81
20 A	30 mA	B	100775	Ex9CBL-H 1P+N B20 30mA	1/81
25 A	30 mA	B	100776	Ex9CBL-H 1P+N B25 30mA	1/81
32 A	30 mA	B	100777	Ex9CBL-H 1P+N B32 30mA	1/81
40 A	30 mA	B	100778	Ex9CBL-H 1P+N B40 30mA	1/81
6 A	100 mA	B	103266	Ex9CBL-H 1P+N B6 100mA	1/81
10 A	100 mA	B	103267	Ex9CBL-H 1P+N B10 100mA	1/81
13 A	100 mA	B	103268	Ex9CBL-H 1P+N B13 100mA	1/81
16 A	100 mA	B	103269	Ex9CBL-H 1P+N B16 100mA	1/81
20 A	100 mA	B	103270	Ex9CBL-H 1P+N B20 100mA	1/81
25 A	100 mA	B	103271	Ex9CBL-H 1P+N B25 100mA	1/81
32 A	100 mA	B	103272	Ex9CBL-H 1P+N B32 100mA	1/81
40 A	100 mA	B	103273	Ex9CBL-H 1P+N B40 100mA	1/81
6 A	300 mA	B	103274	Ex9CBL-H 1P+N B6 300mA	1/81
10 A	300 mA	B	103275	Ex9CBL-H 1P+N B10 300mA	1/81
13 A	300 mA	B	103276	Ex9CBL-H 1P+N B13 300mA	1/81
16 A	300 mA	B	103277	Ex9CBL-H 1P+N B16 300mA	1/81
20 A	300 mA	B	103278	Ex9CBL-H 1P+N B20 300mA	1/81
25 A	300 mA	B	103279	Ex9CBL-H 1P+N B25 300mA	1/81
32 A	300 mA	B	103280	Ex9CBL-H 1P+N B32 300mA	1/81
40 A	300 mA	B	103281	Ex9CBL-H 1P+N B40 300mA	1/81

Wiring diagram

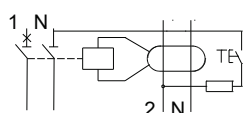

RCBOs Ex9CBL-H, 10 kA

AC type, characteristic C

- AC type of residual current circuit breaker sensitive on residual AC current
- C characteristic of installed circuit breaker
- Without time delay
- Surge current-proof 250 A
- Suitable for protection of people in case of direct and indirect contact with live parts and exposed conductive part during a fault, respectively
- Selective with upstream installed S or S+A type RCCB



Rated current	Rated residual current	MCB tripping char.	Article No.	Type	Packing
6 A	30 mA	C	100779	Ex9CBL-H 1P+N C6 30mA	1/81
10 A	30 mA	C	100780	Ex9CBL-H 1P+N C10 30mA	1/81
13 A	30 mA	C	100781	Ex9CBL-H 1P+N C13 30mA	1/81
16 A	30 mA	C	100782	Ex9CBL-H 1P+N C16 30mA	1/81
20 A	30 mA	C	100783	Ex9CBL-H 1P+N C20 30mA	1/81
25 A	30 mA	C	100784	Ex9CBL-H 1P+N C25 30mA	1/81
32 A	30 mA	C	100785	Ex9CBL-H 1P+N C32 30mA	1/81
40 A	30 mA	C	100786	Ex9CBL-H 1P+N C40 30mA	1/81
6 A	100 mA	C	103282	Ex9CBL-H 1P+N C6 100mA	1/81
10 A	100 mA	C	103283	Ex9CBL-H 1P+N C10 100mA	1/81
13 A	100 mA	C	103284	Ex9CBL-H 1P+N C13 100mA	1/81
16 A	100 mA	C	103285	Ex9CBL-H 1P+N C16 100mA	1/81
20 A	100 mA	C	103286	Ex9CBL-H 1P+N C20 100mA	1/81
25 A	100 mA	C	103287	Ex9CBL-H 1P+N C25 100mA	1/81
32 A	100 mA	C	103288	Ex9CBL-H 1P+N C32 100mA	1/81
40 A	100 mA	C	103289	Ex9CBL-H 1P+N C40 100mA	1/81
6 A	300 mA	C	103290	Ex9CBL-H 1P+N C6 300mA	1/81
10 A	300 mA	C	103291	Ex9CBL-H 1P+N C10 300mA	1/81
13 A	300 mA	C	103292	Ex9CBL-H 1P+N C13 300mA	1/81
16 A	300 mA	C	103293	Ex9CBL-H 1P+N C16 300mA	1/81
20 A	300 mA	C	103294	Ex9CBL-H 1P+N C20 300mA	1/81
25 A	300 mA	C	103295	Ex9CBL-H 1P+N C25 300mA	1/81
32 A	300 mA	C	103296	Ex9CBL-H 1P+N C32 300mA	1/81
40 A	300 mA	C	103297	Ex9CBL-H 1P+N C40 300mA	1/81

Wiring diagram

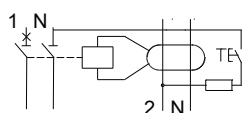

RCBOs Ex9CBL-H, 10 kA

A type, characteristic B

- A type of residual current circuit breaker sensitive on residual AC and pulsating DC current
- B characteristic of installed circuit breaker
- Without time delay
- Surge current-proof 250 A
- Suitable for protection of people in case of direct and indirect contact with live parts and exposed conductive part during a fault, respectively
- Selective with upstream installed S or S+A type RCCB



Rated current	Rated residual current	MCB tripping char.	Article No.	Type	Packing
6 A	30 mA	B	100787	Ex9CBL-H 1P+N B6 A 30mA	1/81
10 A	30 mA	B	100788	Ex9CBL-H 1P+N B10 A 30mA	1/81
13 A	30 mA	B	100789	Ex9CBL-H 1P+N B13 A 30mA	1/81
16 A	30 mA	B	100790	Ex9CBL-H 1P+N B16 A 30mA	1/81
20 A	30 mA	B	100791	Ex9CBL-H 1P+N B20 A 30mA	1/81
25 A	30 mA	B	100792	Ex9CBL-H 1P+N B25 A 30mA	1/81
32 A	30 mA	B	100793	Ex9CBL-H 1P+N B32 A 30mA	1/81
40 A	30 mA	B	100794	Ex9CBL-H 1P+N B40 A 30mA	1/81
6 A	100 mA	B	103298	Ex9CBL-H 1P+N B6 A 100mA	1/81
10 A	100 mA	B	103299	Ex9CBL-H 1P+N B10 A 100mA	1/81
13 A	100 mA	B	103300	Ex9CBL-H 1P+N B13 A 100mA	1/81
16 A	100 mA	B	103301	Ex9CBL-H 1P+N B16 A 100mA	1/81
20 A	100 mA	B	103302	Ex9CBL-H 1P+N B20 A 100mA	1/81
25 A	100 mA	B	103303	Ex9CBL-H 1P+N B25 A 100mA	1/81
32 A	100 mA	B	103304	Ex9CBL-H 1P+N B32 A 100mA	1/81
40 A	100 mA	B	103305	Ex9CBL-H 1P+N B40 A 100mA	1/81
6 A	300 mA	B	103306	Ex9CBL-H 1P+N B6 A 300mA	1/81
10 A	300 mA	B	103307	Ex9CBL-H 1P+N B10 A 300mA	1/81
13 A	300 mA	B	103308	Ex9CBL-H 1P+N B13 A 300mA	1/81
16 A	300 mA	B	103309	Ex9CBL-H 1P+N B16 A 300mA	1/81
20 A	300 mA	B	103310	Ex9CBL-H 1P+N B20 A 300mA	1/81
25 A	300 mA	B	103311	Ex9CBL-H 1P+N B25 A 300mA	1/81
32 A	300 mA	B	103312	Ex9CBL-H 1P+N B32 A 300mA	1/81
40 A	300 mA	B	103313	Ex9CBL-H 1P+N B40 A 300mA	1/81

Wiring diagram

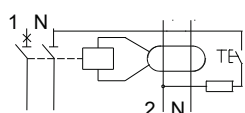

RCBOs Ex9CBL-H, 10 kA

A type, characteristic C

- A type of residual current circuit breaker sensitive on residual AC and pulsating DC current
- C characteristic of installed circuit breaker
- Without time delay
- Surge current-proof 250 A
- Suitable for protection of people in case of direct and indirect contact with live parts and exposed conductive part during a fault, respectively
- Selective with upstream installed S or S+A type RCCB



Rated current	Rated residual current	MCB tripping char.	Article No.	Type	Packing
6 A	30 mA	C	100795	Ex9CBL-H 1P+N C6 A 30mA	1/81
10 A	30 mA	C	100796	Ex9CBL-H 1P+N C10 A 30mA	1/81
13 A	30 mA	C	100797	Ex9CBL-H 1P+N C13 A 30mA	1/81
16 A	30 mA	C	100798	Ex9CBL-H 1P+N C16 A 30mA	1/81
20 A	30 mA	C	100799	Ex9CBL-H 1P+N C20 A 30mA	1/81
25 A	30 mA	C	100800	Ex9CBL-H 1P+N C25 A 30mA	1/81
32 A	30 mA	C	100801	Ex9CBL-H 1P+N C32 A 30mA	1/81
40 A	30 mA	C	100802	Ex9CBL-H 1P+N C40 A 30mA	1/81
6 A	100 mA	C	103314	Ex9CBL-H 1P+N C6 A 30mA	1/81
10 A	100 mA	C	103315	Ex9CBL-H 1P+N C10 A 30mA	1/81
13 A	100 mA	C	103316	Ex9CBL-H 1P+N C13 A 30mA	1/81
16 A	100 mA	C	103317	Ex9CBL-H 1P+N C16 A 30mA	1/81
20 A	100 mA	C	103318	Ex9CBL-H 1P+N C20 A 30mA	1/81
25 A	100 mA	C	103319	Ex9CBL-H 1P+N C25 A 30mA	1/81
32 A	100 mA	C	103320	Ex9CBL-H 1P+N C32 A 30mA	1/81
40 A	100 mA	C	103321	Ex9CBL-H 1P+N C40 A 30mA	1/81
6 A	300 mA	C	103322	Ex9CBL-H 1P+N C6 A 30mA	1/81
10 A	300 mA	C	103323	Ex9CBL-H 1P+N C10 A 30mA	1/81
13 A	300 mA	C	103324	Ex9CBL-H 1P+N C13 A 30mA	1/81
16 A	300 mA	C	103325	Ex9CBL-H 1P+N C16 A 30mA	1/81
20 A	300 mA	C	103326	Ex9CBL-H 1P+N C20 A 30mA	1/81
25 A	300 mA	C	103327	Ex9CBL-H 1P+N C25 A 30mA	1/81
32 A	300 mA	C	103328	Ex9CBL-H 1P+N C32 A 30mA	1/81
40 A	300 mA	C	103329	Ex9CBL-H 1P+N C40 A 30mA	1/81

Wiring diagram

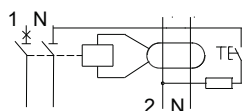

Information sticker

- Sticker with information about regular monthly testing
- Languages EN, CZ, SK, FR, RU, PL, DE, RO
- In a scope of delivery of all magnetic RCCBs and RCBOs NOARK, spare part

Description	Languages	Article No.	Type	Packing
Information sticker	EN, CZ, SK, FR, RU, PL, DE, RO	101445	YS31	1

RCBOs Ex9CBL-N, 6 kA



- Residual Current Breakers with Overload protection according to IEC / EN 61009
- Rated breaking capacity I_{cn} 6 kA
- 1+N-pole version
- Rated residual current 30, 100, 300 mA
- Rated currents up to 40 A
- Rated operational voltage 230 V AC
- Tripping characteristics of installed circuit breaker B and C
- AC and A type of RCD
- 2-module width

Ex9CBL residual current circuit breakers are suitable for domestic as well as industrial applications. They are based on combination of residual current device with permanent magnet principle and circuit breaker with thermal overload release and magnetic short circuit current release. It brings the advantage of Voltage independent function of the residual current device. Adequate voltage is only necessary when testing of the RCD with the T test button. Magnetic RCDs should be tested regularly with a period of one month.

Type Key

Ex9	CBL	-N	1P+N	B	16	A	30 mA
↓	↓	↓	↓	↓	↓	↓	↓
Product family	Product	Rated breaking capacity	Poles	Tripping char. of MCB	Rated current	Sensitivity to type of current	Rated residual current
Ex9	CBL: RCBO	-N : 6 kA	1+N	B, C	6 — 40 A	_ : AC A : A	30 mA 100 mA 300 mA

Certification marks



RCBOs Ex9CBL-N, 6 kA

Accessories



Voltage or trip releases
SHTC, UVTC
Up to 2 units

RCBO
Ex9CBL
1+N-pole

Shunt trip releases SHTC31
Undervoltage release UVTC31

see page 76
see page 76

All accessories are mounted to the Ex9CBL devices from the left side.

RCBOs Ex9CBL-N, 6 kA

AC type, characteristic B

- AC type of residual current circuit breaker sensitive on residual AC current
- B characteristic of installed circuit breaker
- Without time delay
- Surge current-proof 250 A
- Suitable for protection of people in case of direct and indirect contact with live parts and exposed conductive part during a fault, respectively
- Selective with upstream installed S or S+A type RCCB



Rated current	Rated residual current	MCB tripping char.	Article No.	Type	Packing
6 A	30 mA	B	100739	Ex9CBL-N 1P+N B6 30mA	1/81
10 A	30 mA	B	100740	Ex9CBL-N 1P+N B10 30mA	1/81
13 A	30 mA	B	100741	Ex9CBL-N 1P+N B13 30mA	1/81
16 A	30 mA	B	100742	Ex9CBL-N 1P+N B16 30mA	1/81
20 A	30 mA	B	100743	Ex9CBL-N 1P+N B20 30mA	1/81
25 A	30 mA	B	100744	Ex9CBL-N 1P+N B25 30mA	1/81
32 A	30 mA	B	100745	Ex9CBL-N 1P+N B32 30mA	1/81
40 A	30 mA	B	100746	Ex9CBL-N 1P+N B40 30mA	1/81
6 A	100 mA	B	103202	Ex9CBL-N 1P+N B6 100mA	1/81
10 A	100 mA	B	103203	Ex9CBL-N 1P+N B10 100mA	1/81
13 A	100 mA	B	103204	Ex9CBL-N 1P+N B13 100mA	1/81
16 A	100 mA	B	103205	Ex9CBL-N 1P+N B16 100mA	1/81
20 A	100 mA	B	103206	Ex9CBL-N 1P+N B20 100mA	1/81
25 A	100 mA	B	103207	Ex9CBL-N 1P+N B25 100mA	1/81
32 A	100 mA	B	103208	Ex9CBL-N 1P+N B32 100mA	1/81
40 A	100 mA	B	103209	Ex9CBL-N 1P+N B40 100mA	1/81
6 A	300 mA	B	103210	Ex9CBL-N 1P+N B6 300mA	1/81
10 A	300 mA	B	103211	Ex9CBL-N 1P+N B10 300mA	1/81
13 A	300 mA	B	103212	Ex9CBL-N 1P+N B13 300mA	1/81
16 A	300 mA	B	103213	Ex9CBL-N 1P+N B16 300mA	1/81
20 A	300 mA	B	103214	Ex9CBL-N 1P+N B20 300mA	1/81
25 A	300 mA	B	103215	Ex9CBL-N 1P+N B25 300mA	1/81
32 A	300 mA	B	103216	Ex9CBL-N 1P+N B32 300mA	1/81
40 A	300 mA	B	103217	Ex9CBL-N 1P+N B40 300mA	1/81

Wiring diagram

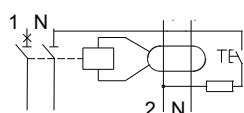

RCBOs Ex9CBL-N, 6 kA

AC type, characteristic C

- AC type of residual current circuit breaker sensitive on residual AC current
- C characteristic of installed circuit breaker
- Without time delay
- Surge current-proof 250 A
- Suitable for protection of people in case of direct and indirect contact with live parts and exposed conductive part during a fault, respectively
- Selective with upstream installed S or S+A type RCCB



Rated current	Rated residual current	MCB tripping char.	Article No.	Type	Packing
6 A	30 mA	C	100747	Ex9CBL-N 1P+N C6 30mA	1/81
10 A	30 mA	C	100748	Ex9CBL-N 1P+N C10 30mA	1/81
13 A	30 mA	C	100749	Ex9CBL-N 1P+N C13 30mA	1/81
16 A	30 mA	C	100750	Ex9CBL-N 1P+N C16 30mA	1/81
20 A	30 mA	C	100751	Ex9CBL-N 1P+N C20 30mA	1/81
25 A	30 mA	C	100752	Ex9CBL-N 1P+N C25 30mA	1/81
32 A	30 mA	C	100753	Ex9CBL-N 1P+N C32 30mA	1/81
40 A	30 mA	C	100754	Ex9CBL-N 1P+N C40 30mA	1/81
6 A	100 mA	C	103218	Ex9CBL-N 1P+N C6 100mA	1/81
10 A	100 mA	C	103219	Ex9CBL-N 1P+N C10 100mA	1/81
13 A	100 mA	C	103220	Ex9CBL-N 1P+N C13 100mA	1/81
16 A	100 mA	C	103221	Ex9CBL-N 1P+N C16 100mA	1/81
20 A	100 mA	C	103222	Ex9CBL-N 1P+N C20 100mA	1/81
25 A	100 mA	C	103223	Ex9CBL-N 1P+N C25 100mA	1/81
32 A	100 mA	C	103224	Ex9CBL-N 1P+N C32 100mA	1/81
40 A	100 mA	C	103225	Ex9CBL-N 1P+N C40 100mA	1/81
6 A	300 mA	C	103226	Ex9CBL-N 1P+N C6 300mA	1/81
10 A	300 mA	C	103227	Ex9CBL-N 1P+N C10 300mA	1/81
13 A	300 mA	C	103228	Ex9CBL-N 1P+N C13 300mA	1/81
16 A	300 mA	C	103229	Ex9CBL-N 1P+N C16 300mA	1/81
20 A	300 mA	C	103230	Ex9CBL-N 1P+N C20 300mA	1/81
25 A	300 mA	C	103231	Ex9CBL-N 1P+N C25 300mA	1/81
32 A	300 mA	C	103232	Ex9CBL-N 1P+N C32 300mA	1/81
40 A	300 mA	C	103233	Ex9CBL-N 1P+N C40 300mA	1/81

Wiring diagram

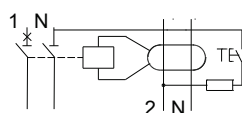

RCBOs Ex9CBL-N, 6 kA

A type, characteristic B

- A type of residual current circuit breaker sensitive on residual AC and pulsating DC current
- B characteristic of installed circuit breaker
- Without time delay
- Surge current-proof 250 A
- Suitable for protection of people in case of direct and indirect contact with live parts and exposed conductive part during a fault, respectively
- Selective with upstream installed S or S+A type RCCB



Rated current	Rated residual current	MCB tripping char.	Article No.	Type	Packing
6 A	30 mA	B	100755	Ex9CBL-N 1P+N B6 A 30mA	1/81
10 A	30 mA	B	100756	Ex9CBL-N 1P+N B10 A 30mA	1/81
13 A	30 mA	B	100757	Ex9CBL-N 1P+N B13 A 30mA	1/81
16 A	30 mA	B	100758	Ex9CBL-N 1P+N B16 A 30mA	1/81
20 A	30 mA	B	100759	Ex9CBL-N 1P+N B20 A 30mA	1/81
25 A	30 mA	B	100760	Ex9CBL-N 1P+N B25 A 30mA	1/81
32 A	30 mA	B	100761	Ex9CBL-N 1P+N B32 A 30mA	1/81
40 A	30 mA	B	100762	Ex9CBL-N 1P+N B40 A 30mA	1/81
6 A	100 mA	B	103234	Ex9CBL-N 1P+N B6 A 100mA	1/81
10 A	100 mA	B	103235	Ex9CBL-N 1P+N B10 A 100mA	1/81
13 A	100 mA	B	103236	Ex9CBL-N 1P+N B13 A 100mA	1/81
16 A	100 mA	B	103237	Ex9CBL-N 1P+N B16 A 100mA	1/81
20 A	100 mA	B	103238	Ex9CBL-N 1P+N B20 A 100mA	1/81
25 A	100 mA	B	103239	Ex9CBL-N 1P+N B25 A 100mA	1/81
32 A	100 mA	B	103240	Ex9CBL-N 1P+N B32 A 100mA	1/81
40 A	100 mA	B	103241	Ex9CBL-N 1P+N B40 A 100mA	1/81
6 A	300 mA	B	103242	Ex9CBL-N 1P+N B6 A 300mA	1/81
10 A	300 mA	B	103243	Ex9CBL-N 1P+N B10 A 300mA	1/81
13 A	300 mA	B	103244	Ex9CBL-N 1P+N B13 A 300mA	1/81
16 A	300 mA	B	103245	Ex9CBL-N 1P+N B16 A 300mA	1/81
20 A	300 mA	B	103246	Ex9CBL-N 1P+N B20 A 300mA	1/81
25 A	300 mA	B	103247	Ex9CBL-N 1P+N B25 A 300mA	1/81
32 A	300 mA	B	103248	Ex9CBL-N 1P+N B32 A 300mA	1/81
40 A	300 mA	B	103249	Ex9CBL-N 1P+N B40 A 300mA	1/81

Wiring diagram

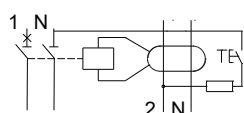

RCBOs Ex9CBL-N, 6 kA

A type, characteristic C

- A type of residual current circuit breaker sensitive on residual AC and pulsating DC current
- C characteristic of installed circuit breaker
- Without time delay
- Surge current-proof 250 A
- Suitable for protection of people in case of direct and indirect contact with live parts and exposed conductive part during a fault, respectively
- Selective with upstream installed S or S+A type RCCB



Rated current	Rated residual current	MCB tripping char.	Article No.	Type	Packing
6 A	30 mA	C	100763	Ex9CBL-N 1P+N C6 A 30mA	1/81
10 A	30 mA	C	100764	Ex9CBL-N 1P+N C10 A 30mA	1/81
13 A	30 mA	C	100765	Ex9CBL-N 1P+N C13 A 30mA	1/81
16 A	30 mA	C	100766	Ex9CBL-N 1P+N C16 A 30mA	1/81
20 A	30 mA	C	100767	Ex9CBL-N 1P+N C20 A 30mA	1/81
25 A	30 mA	C	100768	Ex9CBL-N 1P+N C25 A 30mA	1/81
32 A	30 mA	C	100769	Ex9CBL-N 1P+N C32 A 30mA	1/81
40 A	30 mA	C	100770	Ex9CBL-N 1P+N C40 A 30mA	1/81
6 A	100 mA	C	103250	Ex9CBL-N 1P+N C6 A 100mA	1/81
10 A	100 mA	C	103251	Ex9CBL-N 1P+N C10 A 100mA	1/81
13 A	100 mA	C	103252	Ex9CBL-N 1P+N C13 A 100mA	1/81
16 A	100 mA	C	103253	Ex9CBL-N 1P+N C16 A 100mA	1/81
20 A	100 mA	C	103254	Ex9CBL-N 1P+N C20 A 100mA	1/81
25 A	100 mA	C	103255	Ex9CBL-N 1P+N C25 A 100mA	1/81
32 A	100 mA	C	103256	Ex9CBL-N 1P+N C32 A 100mA	1/81
40 A	100 mA	C	103257	Ex9CBL-N 1P+N C40 A 100mA	1/81
6 A	300 mA	C	103258	Ex9CBL-N 1P+N C6 A 300mA	1/81
10 A	300 mA	C	103259	Ex9CBL-N 1P+N C10 A 300mA	1/81
13 A	300 mA	C	103260	Ex9CBL-N 1P+N C13 A 300mA	1/81
16 A	300 mA	C	103261	Ex9CBL-N 1P+N C16 A 300mA	1/81
20 A	300 mA	C	103262	Ex9CBL-N 1P+N C20 A 300mA	1/81
25 A	300 mA	C	103263	Ex9CBL-N 1P+N C25 A 300mA	1/81
32 A	300 mA	C	103264	Ex9CBL-N 1P+N C32 A 300mA	1/81
40 A	300 mA	C	103265	Ex9CBL-N 1P+N C40 A 300mA	1/81

Wiring diagram

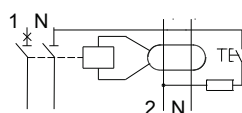

Information sticker

- Sticker with information about regular monthly testing
- Languages EN, CZ, SK, FR, RU, PL, DE, RO
- In a scope of delivery of all magnetic RCCBs and RCBOs NOARK, spare part

Description	Languages	Article No.	Type	Packing
Information sticker	EN, CZ, SK, FR, RU, PL, DE, RO	101445	YS31	1

RCD add-on blocks Ex9LE



- Residual Current add-on blocks according to IEC / EN 61009
- For combination with MCBs Ex9B
- Conditional rated short circuit strength I_{nc} 10 kA in combination with Ex9BH and 6 kA with Ex9BN
- 1+N up to 4-pole versions
- Rated residual current 10, 30, 100, 300 mA
- Rated currents up to 40 and 63 A
- Rated operational voltage 230/400 V AC
- AC type of RCD

Ex9LE residual current add-on blocks are suitable for domestic as well as industrial applications. They are based on electronic technology. It brings advantages of more accurate measuring of residual current and, as a consequence, reduction of unwanted tripping. (For possible use of this device, local legal requirements and conditions must be fulfilled.) These devices also do not suffer with magnetization of the tripping unit. Thus, regular testing is not necessary to preserve function of the device. To fulfill prescribed mandatory testing given by the product standard, it is recommended to test the device regularly with a period of one year.

Given pole version of the RCD add-on block must be combined with MCB of line Ex9B in the following way. 1+N-pole version of RCD add-on block is possible to combine with 1-pole MCB; 2-pole RCD block with 1+N or 2-pole MCB; 3-pole and 3+N-pole RCD block with 3-pole MCB, 4-pole RCD block with 3+N or 4-pole MCB. These variants enable to create very various combinations to obtain special devices with RCBO functionality.

Type Key

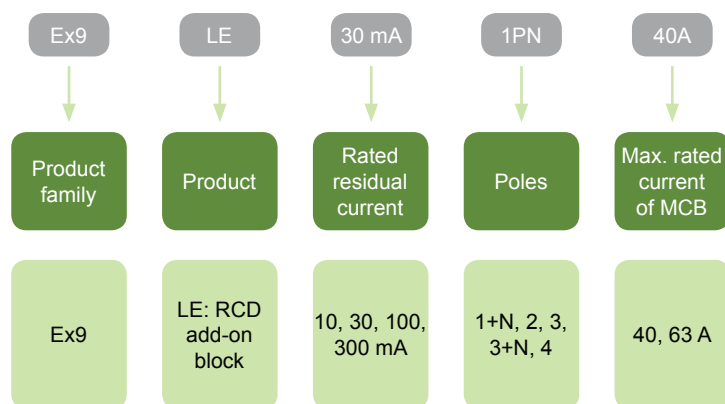

Certification marks



RCD add-on blocks Ex9LE

Mounting onto MCB



Aux. or signal contacts
AX, AL, AXL
Up to 3 units

Voltage or trip releases
SHT, UVT, OVT
Up to 2 units

MCB
Ex9B
1, 1+N, 2, 3, 3+N, 4-pole

RCD add-on block
Ex9LE
1+N, 2, 3, 3+N, 4-pole

RCD add-on blocks are mounted to the MCBs Ex9B from the right.

Use of other MCB accessories is not affected by installation of RCD add-on block anyhow.

Input voltage must be connected via MCB, other connection is not acceptable.

RCD add-on blocks Ex9LE

1+N-pole version

- AC type of residual current device sensitive on residual AC current
- Without time delay
- Surge current-proof 250 A
- 10 and 30 mA versions suitable for protection of people in case of direct and indirect contact with live parts and exposed conductive part during a fault, respectively
- 100 and 300 mA versions suitable for protection against fire or as a protection against leakage currents (e.g. due to imperfect isolation)
- For combination with 1-pole version of MCB Ex9B



Rated residual current	Rated current	Poles	Article No.	Type	Packing
10 mA	40 A	1+N	100557	Ex9LE 10mA 1PN 40A	1/54
10 mA	63 A	1+N	100562	Ex9LE 10mA 1PN 63A	1/54
30 mA	40 A	1+N	100567	Ex9LE 30mA 1PN 40A	1/54
30 mA	63 A	1+N	100572	Ex9LE 30mA 1PN 63A	1/54
100 mA	40 A	1+N	100577	Ex9LE 100mA 1PN 40A	1/54
100 mA	63 A	1+N	100582	Ex9LE 100mA 1PN 63A	1/54
300 mA	40 A	1+N	100587	Ex9LE 300mA 1PN 40A	1/54
300 mA	63 A	1+N	100592	Ex9LE 300mA 1PN 63A	1/54

Wiring diagram

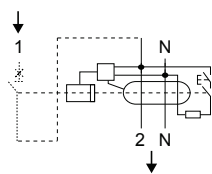

2-pole version

- AC type of residual current device sensitive on residual AC current
- Without time delay
- Surge current-proof 250 A
- 10 and 30 mA versions suitable for protection of people in case of direct and indirect contact with live parts and exposed conductive part during a fault, respectively
- 100 and 300 mA versions suitable for protection against fire or as a protection against leakage currents (e.g. due to imperfect isolation)
- For combination with 1+N-pole or 2-pole version of MCB Ex9B



Rated residual current	Rated current	Poles	Article No.	Type	Packing
10 mA	40 A	2	100558	Ex9LE 10mA 2P 40A	1/45
10 mA	63 A	2	100563	Ex9LE 10mA 2P 63A	1/45
30 mA	40 A	2	100568	Ex9LE 30mA 2P 40A	1/45
30 mA	63 A	2	100573	Ex9LE 30mA 2P 63A	1/45
100 mA	40 A	2	100578	Ex9LE 100mA 2P 40A	1/45
100 mA	63 A	2	100583	Ex9LE 100mA 2P 63A	1/45
300 mA	40 A	2	100588	Ex9LE 300mA 2P 40A	1/45
300 mA	63 A	2	100593	Ex9LE 300mA 2P 63A	1/45

Wiring diagram

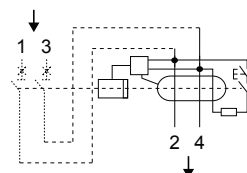

RCD add-on blocks Ex9LE

3-pole version

- AC type of residual current device sensitive on residual AC current
- Without time delay
- Surge current-proof 250 A
- 10 and 30 mA versions suitable for protection of people in case of direct and indirect contact with live parts and exposed conductive part during a fault, respectively
- 100 and 300 mA versions suitable for protection against fire or as a protection against leakage currents (e.g. due to imperfect isolation)
- For combination with 3-pole version of MCB Ex9B



Rated residual current	Rated current	Poles	Article No.	Type	Packing
10 mA	40 A	3	100559	Ex9LE 10mA 3P 40A	1/27
10 mA	63 A	3	100564	Ex9LE 10mA 3P 63A	1/27
30 mA	40 A	3	100569	Ex9LE 30mA 3P 40A	1/27
30 mA	63 A	3	100574	Ex9LE 30mA 3P 63A	1/27
100 mA	40 A	3	100579	Ex9LE 100mA 3P 40A	1/27
100 mA	63 A	3	100584	Ex9LE 100mA 3P 63A	1/27
300 mA	40 A	3	100589	Ex9LE 300mA 3P 40A	1/27
300 mA	63 A	3	100594	Ex9LE 300mA 3P 63A	1/27

Wiring diagram

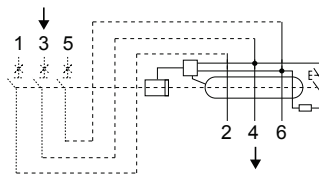

3+N-pole version

- AC type of residual current device sensitive on residual AC current
- Without time delay
- Surge current-proof 250 A
- 10 and 30 mA versions suitable for protection of people in case of direct and indirect contact with live parts and exposed conductive part during a fault, respectively
- 100 and 300 mA versions suitable for protection against fire or as a protection against leakage currents (e.g. due to imperfect isolation)
- For combination with 3-pole version of MCB Ex9B



Rated residual current	Rated current	Poles	Article No.	Type	Packing
10 mA	40 A	3+N	100560	Ex9LE 10mA 3PN 40A	1/27
10 mA	63 A	3+N	100565	Ex9LE 10mA 3PN 63A	1/27
30 mA	40 A	3+N	100570	Ex9LE 30mA 3PN 40A	1/27
30 mA	63 A	3+N	100575	Ex9LE 30mA 3PN 63A	1/27
100 mA	40 A	3+N	100580	Ex9LE 100mA 3PN 40A	1/27
100 mA	63 A	3+N	100585	Ex9LE 100mA 3PN 63A	1/27
300 mA	40 A	3+N	100590	Ex9LE 300mA 3PN 40A	1/27
300 mA	63 A	3+N	100595	Ex9LE 300mA 3PN 63A	1/27

Wiring diagram

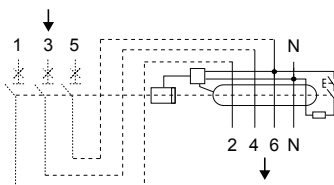

RCD add-on blocks Ex9LE

4-pole version

- AC type of residual current device sensitive on residual AC current
- Without time delay
- Surge current-proof 250 A
- 10 and 30 mA versions suitable for protection of people in case of direct and indirect contact with live parts and exposed conductive part during a fault, respectively
- 100 and 300 mA versions suitable for protection against fire or as a protection against leakage currents (e.g. due to imperfect isolation)
- For combination with 3+N-pole or 4-pole version of MCB Ex9B



Rated residual current	Rated current	Poles	Article No.	Type	Packing
10 mA	40 A	4	100561	Ex9LE 10mA 4P 40A	1/24
10 mA	63 A	4	100566	Ex9LE 10mA 4P 63A	1/24
30 mA	40 A	4	100571	Ex9LE 30mA 4P 40A	1/24
30 mA	63 A	4	100576	Ex9LE 30mA 4P 63A	1/24
100 mA	40 A	4	100581	Ex9LE 100mA 4P 40A	1/24
100 mA	63 A	4	100586	Ex9LE 100mA 4P 63A	1/24
300 mA	40 A	4	100591	Ex9LE 300mA 4P 40A	1/24
300 mA	63 A	4	100596	Ex9LE 300mA 4P 63A	1/24

Wiring diagram

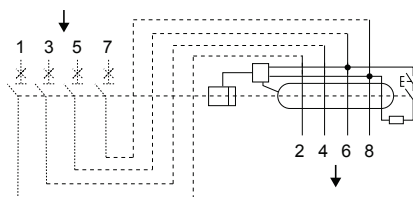



Accessories for Ex9B and Ex9PN



- Accessories for installation devices Ex9B and Ex9PN
- Auxiliary contacts synchronous with main contacts of the device
- Signal contacts active on electrical tripping of the circuit breaker (tripping signal contacts)
- Shunt trip releases
- Undervoltage releases
- Overvoltage release
- According to EN 60947-1 and EN 60947-5-1

Accessories is designed in the way to be possible to combine different types with one installation device. It can be used up to two releases plus up to three units of auxiliary or signal contacts (two units in case of AX3122 with two pairs of contacts) plus one unit of RCD-block (only for Ex9B MCBs).

Release units are mounted from the left to the installation device.

Auxiliary and signal contact units to be mounted from the left to the device or to the release unit(s) when installed. Contact units are equipped with changeover (CO) combination(s) of contacts.

Type Key

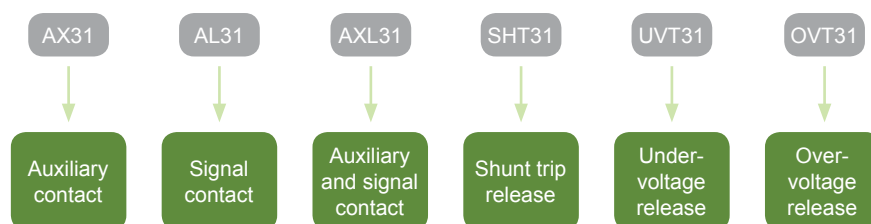

Accessories for Ex9B and Ex9PN

Auxiliary and signal contact units



Function	Contacts	Article No.	Type	Packing
Auxiliary	1 CO	100540	AX3111	1/96
Auxiliary	2 CO	100542	AX3122	1/96
Signal	1 CO	100541	AL3111	1/96
Auxiliary + signal	1 CO + 1 CO	100543	AXL31	1/96

Wiring diagrams

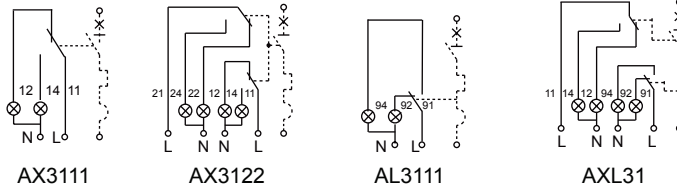

Technical data p. 141

Shunt trip releases



Aux. cont.	AC Op. Volt.	DC Op. Volt.	Article No.	Type	Packing
-	110 — 415	110 — 130	100544	SHT31 110V-415V AC/110V-130V DC	1/96
-	48	48	100545	SHT31 48V AC/DC	1/96
-	12 — 24	12 — 24	100546	SHT31 12-24V AC/DC	1/96
1 CO	110 — 415	110 — 130	100547	SHT3111 110V-415V AC/110V-130V DC	1/96
1 CO	48	48	100548	SHT3111 48V AC/DC	1/96
1 CO	12 — 24	12 — 24	100549	SHT3111 12-24V AC/DC	1/96

Wiring diagrams

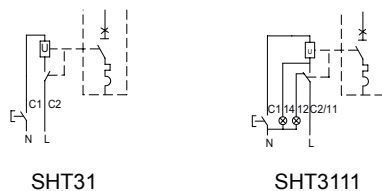

Technical data p. 143

Accessories for Ex9B and Ex9PN

Undervoltage releases



Aux. cont.	AC Op. Volt.	DC Op. Volt.	Article No.	Type	Packing
-	220 — 240	-	100550	UVT31 220-240V AC	1/96
-	48	48	100551	UVT31 48V AC/DC	1/96
1 NC	220 — 240	-	100552	UVT3101 220-240V AC	1/96
1 NC	48	48	100553	UVT3101 48V AC/DC	1/96
1 NO	220 — 240	-	100554	UVT3110 220-240V AC	1/96
1 NO	48	48	100555	UVT3110 48V AC/DC	1/96

Wiring diagrams

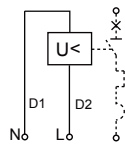

UVT31

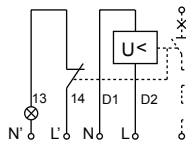

UVT3101

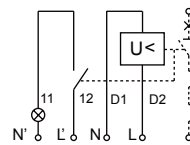

UVT3110

Technical data p. 145

Overvoltage releases

- Overvoltage release is not a protection against transient overvoltage and does not supersede surge protection devices



Aux. cont.	AC Op. Volt.	DC Op. Volt.	Article No.	Type	Packing
-	280V AC±5%	-	100556	OVT31 280V AC±5%	1/96

Wiring diagram

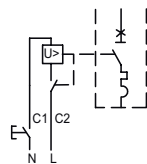

OVT31

Technical data p. 147



Accessories for RCBOs



- Accessories for RCBOs line Ex9CBL
- Tested according to IEC / EN 60947-5
- Mounted from left side
- Shunt trip releases
- Undervoltage releases

Accessories is designed in the way to be possible to combine different types of releases with one RCBO. It can be used up to two releases with one RCBO.

Shunt trip release SHTC31 can be used for remote switch off function, undervoltage release UVTC31 to switch connected device off in case of voltage drop.

Release units are mounted from the left side to the RCBO.

Type Key

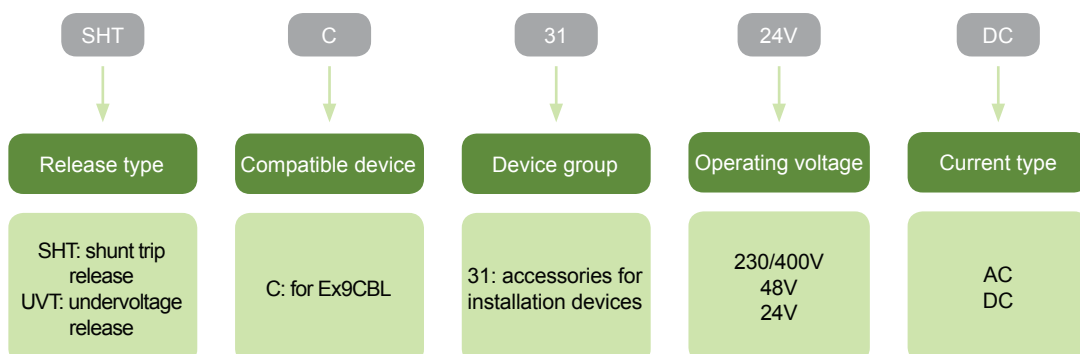

Accessories for RCBOs

Shunt trip releases

- With integrated auxiliary contact



Operating voltage	Auxiliary contacts	Article No.	Type	Packing
230/400 V AC	1 CO	103548	SHTC31 230/400V AC	1/96
24 V AC	1 CO	103551	SHTC31 24V AC	1/96
48 V DC	1 CO	103550	SHTC31 48V DC	1/96
24 V DC	1 CO	103549	SHTC31 24V DC	1/96

Wiring diagram

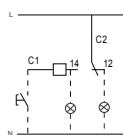

SHTC31

Technical data p. 149

Undervoltage releases



Operating voltage	Article No.	Type	Packing
230 V AC	103552	UVTC31 230V AC	1/96

Wiring diagram



UVTC31

Technical data p. 151

Surge Protection Devices Ex9UE



- Surge Protection Devices
- Type 1+2 (Class I+II, T1+T2, B+C)
Type 2 (Class II, T2, C)
- Tested according to EN 61643-11
- Maximum continuous operational voltage U_c 275 V up to 440 V AC
- Versions with 1+0, 1+1, 2+0, 3+0, 3+1 and 4+0 connection
- Plug-in module design
- With and without remote indication contact
- Device status indicator

Surge protection devices Ex9UE are used as a protection of electrical installations against transient overvoltage and indirect lightning strokes. These SPDs are designed and certified according to EN 61643-11.

Indication unit helps users to know the status of device and remote-signal port is able to provide remote indication and alarm.

Plug-in module design makes it convenient to change used module without device disconnection.

Type Key

Ex9	UE	1+2	12.5	R	1P	275	
Product family	Product	Class	Current	Signaling contact	Type of connection	Max. oper. voltage	Plug-in module
Ex9	UE: AC Surge Protective Devices	1+2: T1+T2 (cl. I+II, B+C) 2: T2 (cl. II, C)	I_{imp} (10/350 μ s) 12.5 kA 50 kA I_n (8/20 μ s) 20 kA 40 kA	R: Yes _: No	1P: 1+0 1PN: 1+1 2P: 2+0 3P 3+0 3PN: 3+1 4P: 4+0 NPE: 0+1	275 V AC _: NPE 275 V AC 320 V AC 385 V AC 440 V AC _: NPE	_: Complete device M: Plug-in module only

Certification marks



Surge Protection Devices Ex9UE1+2

Type 1+2 SPDs (Class I+II, T1+T2, B+C) complete devices, $I_{imp} = 12.5 \text{ kA (10/350 } \mu\text{s)}$

- Maximum impulse current I_{imp} 12.5 kA (10/350 μs) per phase / 50 kA (10/350 μs) for NPE (+1) module
- Nominal discharge current I_n 25 kA (8/20 μs) per phase / 50 kA (8/20 μs) for NPE (+1) module
- Maximum discharge current I_{max} 50 kA (8/20 μs)
- Maximum continuous operational voltage U_c 275 V AC per phase / 255 V AC for NPE (+1) module
- Due to I_{imp} 12.5 kA per pole suitable for LPL III and LPL IV according to EN 62305 in standard 3-phase TN-C and TN-S installations



Operating voltage	Connection	Signaling contact	Article No.	Type	Packing
275 V AC	1+0	no	103332	Ex9UE1+2 12.5 1P 275	1/96
275 V AC	1+0	yes	103333	Ex9UE1+2 12.5R 1P 275	1/96
275 V AC	1+1	no	103334	Ex9UE1+2 12.5 1PN 275	1/60
275 V AC	1+1	yes	103335	Ex9UE1+2 12.5R 1PN 275	1/60
275 V AC	2+0	no	103336	Ex9UE1+2 12.5 2P 275	1/60
275 V AC	2+0	yes	103337	Ex9UE1+2 12.5R 2P 275	1/60
275 V AC	3+0	no	103338	Ex9UE1+2 12.5 3P 275	1/54
275 V AC	3+0	yes	103339	Ex9UE1+2 12.5R 3P 275	1/54
275 V AC	3+1	no	103340	Ex9UE1+2 12.5 3PN 275	1/45
275 V AC	3+1	yes	103341	Ex9UE1+2 12.5R 3PN 275	1/45
275 V AC	4+0	no	103342	Ex9UE1+2 12.5 4P 275	1/45
275 V AC	4+0	yes	103343	Ex9UE1+2 12.5R 4P 275	1/45

Type 1+2 spare modules



Max. oper. voltage U_c	Max. imp. current I_{imp}	Article No.	Type
275 V AC	12.5 kA	103330	Ex9UE1+2 12.5 1P 275 M
N-PE	50 kA	103331	Ex9UE1+2 NPE M

Surge Protection Devices Ex9UE2

Type 2 SPD (Class II, T2, C) complete devices, $I_n = 20 \text{ kA (8/20 } \mu\text{s)}$

- Nominal discharge current I_n 20 kA (8/20 μs) per phase / 40 kA (8/20 μs) for NPE (+1) module
- Maximum discharge current I_{max} 40 kA (8/20 μs)
- Maximum continuous operational voltage U_c 275 V AC up to 440 V AC per phase / 255 V AC for NPE (+1) module



Max. oper. voltage U_c	Connection	Signaling contact	Article No.	Type	Packing
275 V AC	1+0	no	103347	Ex9UE2 20 1P 275	1/96
275 V AC	1+0	yes	103348	Ex9UE2 20R 1P 275	1/96
275 V AC	1+1	no	103349	Ex9UE2 20 1PN 275	1/60
275 V AC	1+1	yes	103350	Ex9UE2 20R 1PN 275	1/60
275 V AC	2+0	no	103351	Ex9UE2 20 2P 275	1/60
275 V AC	2+0	yes	103352	Ex9UE2 20R 2P 275	1/60
275 V AC	3+0	no	103353	Ex9UE2 20 3P 275	1/54
275 V AC	3+0	yes	103354	Ex9UE2 20R 3P 275	1/54
275 V AC	3+1	no	103355	Ex9UE2 20 3PN 275	1/45
275 V AC	3+1	yes	103356	Ex9UE2 20R 3PN 275	1/45
275 V AC	4+0	no	103357	Ex9UE2 20 4P 275	1/45
275 V AC	4+0	yes	103358	Ex9UE2 20R 4P 275	1/45
320 V AC	1+0	no	103754	Ex9UE2 20 1P 320	1/96
320 V AC	1+0	yes	103755	Ex9UE2 20R 1P 320	1/96
320 V AC	1+1	no	103756	Ex9UE2 20 1PN 320	1/60
320 V AC	1+1	yes	103757	Ex9UE2 20R 1PN 320	1/60
320 V AC	2+0	no	103758	Ex9UE2 20 2P 320	1/60
320 V AC	2+0	yes	103759	Ex9UE2 20R 2P 320	1/60
320 V AC	3+0	no	103760	Ex9UE2 20 3P 320	1/54
320 V AC	3+0	yes	103761	Ex9UE2 20R 3P 320	1/54
320 V AC	3+1	no	103762	Ex9UE2 20 3PN 320	1/45
320 V AC	3+1	yes	103763	Ex9UE2 20R 3PN 320	1/45
320 V AC	4+0	no	103764	Ex9UE2 20 4P 320	1/45
320 V AC	4+0	yes	103765	Ex9UE2 20R 4P 320	1/45
385 V AC	1+0	no	103766	Ex9UE2 20 1P 385	1/96
385 V AC	1+0	yes	103767	Ex9UE2 20R 1P 385	1/96
385 V AC	1+1	no	103768	Ex9UE2 20 1PN 385	1/60
385 V AC	1+1	yes	103769	Ex9UE2 20R 1PN 385	1/60
385 V AC	2+0	no	103770	Ex9UE2 20 2P 385	1/60
385 V AC	2+0	yes	103771	Ex9UE2 20R 2P 385	1/60
385 V AC	3+0	no	103772	Ex9UE2 20 3P 385	1/54
385 V AC	3+0	yes	103773	Ex9UE2 20R 3P 385	1/54
385 V AC	3+1	no	103774	Ex9UE2 20 3PN 385	1/45
385 V AC	3+1	yes	103775	Ex9UE2 20R 3PN 385	1/45
385 V AC	4+0	no	103776	Ex9UE2 20 4P 385	1/45
385 V AC	4+0	yes	103777	Ex9UE2 20R 4P 385	1/45
440 V AC	1+0	no	103359	Ex9UE2 20 1P 440	1/96
440 V AC	1+0	yes	103360	Ex9UE2 20R 1P 440	1/96
440 V AC	1+1	no	103361	Ex9UE2 20 1PN 440	1/60
440 V AC	1+1	yes	103362	Ex9UE2 20R 1PN 440	1/60
440 V AC	2+0	no	103363	Ex9UE2 20 2P 440	1/60
440 V AC	2+0	yes	103364	Ex9UE2 20R 2P 440	1/60
440 V AC	3+0	no	103365	Ex9UE2 20 3P 440	1/54
440 V AC	3+0	yes	103366	Ex9UE2 20R 3P 440	1/54
440 V AC	3+1	no	103367	Ex9UE2 20 3PN 440	1/45
440 V AC	3+1	yes	103368	Ex9UE2 20R 3PN 440	1/45
440 V AC	4+0	no	103369	Ex9UE2 20 4P 440	1/45
440 V AC	4+0	yes	103370	Ex9UE2 20R 4P 440	1/45

Type 2 SPD spare modules



Max. oper. voltage U_c	Nominal current I_n	Article No.	Type
275 V AC	20 kA	103344	Ex9UE2 20 1P 275 M
320 V AC	20 kA	103752	Ex9UE2 20 1P 320 M
385 V AC	20 kA	103753	Ex9UE2 20 1P 385 M
440 V AC	20 kA	103345	Ex9UE2 20 1P 440 M
N-PE	40 kA	103346	Ex9UE2 40 NPE M



Installation relays Ex9CH20



- Installation relays Ex9CH20
- Meet requirements of IEC / EN 61095
- Rated current up to 20 A
- Control coil voltage 24, 230 or 240 V AC
- Rated frequency 50/60 Hz
- 2 or 4-contact versions
- Various contact combinations

Modular relays Ex9CH20 are suitable for household and building modular distribution boards. They are mainly used in building automation processes for switching and controlling lightings, heating systems, ventilations, pumps, heating pumps and other applications.

Optical indicator on the front side indicates status of the contacts and voltage on control coil.

Type Key

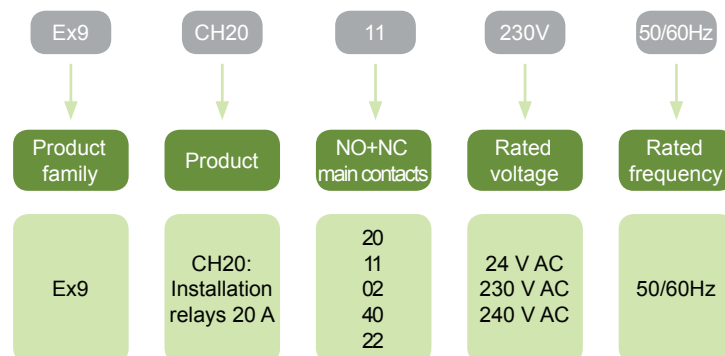

Certification marks



Installation relays Ex9CH20

Installation relays 20 A, width 1MU



Control voltage	Contacts NO+NC	Article No.	Type	Packing
230 V AC	20	102399	Ex9CH20 20 230V 50/60Hz	2/162
230 V AC	11	102402	Ex9CH20 11 230V 50/60Hz	2/162
230 V AC	02	102405	Ex9CH20 02 230V 50/60Hz	2/162
240 V AC	20	102400	Ex9CH20 20 240V 50/60Hz	2/162
240 V AC	11	102403	Ex9CH20 11 240V 50/60Hz	2/162
240 V AC	02	102406	Ex9CH20 02 240V 50/60Hz	2/162
24 V AC	20	102398	Ex9CH20 20 24V 50/60Hz	2/162
24 V AC	11	102401	Ex9CH20 11 24V 50/60Hz	2/162
24 V AC	02	102404	Ex9CH20 02 24V 50/60Hz	2/162

Installation relays 20 A, width 2MU



Control voltage	Contacts NO+NC	Article No.	Type	Packing
230 V AC	40	102408	Ex9CH20 40 230V 50/60Hz	1/81
230 V AC	22	102410	Ex9CH20 22 230V 50/60Hz	1/81
24 V AC	40	102407	Ex9CH20 40 24V 50/60Hz	1/81
24 V AC	22	102409	Ex9CH20 22 24V 50/60Hz	1/81

Installation contactors Ex9CH



- Installation contactors Ex9CH
- Meet requirements of IEC / EN 61095
- Rated current up to 25, 40, 63 A
- Control coil voltage 24, 230 or 240 V AC
- Rated frequency 50/60 Hz
- 2 or 4-contact versions
- Various contact combinations

Modular contactors Ex9CH are suitable for household and building modular distribution boards. They are mainly used in building automation processes for switching and controlling lightings, heating systems, ventilations, pumps, heating pumps and other applications.

Optical indicator on the front side indicates status of the contacts and voltage on control coil.

Type Key

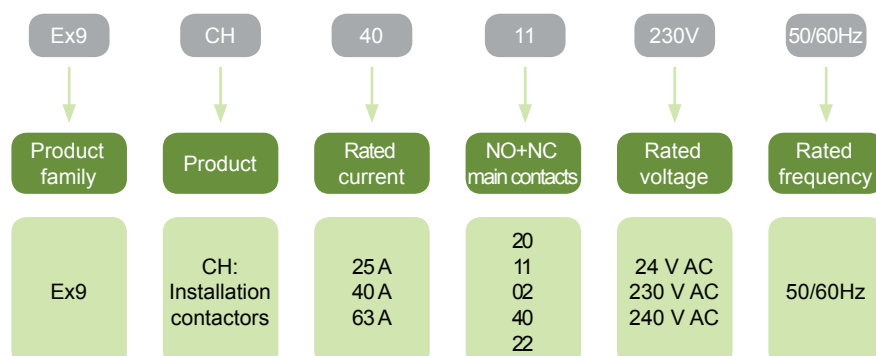

Certification marks



Installation contactors Ex9CH

Installation contactors 25 A, width 2MU



Control voltage	Contacts NO+NC	Article No.	Type	Packing
230 V AC	40	102412	Ex9CH25 40 230V 50/60Hz	1/81
230 V AC	22	102414	Ex9CH25 22 230V 50/60Hz	1/81
24 V AC	40	102411	Ex9CH25 40 24V 50/60Hz	1/81
24 V AC	22	102413	Ex9CH25 22 24V 50/60Hz	1/81

Installation contactors 40 A, width 2MU



Control voltage	Contacts NO+NC	Article No.	Type	Packing
230 V AC	20	102416	Ex9CH40 20 230V 50/60Hz	1/81
230 V AC	11	102418	Ex9CH40 11 230V 50/60Hz	1/81
24 V AC	20	102415	Ex9CH40 20 24V 50/60Hz	1/81
24 V AC	11	102417	Ex9CH40 11 24V 50/60Hz	1/81

Installation contactors 40 A, width 3MU



Control voltage	Contacts NO+NC	Article No.	Type	Packing
230 V AC	40	102420	Ex9CH40 40 230V 50/60Hz	1/54
240 V AC	40	102421	Ex9CH40 40 240V 50/60Hz	1/54
24 V AC	40	102419	Ex9CH40 40 24V 50/60Hz	1/54

Installation contactors 63 A, width 2MU



Control voltage	Contacts NO+NC	Article No.	Type	Packing
230 V AC	20	102423	Ex9CH63 20 230V 50/60Hz	1/81
230 V AC	11	102425	Ex9CH63 11 230V 50/60Hz	1/81
24 V AC	20	102422	Ex9CH63 20 24V 50/60Hz	1/81
24 V AC	11	102424	Ex9CH63 11 24V 50/60Hz	1/81

Installation contactors 63 A, width 3MU



Control voltage	Contacts NO+NC	Article No.	Type	Packing
230 V AC	40	102427	Ex9CH63 40 230V 50/60Hz	1/54
240 V AC	40	102428	Ex9CH63 40 240V 50/60Hz	1/54
24 V AC	40	102426	Ex9CH63 40 24V 50/60Hz	1/54

Change-Over Switches Ex9BT



- Modular Change-Over Switches
- Meet requirements of EN 60669-1
- Rated current 16 and 32 A
- Rated operating voltage 230/400 V AC
- With and without independent LED signal lamp
- LED rated voltage 48 or 230 V AC/DC
- 1 up to 4-pole versions
- Various contact combinations

Installation switches and change-over switches Ex9BT for switching of auxiliary, control, measuring and other circuits.

Variants with NO, NC and CO contacts. Basic versions with only NO contacts are equipped with toggle in green colour. Types with only NC contacts are delivered with red toggles. All other variants are designed with neutral black toggle.

Besides versions with switch function only, there are available also variants where combined switch and signal lamp in one devices. The signal lamps have separate circuit independent on the contact ones. The colour of used LED is white.

Type Key

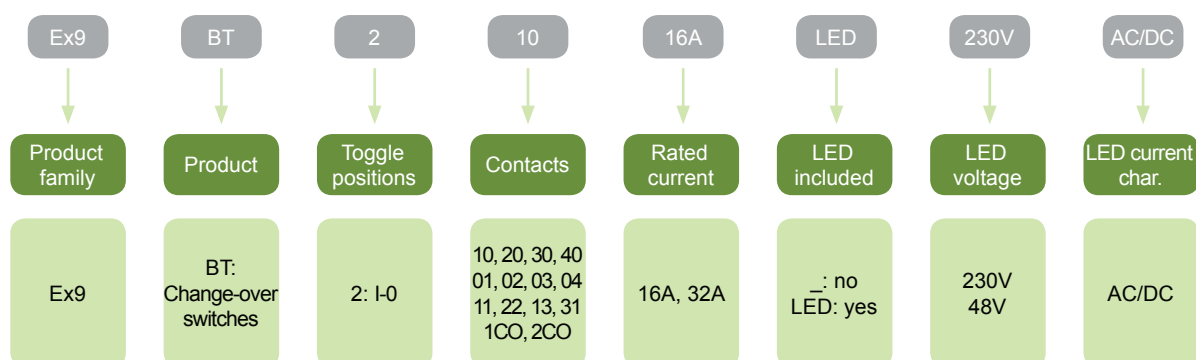

Certification marks



Change-Over Switches Ex9BT

Change-over switches without LED signal lamp



Rated current	Contacts	Toggle color	Article No.	Type	Packing
16 A	1 NO	green	102656	Ex9BT2 10 16A	1/12/144
16 A	2 NO	green	102657	Ex9BT2 20 16A	1/12/144
16 A	3 NO	green	102658	Ex9BT2 30 16A	1/12/144
16 A	4 NO	green	102659	Ex9BT2 40 16A	1/12/144
16 A	1 NC	red	102660	Ex9BT2 01 16A	1/12/144
16 A	2 NC	red	102661	Ex9BT2 02 16A	1/12/144
16 A	3 NC	red	102662	Ex9BT2 03 16A	1/12/144
16 A	4 NC	red	102663	Ex9BT2 04 16A	1/12/144
16 A	1 NO+1 NC	black	102664	Ex9BT2 11 16A	1/12/144
16 A	2 NO+2 NC	black	102665	Ex9BT2 22 16A	1/12/144
16 A	1 NO+3 NC	black	102666	Ex9BT2 13 16A	1/12/144
16 A	3 NO+1 NC	black	102667	Ex9BT2 31 16A	1/12/144
16 A	1 CO	black	102668	Ex9BT2 1CO 16A	1/12/144
16 A	2 CO	black	102669	Ex9BT2 2CO 16A	1/12/144
32 A	2 NO	green	102670	Ex9BT2 20 32A	1/12/144
32 A	4 NO	green	102671	Ex9BT2 40 32A	1/12/144
32 A	2 NC	red	102672	Ex9BT2 02 32A	1/12/144
32 A	4 NC	red	102673	Ex9BT2 04 32A	1/12/144

Change-over switches with LED signal lamp, rated current 16 A

- LED colour white



Contacts	LED voltage	Toggle color	Article No.	Type	Packing
2 NO	230 V AC/DC	green	102674	Ex9BT2 20 16A LED230VAC/DC	1/12/144
2 NO	48 V AC/DC	green	102675	Ex9BT2 20 16A LED48VAC/DC	1/12/144
2 NC	230 V AC/DC	red	102676	Ex9BT2 02 16A LED230VAC/DC	1/12/144
2 NC	48 V AC/DC	red	102677	Ex9BT2 02 16A LED48VAC/DC	1/12/144
1 CO	230 V AC/DC	black	102678	Ex9BT2 1CO 16A LED230VAC/DC	1/12/144
1 CO	48 V AC/DC	black	102679	Ex9BT2 1CO 16A LED48VAC/DC	1/12/144

Signal lamps Ex9PD



- Installation Signal Lamps
- Meet requirements of IEC / EN 60947-5-1
- LED technology
- Rated operating voltage 6.3 to 230 V AC/DC
- Width 1 MU
- 1 and 2-LED versions
- Various colours and colour combinations

Installation signal lamps Ex9PD are designed and tested according to standard IEC/EN 60947-5-1. They are based on LED technology and suitable e.g. for circuit status indication.

There are available versions with rated operating voltage from 6.3 up to 230 V AC/DC, with 1 and 2 LEDs in various colours and also all combinations of LED colours in double lamp devices to cover all possible applications.

Type Key

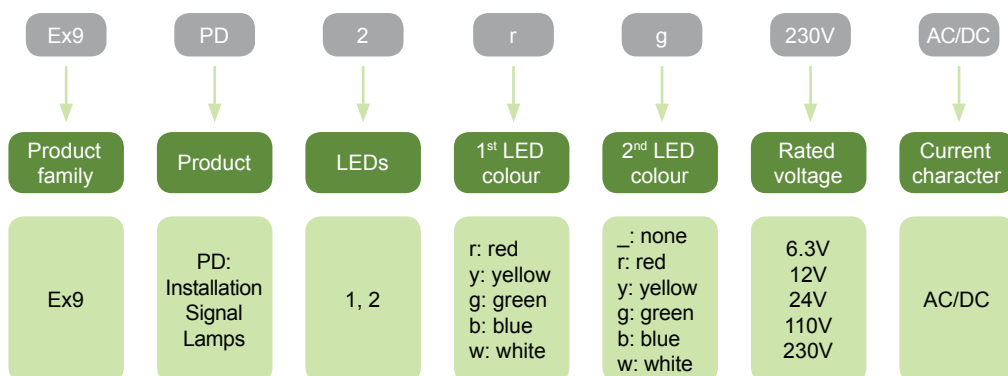

Certification marks



Signal lamps Ex9PD

1-LED version



No of LEDs	Colour	Article No.	Type	Packing
1	red	102429	Ex9PD1r 6.3V AC/DC	2/162
1	red	102430	Ex9PD1r 12V AC/DC	2/162
1	red	102431	Ex9PD1r 24V AC/DC	2/162
1	red	102432	Ex9PD1r 110V AC/DC	2/162
1	red	102433	Ex9PD1r 230V AC/DC	2/162
1	yellow	102434	Ex9PD1y 6.3V AC/DC	2/162
1	yellow	102435	Ex9PD1y 12V AC/DC	2/162
1	yellow	102436	Ex9PD1y 24V AC/DC	2/162
1	yellow	102437	Ex9PD1y 110V AC/DC	2/162
1	yellow	102438	Ex9PD1y 230V AC/DC	2/162
1	green	102439	Ex9PD1g 6.3V AC/DC	2/162
1	green	102440	Ex9PD1g 12V AC/DC	2/162
1	green	102441	Ex9PD1g 24V AC/DC	2/162
1	green	102442	Ex9PD1g 110V AC/DC	2/162
1	green	102443	Ex9PD1g 230V AC/DC	2/162
1	blue	102444	Ex9PD1b 6.3V AC/DC	2/162
1	blue	102445	Ex9PD1b 12V AC/DC	2/162
1	blue	102446	Ex9PD1b 24V AC/DC	2/162
1	blue	102447	Ex9PD1b 110V AC/DC	2/162
1	blue	102448	Ex9PD1b 230V AC/DC	2/162
1	white	102449	Ex9PD1w 6.3V AC/DC	2/162
1	white	102450	Ex9PD1w 12V AC/DC	2/162
1	white	102451	Ex9PD1w 24V AC/DC	2/162
1	white	102452	Ex9PD1w 110V AC/DC	2/162
1	white	102453	Ex9PD1w 230V AC/DC	2/162

2-LED version



No of LEDs	Colour	Article No.	Type	Packing
2	green, green	102454	Ex9PD2gg 6.3V AC/DC	2/162
2	green, green	102455	Ex9PD2gg 12V AC/DC	2/162
2	green, green	102456	Ex9PD2gg 24V AC/DC	2/162
2	green, green	102457	Ex9PD2gg 110V AC/DC	2/162
2	green, green	102458	Ex9PD2gg 230V AC/DC	2/162
2	green, red	102459	Ex9PD2gr 6.3V AC/DC	2/162
2	green, red	102460	Ex9PD2gr 12V AC/DC	2/162
2	green, red	102461	Ex9PD2gr 24V AC/DC	2/162
2	green, red	102462	Ex9PD2gr 110V AC/DC	2/162
2	green, red	102463	Ex9PD2gr 230V AC/DC	2/162
2	green, yellow	102464	Ex9PD2gy 6.3V AC/DC	2/162
2	green, yellow	102465	Ex9PD2gy 12V AC/DC	2/162
2	green, yellow	102466	Ex9PD2gy 24V AC/DC	2/162
2	green, yellow	102467	Ex9PD2gy 110V AC/DC	2/162
2	green, yellow	102468	Ex9PD2gy 230V AC/DC	2/162
2	green, blue	102469	Ex9PD2gb 6.3V AC/DC	2/162
2	green, blue	102470	Ex9PD2gb 12V AC/DC	2/162
2	green, blue	102471	Ex9PD2gb 24V AC/DC	2/162
2	green, blue	102472	Ex9PD2gb 110V AC/DC	2/162
2	green, blue	102473	Ex9PD2gb 230V AC/DC	2/162
2	green, white	102474	Ex9PD2gw 6.3V AC/DC	2/162
2	green, white	102475	Ex9PD2gw 12V AC/DC	2/162
2	green, white	102476	Ex9PD2gw 24V AC/DC	2/162
2	green, white	102477	Ex9PD2gw 110V AC/DC	2/162
2	green, white	102478	Ex9PD2gw 230V AC/DC	2/162

Signal lamps Ex9PD

2-LED version



No of LEDs	Colour	Article No.	Type	Packing
2	red, red	102479	Ex9PD2rr 6.3V AC/DC	2/162
2	red, red	102480	Ex9PD2rr 12V AC/DC	2/162
2	red, red	102481	Ex9PD2rr 24V AC/DC	2/162
2	red, red	102482	Ex9PD2rr 110V AC/DC	2/162
2	red, red	102483	Ex9PD2rr 230V AC/DC	2/162
2	red, yellow	102484	Ex9PD2ry 6.3V AC/DC	2/162
2	red, yellow	102485	Ex9PD2ry 12V AC/DC	2/162
2	red, yellow	102486	Ex9PD2ry 24V AC/DC	2/162
2	red, yellow	102487	Ex9PD2ry 110V AC/DC	2/162
2	red, yellow	102488	Ex9PD2ry 230V AC/DC	2/162
2	red, blue	102489	Ex9PD2rb 6.3V AC/DC	2/162
2	red, blue	102490	Ex9PD2rb 12V AC/DC	2/162
2	red, blue	102491	Ex9PD2rb 24V AC/DC	2/162
2	red, blue	102492	Ex9PD2rb 110V AC/DC	2/162
2	red, blue	102493	Ex9PD2rb 230V AC/DC	2/162
2	red, white	102494	Ex9PD2rw 6.3V AC/DC	2/162
2	red, white	102495	Ex9PD2rw 12V AC/DC	2/162
2	red, white	102496	Ex9PD2rw 24V AC/DC	2/162
2	red, white	102497	Ex9PD2rw 110V AC/DC	2/162
2	red, white	102498	Ex9PD2rw 230V AC/DC	2/162
2	yellow, yellow	102499	Ex9PD2yy 6.3V AC/DC	2/162
2	yellow, yellow	102500	Ex9PD2yy 12V AC/DC	2/162
2	yellow, yellow	102501	Ex9PD2yy 24V AC/DC	2/162
2	yellow, yellow	102502	Ex9PD2yy 110V AC/DC	2/162
2	yellow, yellow	102503	Ex9PD2yy 230V AC/DC	2/162
2	yellow, blue	102504	Ex9PD2yb 6.3V AC/DC	2/162
2	yellow, blue	102505	Ex9PD2yb 12V AC/DC	2/162
2	yellow, blue	102506	Ex9PD2yb 24V AC/DC	2/162
2	yellow, blue	102507	Ex9PD2yb 110V AC/DC	2/162
2	yellow, blue	102508	Ex9PD2yb 230V AC/DC	2/162
2	yellow, white	102509	Ex9PD2yw 6.3V AC/DC	2/162
2	yellow, white	102510	Ex9PD2yw 12V AC/DC	2/162
2	yellow, white	102511	Ex9PD2yw 24V AC/DC	2/162
2	yellow, white	102512	Ex9PD2yw 110V AC/DC	2/162
2	yellow, white	102513	Ex9PD2yw 230V AC/DC	2/162
2	blue, blue	102514	Ex9PD2bb 6.3V AC/DC	2/162
2	blue, blue	102515	Ex9PD2bb 12V AC/DC	2/162
2	blue, blue	102516	Ex9PD2bb 24V AC/DC	2/162
2	blue, blue	102517	Ex9PD2bb 110V AC/DC	2/162
2	blue, blue	102518	Ex9PD2bb 230V AC/DC	2/162
2	blue, white	102519	Ex9PD2bw 6.3V AC/DC	2/162
2	blue, white	102520	Ex9PD2bw 12V AC/DC	2/162
2	blue, white	102521	Ex9PD2bw 24V AC/DC	2/162
2	blue, white	102522	Ex9PD2bw 110V AC/DC	2/162
2	blue, white	102523	Ex9PD2bw 230V AC/DC	2/162
2	white, white	102524	Ex9PD2ww 6.3V AC/DC	2/162
2	white, white	102525	Ex9PD2ww 12V AC/DC	2/162
2	white, white	102526	Ex9PD2ww 24V AC/DC	2/162
2	white, white	102527	Ex9PD2ww 110V AC/DC	2/162
2	white, white	102528	Ex9PD2ww 230V AC/DC	2/162



Analogue Time Switches Ex9TA



- Installation Analogue Time Switches
- Operating voltage U_e 230 V AC
- Quartz or grid synchronous time basis
- Daily program of integrated time switch
- Shortest switching time 30 min.
- 1 or 3-module width versions

Installation Analogue Time Switches Ex9TA are suitable for residential and industrial applications. They will find their use everywhere where it is needed to save energy costs and to switch the circuit in regular daily cycles. Shortest switching time is 30 minutes.

Time switches are offered in 1 or 3-modules width versions with Quartz or grid synchronous time basis.

Type Key

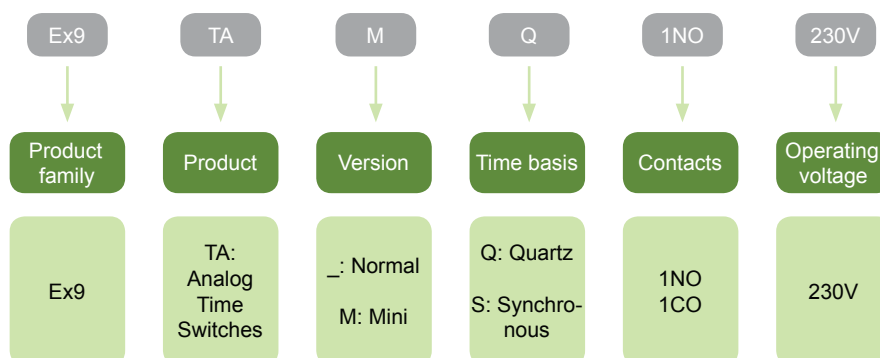

Certification marks



Analogue Time Switches Ex9TA

Analogue Time Switches - mini version

- Synchronous or Quartz time basis
- Daily switching program
- Shortest switching time 30 min.
- Width 1MU



Channels	Contacts	Time basis	Article No.	Type	Packing
1	1NO	Synchronous	103514	Ex9TAMS 1NO 230V	1
1	1NO	Quartz	103515	Ex9TAMQ 1NO 230V	1

Analogue Time Switches

- Quartz time base
- Daily switching program
- Shortest switching time 30 min.
- Width 3MU



Channels	Contacts	Time basis	Article No.	Type	Packing
1	1CO	Quartz	103516	Ex9TAQ 1CO 230V	1

Digital Time Switches Ex9TD



- Installation Digital Time Switches
- Weekly and Holiday switching program
- Switching status LCD display
- Quartz time base
- Auto summer and wintertime change
- Miniature (1MU) and standard (2MU) width versions

Installation Digital Time Switches Ex9TD are suitable for time control and switching in various residential and industrial applications. They are fully programmable in every 1 minute and they are working in weekly and holiday switching program.

With these properties, it is possible to set the switching pattern exactly to as required and save energy costs.

These Time Switches are offered in 1MU wide miniature version Ex9TDM and 2MU wide version Ex9TD which is available also with comfort functions as Ex9TDC.

To determine the current status and setting up the time switch each device is equipped with LCD display.

Type Key

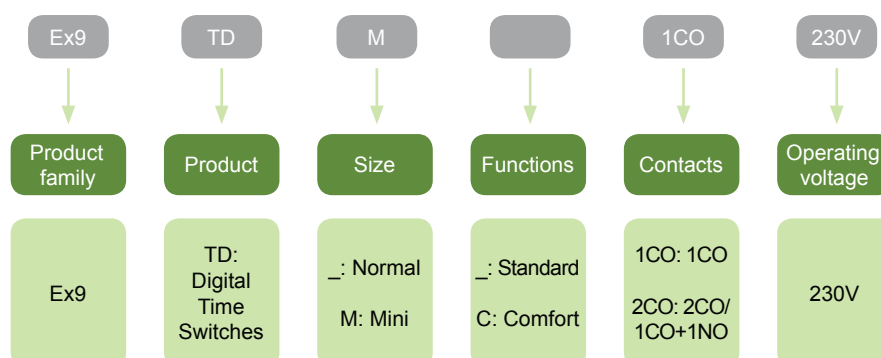

Certification marks



Digital Time Switches Ex9TD

Digital Time Switches - mini version

- Programmable every 1 min.
- Shortest switching time 1 min.
- Weekly and Holiday switching program
- Quartz time basis
- Width 1MU



Channels	Contacts	Comfort functions	Article No.	Type	Packing
1	1CO	-	103509	Ex9TDM 1CO 230V	1

Digital Time Switches

- Programmable every 1 min.
- Weekly and Holiday switching program, Free weekday block
- Backlighted switching state LCD display
- Quartz time basis
- Comfort functions (Ex9TDC): 100 memory spaces, random switching, external input, PC programming, 1 sec. shortest switching time, pulse and cycle switching program, 10 years power reserve, Astro program
- Width 2MU



Channels	Contacts	Comfort functions	Article No.	Type	Packing
1	1CO	-	103510	Ex9TD 1CO 230V	1
2	2CO	-	103511	Ex9TD 2CO 230V	1
1	1CO	yes	103512	Ex9TDC 1CO 230V	1
2	1CO + 1NO	yes	103513	Ex9TDC 2CO 230V	1

Staircase Switches Ex9SS



- Installation Staircase Switches
- Rated operating voltage 230 V AC
- Switching capacity up to 2300 W
- Time adjustment range from 0.5 to 20 min.
- Manual control switch

Installation Staircase Switches Ex9SS are suitable mainly for light switching in many various residential, office and industrial applications, e.g. lighting of staircases or entrance areas.

Their switching time can be adjusted up to 20 minutes using rotary switch on the front side, or they can be manually switched in ON state by the control slider.

Type Key

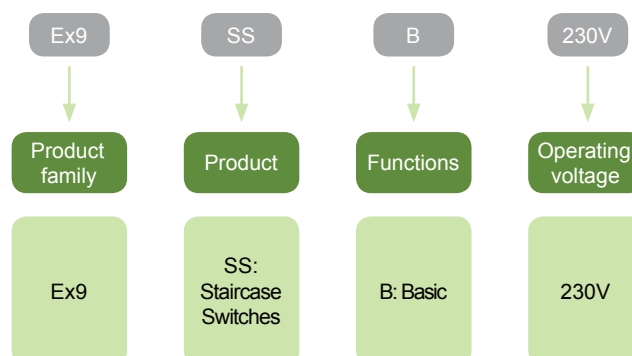

Certification marks



Staircase Switches Ex9SS

Staircase switches

- Time adjustment range from 0.5 to 20 minutes
- Manual control switch
- Switching capacity up to 2300 W
- Automatic recognition of 3 or 4-line connection
- Signal to input during ON status will reset adjusted time
- 100% duty of control circuit



Operating voltage U _e	Contacts	Functions	Article No.	Type	Packing
230 V AC	1 NO	Basic	103517	Ex9SSB 230V	1

Light Intensity Switches Ex9LA and Ex9LD



- Light Intensity Switches
- Rated operating voltage 230 V AC
- Analogue and digital version
- With 1 or 2 channels
- Without and with integrated time switch

Light Intensity Switches Ex9LA and Ex9LD are used for light switching according to actual daylight intensity (Ex9LD device also according to time), so the light fixtures are switched only if necessary and it can save money for consumed energy.

Analogue version works with one switching channel. Digital version can work with photoelectric and time switch on 2 channels. This switch can automatically change between summer and wintertime. It operates in weekly switching program and can be connect to light control systems with other devices.

External brightness sensor is included in the scope of delivery.

Type Key

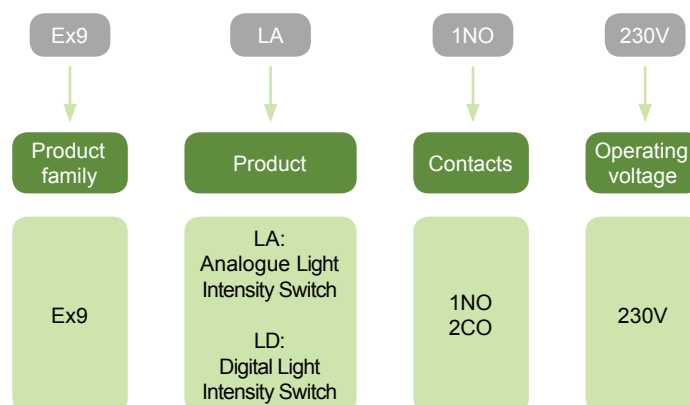

Certification marks



Light Intensity Switches Ex9LA and Ex9LD

Analogue version

- Fixed switching delay 100 sec.
- Light adjustment range 2 - 500 lx
- Surface-mounted brightness sensor in the scope of delivery



Channels	Width	Article No.	Type	Packing
1	1MU	103519	Ex9LA 1NO 230V	1

Technical data p. 173

Digital version

- Adjustable switching delay 0 to 100 sec.
- Light adjustment range 2 - 500 lx
- Up to 10 devices can be combined in one light control system with only one brightness sensor
- Weekly program of integrated time switch
- Surface-mounted brightness sensor in the scope of delivery



Channels	Width	Article No.	Type	Packing
2	3MU	103520	Ex9LD 2CO 230V	1

Technical data p. 175

Miniature Circuit Breakers	
Ex9BH MCBs up to 63 A, 10 kA	101
Ex9BN MCBs up to 63 A, 6 kA	104
Ex9B125 MCBs up to 125 A	107
Ex9PN 1P+N MCBs in one-module, 6 kA	111
Ex9BD DC MCBs up to 63 A	114
Isolators	
Ex9I125 Isolators up to 125 A	117
Ex9I40 Isolators up to 40 A in one-module	119
Ex9BI Isolators with accessories	121
Residual Current Devices	
Ex9CL-H RCCBs up to 63 A, 10 kA	123
Ex9CL-100 RCCBs up to 100 A, 10 kA	126
Ex9CL-N RCCBs up to 63 A, 6 kA	129
Ex9CBL-H RCBOs up to 40 A, 10 kA	132
Ex9CBL-N RCBOs up to 40 A, 6 kA	135
Ex9LE RCD add-on blocks	138
Accessories for installation devices	
Ex9B, Ex9PN accessories	141
Ex9CBL accessories	151
Surge Protection Devices	
Ex9UE1+2 SPDs class I+II	153
Ex9UE2 SPDs class II	154
Other devices	
Ex9CH20 Installation relays	159
Ex9CH Installation contactors	161
Ex9BT Change-over switches	163
Ex9PD Signal lamps	165
Ex9T Timers	167
Ex9SS Staircase switches	171
Ex9LA and Ex9LD Light intensity switches	173

Technical Data Ex9BH

Miniature Circuit Breakers, 10 kA

General parameters

Very high limiting of short circuit current		
Suitable for household as well as industrial applications		
Accessories		
Auxiliary contacts	AX3111, AX3122	100540, 100542
Alarm contact	AL3111	100541
Auxiliary and alarm contact	AXL31	100543
Shunt trip releases	SHT31, SHT3111	100544-100546, 100547-100549
Undervoltage releases	UVT31, UVT3101, UVT3110	100550-100551, 100552-100553, 100554-100555
Oversvoltage release	OVT31 280V AC±5%	100556
Max. number of installed accessories is 3 pcs of one contact units (AX3111, AL3111) or 2 pcs of two contact units (AX3122, AXL31) and 2 pcs of releases (SHT31, UVT31, OVT31)		
RCD add-on blocks	Ex9LE	

Electrical parameters

Tested according to	IEC/EN 60898-1
Rated op. voltage U_e	230/400 V AC
	48 V DC (per pole)
Minimum voltage	12 V AC/DC
Rated frequency	50/60 Hz
Rated breaking capacity I_{cn}	10 kA
Rated current	1 — 63 A
Tripping characteristics	B, C, D
Rated impulse withstand voltage U_{imp}	4 kV
Rated insulation voltage U_i	690 V AC
Mechanical service life	20 000 operation cycles
Electrical service life	10 000 operation cycles
Selectivity class	3
Max. back-up fuse	max. 125 A gG
Line voltage connection	arbitrary above or below

Mechanical parameters

Device width	18 mm (per pole)
Device height	83 mm (89 mm including rail clip)
Frame size	45 mm
Mounting	easy fastening onto 35 mm device rail (DIN)
Degree of protection	IP20
Terminals	combined lift + open mouthed
Terminal capacity	1 — 35 mm ²
Fastening torque of terminals	2 — 3.5 Nm
Busbar thickness	0.8 — 2 mm
Ambient temperature	-30 — +70 °C
Altitude	≤ 2000 m
Relative humidity	≤ 95 %
Resistance to humidity and heat	class 2
Pollution degree	2
Installation class	III
Weight	0.12 kg (per pole)

Technical Data Ex9BH

Miniature Circuit Breakers, 10 kA

Dimensions

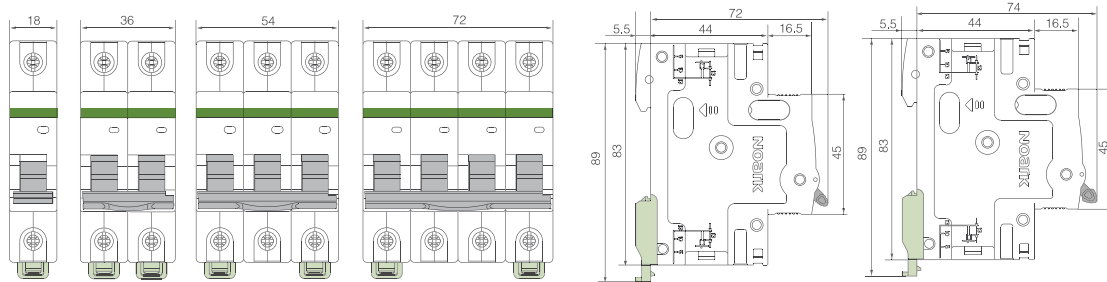

Wiring diagrams

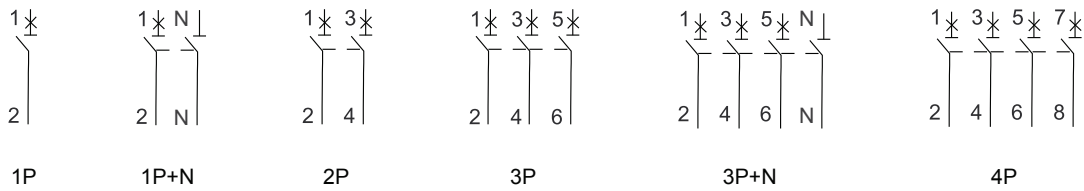

Tripping characteristics

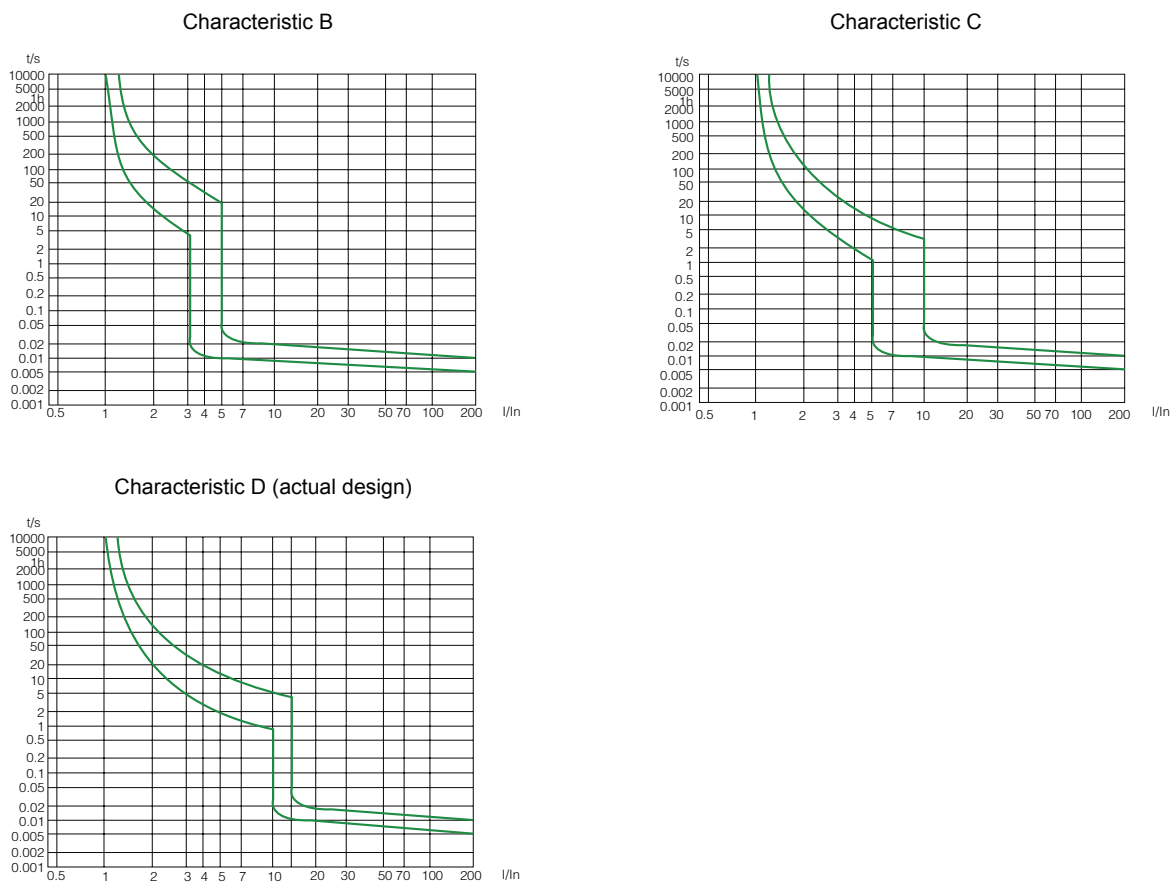

Technical Data Ex9BH

Miniature Circuit Breakers, 10 kA











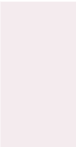

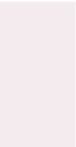

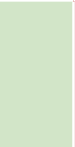
Dependence of Tripping Characteristics on Ambient Temperature

T [°C]	I_n (T) [A]														
	1 A	2 A	3 A	4 A	6 A	8 A	10 A	13 A	16 A	20 A	25 A	32 A	40 A	50 A	63 A
-30	1.3	2.5	3.8	5.1	7.6	10.2	13.6	16.8	20.5	25.3	31.1	40.5	51.0	64.0	82.0
-25	1.2	2.4	3.7	4.9	7.4	9.9	13.4	16.5	20.0	25.0	30.5	39.8	50.0	63.0	80.7
-20	1.2	2.4	3.6	4.8	7.3	9.7	13.1	16.3	19.8	24.5	30.0	39.2	49.2	62.0	79.2
-15	1.2	2.4	3.5	4.8	7.2	9.5	12.8	15.9	19.4	24.0	29.5	38.5	48.4	60.8	77.8
-10	1.2	2.3	3.5	4.7	7.1	9.3	12.5	15.7	19.0	23.7	29.0	37.9	47.5	59.8	76.3
-5	1.2	2.3	3.4	4.7	7.0	9.2	12.3	15.4	18.7	23.2	28.5	37.2	46.7	58.6	74.7
0	1.1	2.2	3.4	4.5	6.8	9.0	12.0	15.0	18.4	22.8	28.0	36.5	45.8	57.4	73.2
5	1.1	2.2	3.3	4.4	6.6	8.9	11.7	14.7	18.0	22.4	27.5	35.8	45.0	56.3	71.6
10	1.1	2.1	3.3	4.3	6.5	8.7	11.4	14.3	17.6	21.9	27.0	35.0	44.0	55.0	70.0
15	1.1	2.1	3.2	4.3	6.4	8.5	11.0	14.0	17.2	21.5	26.5	34.3	43.0	53.8	68.3
20	1.0	2.1	3.2	4.2	6.3	8.3	10.7	13.7	16.8	21.0	26.0	33.6	42.0	52.6	66.6
25	1.0	2.0	3.0	4.1	6.2	8.2	10.4	13.4	16.4	20.5	25.5	32.8	41.0	51.3	64.8
30	1	2	3	4	6	8	10	13	16	20	25	32	40	50	63
35	0.99	2.00	3.00	3.9	5.9	7.9	9.9	12.8	16.0	20.0	25.0	32.0	39.0	49.0	62.0
40	0.97	1.90	2.90	3.9	5.8	7.8	9.7	12.5	15.0	19.0	24.0	31.0	39.0	48.0	61.0
45	0.95	1.90	2.80	3.8	5.7	7.7	9.5	12.2	15.0	19.0	24.0	30.0	38.0	47.0	60.0
50	0.93	1.90	2.80	3.7	5.6	7.6	9.3	12.0	15.0	19.0	23.0	30.0	37.0	46.0	58.0
55	0.91	1.80	2.80	3.6	5.5	7.5	9.0	11.7	14.0	18.0	23.0	29.0	36.0	44.0	57.0
60	0.91	1.80	2.70	3.5	5.4	7.2	8.8	11.5	14.0	18.0	22.0	28.0	35.0	42.0	55.0
65	0.91	1.80	2.70	3.5	5.3	7.1	8.6	11.2	13.0	17.0	21.0	28.0	34.0	40.0	52.0
70	0.91	1.80	2.70	3.5	5.3	6.9	8.6	11.0	13.0	17.0	21.0	27.0	33.0	38.0	50.0

Power loss per pole

I_n [A]	1 A	2 A	3 A	4 A	6 A	8 A	10 A	13 A	16 A	20 A	25 A	32 A	40 A	50 A	63 A
P [W]	1.5	2.0	1.8	2.0	2.2	2.6	1.5	1.7	1.8	2.0	2.2	2.6	2.9	3.8	4.4

Toggle colours meaning

I_n [A]	1 A	2 A	3 A	4 A	6 A	8 A	10 A	13 A	16 A	20 A	25 A	32 A	40 A	50 A	63 A
Colour															

Technical Data Ex9BN

Miniature Circuit Breakers, 6 kA

General parameters

High limiting of short circuit current		
Suitable for household as well as industrial applications		
Accessories		
Auxiliary contacts	AX3111, AX3122	100540, 100542
Alarm contact	AL3111	100541
Auxiliary and alarm contact	AXL31	100543
Shunt trip releases	SHT31, SHT3111	100544-100546, 100547-100549
Undervoltage releases	UVT31, UVT3101, UVT3110	100550-100551, 100552-100553, 100554-100555
Oversvoltage release	OVT31 280V AC±5%	100556
Max. number of installed accessories is 3 pcs of one contact units (AX3111, AL3111) or 2 pcs of two contact units (AX3122, AXL31) and 2 pcs of releases (SHT31, UVT31, OVT31)		
RCD add-on blocks	Ex9LE	

Electrical parameters

Tested according to	IEC/EN 60898-1
Rated op. voltage U_e	230/400 V AC
	48 V DC (per pole)
Minimum voltage	12 V AC/DC
Rated frequency	50/60 Hz
Rated breaking capacity I_{cn}	6 kA
Rated current	1 — 63 A
Tripping characteristics	B, C, D
Rated impulse withstand voltage U_{imp}	4 kV
Rated insulation voltage U_i	690 V AC
Mechanical service life	20 000 operation cycles
Electrical service life	10 000 operation cycles
Selectivity class	3
Max. back-up fuse	max. 125 A gG
Line voltage connection	arbitrary above or below

Mechanical parameters

Device width	18 mm (per pole)
Device height	83 mm (89 mm including rail clip)
Frame size	45 mm
Mounting	easy fastening onto 35 mm device rail (DIN)
Degree of protection	IP20
Terminals	combined lift + open mouthed
Terminal capacity	1 — 35 mm ²
Fastening torque of terminals	2 — 3.5 Nm
Busbar thickness	0.8 — 2 mm
Ambient temperature	-30 — +70 °C
Altitude	≤ 2000 m
Relative humidity	≤ 95 %
Resistance to humidity and heat	class 2
Pollution degree	2
Installation class	III
Weight	0.12 kg (per pole)

Technical Data Ex9BN

Miniature Circuit Breakers, 6 kA

Dimensions

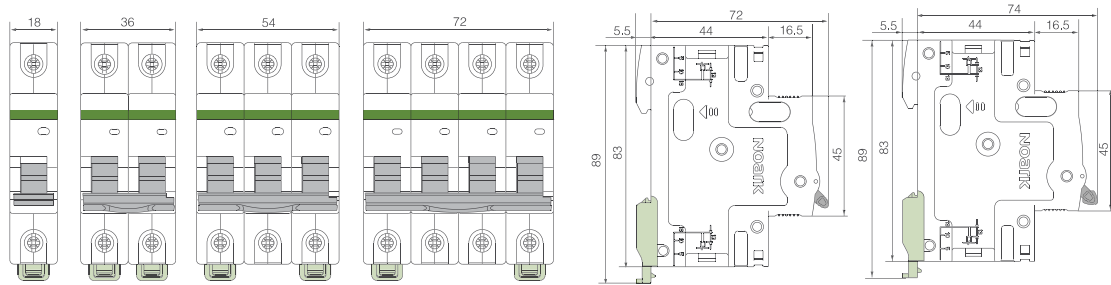

Wiring diagrams

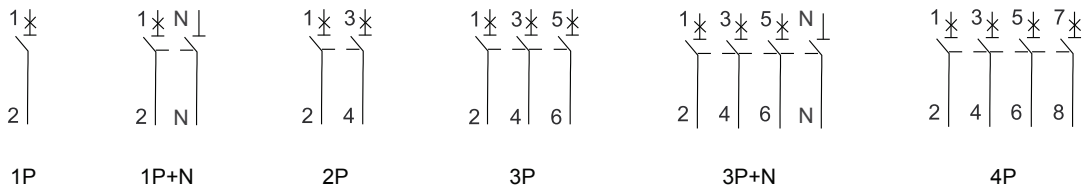

Tripping characteristics

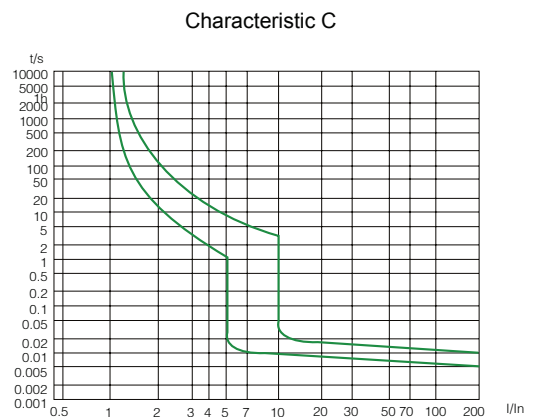
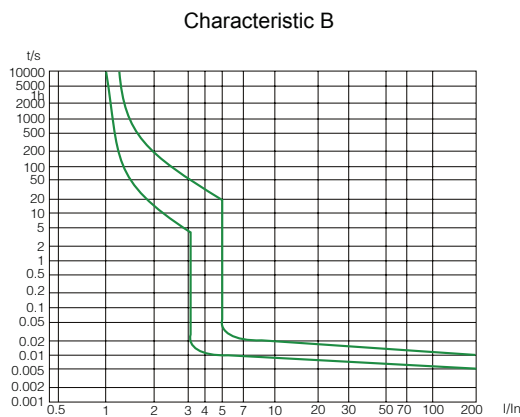

Characteristic D (actual design)

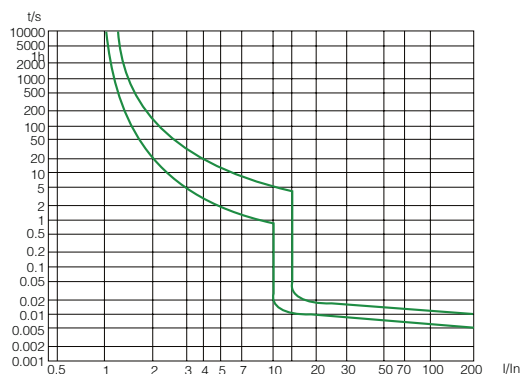

Technical Data Ex9BN

Miniature Circuit Breakers, 6 kA

Dependence of Tripping Characteristics on Ambient Temperature

T [°C]	I_n (T) [A]														
	1 A	2 A	3 A	4 A	6 A	8 A	10 A	13 A	16 A	20 A	25 A	32 A	40 A	50 A	63 A
-30	1.3	2.5	3.8	5.1	7.6	10.2	13.6	16.8	20.5	25.3	31.1	40.5	51.0	64.0	82.0
-25	1.2	2.4	3.7	4.9	7.4	9.9	13.4	16.5	20.0	25.0	30.5	39.8	50.0	63.0	80.7
-20	1.2	2.4	3.6	4.8	7.3	9.7	13.1	16.3	19.8	24.5	30.0	39.2	49.2	62.0	79.2
-15	1.2	2.4	3.5	4.8	7.2	9.5	12.8	15.9	19.4	24.0	29.5	38.5	48.4	60.8	77.8
-10	1.2	2.3	3.5	4.7	7.1	9.3	12.5	15.7	19.0	23.7	29.0	37.9	47.5	59.8	76.3
-5	1.2	2.3	3.4	4.7	7.0	9.2	12.3	15.4	18.7	23.2	28.5	37.2	46.7	58.6	74.7
0	1.1	2.2	3.4	4.5	6.8	9.0	12.0	15.0	18.4	22.8	28.0	36.5	45.8	57.4	73.2
5	1.1	2.2	3.3	4.4	6.6	8.9	11.7	14.7	18.0	22.4	27.5	35.8	45.0	56.3	71.6
10	1.1	2.1	3.3	4.3	6.5	8.7	11.4	14.3	17.6	21.9	27.0	35.0	44.0	55.0	70.0
15	1.1	2.1	3.2	4.3	6.4	8.5	11.0	14.0	17.2	21.5	26.5	34.3	43.0	53.8	68.3
20	1.0	2.1	3.2	4.2	6.3	8.3	10.7	13.7	16.8	21.0	26.0	33.6	42.0	52.6	66.6
25	1.0	2.0	3.0	4.1	6.2	8.2	10.4	13.4	16.4	20.5	25.5	32.8	41.0	51.3	64.8
30	1	2	3	4	6	8	10	13	16	20	25	32	40	50	63
35	0.99	2.00	3.00	3.9	5.9	7.9	9.9	12.8	16.0	20.0	25.0	32.0	39.0	49.0	62.0
40	0.97	1.90	2.90	3.9	5.8	7.8	9.7	12.5	15.0	19.0	24.0	31.0	39.0	48.0	61.0
45	0.95	1.90	2.80	3.8	5.7	7.7	9.5	12.2	15.0	19.0	24.0	30.0	38.0	47.0	60.0
50	0.93	1.90	2.80	3.7	5.6	7.6	9.3	12.0	15.0	19.0	23.0	30.0	37.0	46.0	58.0
55	0.91	1.80	2.80	3.6	5.5	7.5	9.0	11.7	14.0	18.0	23.0	29.0	36.0	44.0	57.0
60	0.91	1.80	2.70	3.5	5.4	7.2	8.8	11.5	14.0	18.0	22.0	28.0	35.0	42.0	55.0
65	0.91	1.80	2.70	3.5	5.3	7.1	8.6	11.2	13.0	17.0	21.0	28.0	34.0	40.0	52.0
70	0.91	1.80	2.70	3.5	5.3	6.9	8.6	11.0	13.0	17.0	21.0	27.0	33.0	38.0	50.0

Power loss per pole

I_n [A]	1 A	2 A	3 A	4 A	6 A	8 A	10 A	13 A	16 A	20 A	25 A	32 A	40 A	50 A	63 A
P [W]	1.5	2.0	1.8	2.0	2.2	2.6	1.5	1.7	1.8	2.0	2.2	2.6	2.9	3.8	4.4

Technical Data Ex9B125

Miniature Circuit Breakers up to 125 A

General parameters

Suitable for power distribution and industrial applications

Very high limiting of short circuit current

Accessories (same as for Ex9B MCBs)

Auxiliary contacts	AX3111, AX3122	100540, 100542
Alarm contact	AL3111	100541
Auxiliary and alarm contact	AXL31	100543
Shunt trip releases	SHT31, SHT3111	100544-100546, 100547-100549
Undervoltage releases	UVT31, UVT3101, UVT3110	100550-100551, 100552-100553, 100554-100555
Oversvoltage release	OVT31 280V AC±5%	100556

Max. number of installed accessories is 3 pcs of one contact units (AX3111, AL3111) or 2 pcs of two contact units (AX3122, AXL31) and 2 pcs of releases (SHT31, UVT31, OVT31)

Electrical parameters

Tested according to	EN 60947-2
Rated operating voltage U_e	230/400 V AC 48 V DC
Rated frequency	50/60 Hz
Rated current	16 — 125 A
Poles	1, 1+N, 2, 3, 3+N, 4
Tripping characteristics (EN 60898-1)	B, C, D
Rated ultimate short-circuit breaking capacity I_{cu} (EN 60947-2)	
16, 20, 25, 32, 40, 50, 63 A	25 kA
80, 100 A	20 kA
125 A	15 kA
Rated service short-circuit breaking capacity I_{cs} (EN 60947-2)	
16, 20, 25, 32, 40, 50, 63 A	20 kA
80, 100 A	15 kA
125 A	10 kA
Rated short-circuit breaking capacity I_{cn} (EN 60898-1)	
16, 20, 25, 32, 40, 50, 63 A	20 kA
80, 100 A	15 kA
125 A	10 kA
Rated impulse withstand voltage U_{imp}	8 kV
Rated insulation voltage U_i	690 V AC
Electrical service life	10 000 operating cycles
Utilization category	A
Selectivity class	3
Max. back-up fuse	200 A gG
Line voltage connection	arbitrary above or below

Technical Data Ex9B125

Miniature Circuit Breakers up to 125 A

Mechanical parameters

Device width	27 mm (per pole)
Device height	83 mm (89 mm including rail clip)
Frame size	45 mm
Mounting	easy fastening onto 35 mm device rail (DIN)
Degree of protection	IP20
Mechanical service life	20 000 operating cycles
Terminals	open mouthed
Terminal capacity	2.5 — 50 mm ²
Fastening torque of terminals	3.5 — 6 Nm
Ambient temperature	-30 — +70 °C
Altitude	≤ 2000 m
Relative humidity	≤ 95 %
Resistance to humidity and heat	class 2
Pollution degree	2
Installation class	III
Weight	approx 0.2 kg (per pole)

Dimensions

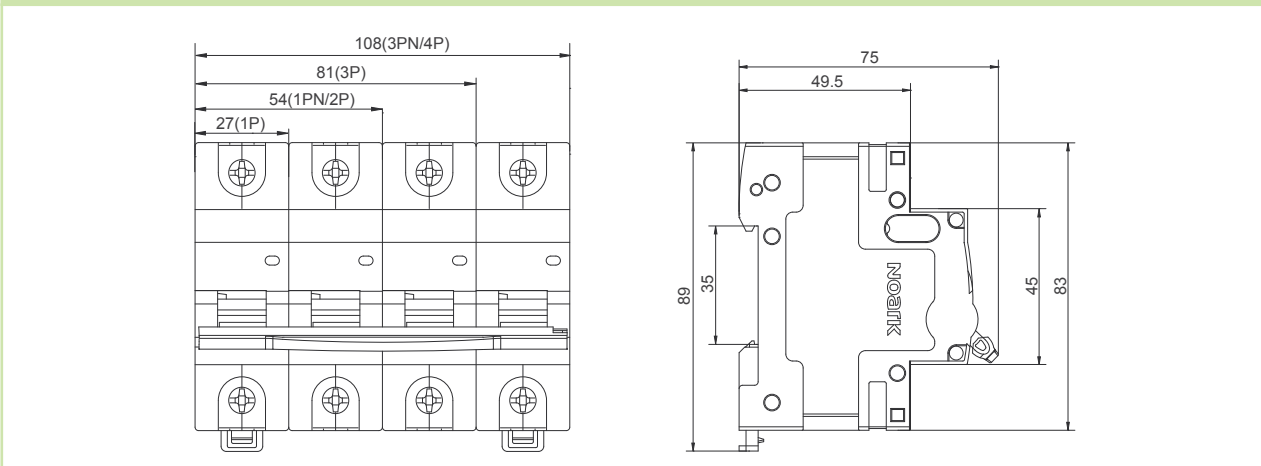

Wiring diagrams

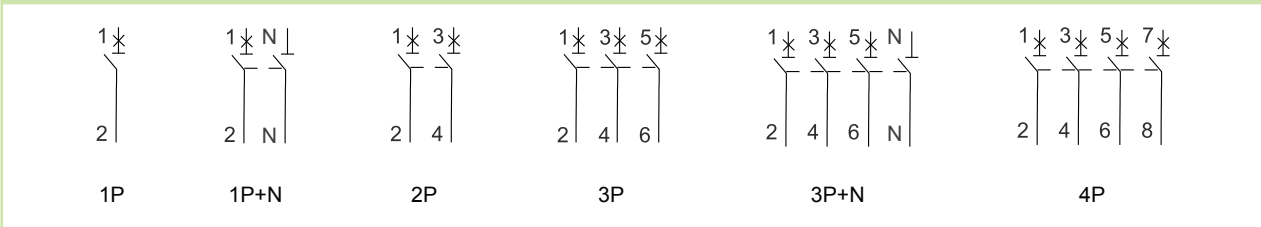

Technical Data Ex9B125

Miniature Circuit Breakers up to 125 A









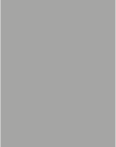

Dependence of Tripping Characteristics on Ambient Temperature

T [°C]	I_n (T) [A]									
	16 A	20 A	25 A	32 A	40 A	50 A	63 A	80 A	100 A	125 A
-30	20.5	25.3	31.1	40.5	51.3	64.2	82.1	105.2	132.6	164.3
-20	19.8	24.5	30.2	39.2	49.2	62.4	79.2	103.1	129.8	161.6
-10	19.0	23.7	29.6	37.9	47.5	59.8	76.3	99.1	124.0	154.2
0	18.4	22.8	28.2	36.5	45.8	57.4	73.2	94.9	118.1	146.8
10	17.6	21.9	27.7	35.0	44.3	55.4	70.0	90.3	113.3	140.2
20	16.8	21.0	26.1	33.6	42.0	52.6	66.6	86.7	108.2	134.9
30	16	20	25	32	40	50	63	80	100	125
40	15.4	19.3	24.5	31.4	39.2	48.7	61.6	75.8	94.2	117.5
50	15.0	18.8	23.2	30.9	37.6	46.2	58.8	71.3	89.6	111.7
60	14.2	18.1	22.1	28.6	35.8	42.6	55.4	67.9	85.1	106.3
70	13.5	17.7	20.6	27.5	33.1	38.3	50.5	66.3	82.2	101.9

Power loss per pole

I_n [A]	16 A	20 A	25 A	32 A	40 A	50 A	63 A	80 A	100 A	125 A
P [W]	2.1	2.5	2.9	3.1	3.8	4.4	5.6	6.7	7.7	10.7

Toggle colours meaning

I_n	16	20	25	32	40	50	63	80	100	125
Colour										

Technical Data Ex9B125

Miniature Circuit Breakers up to 125 A

Tripping characteristics

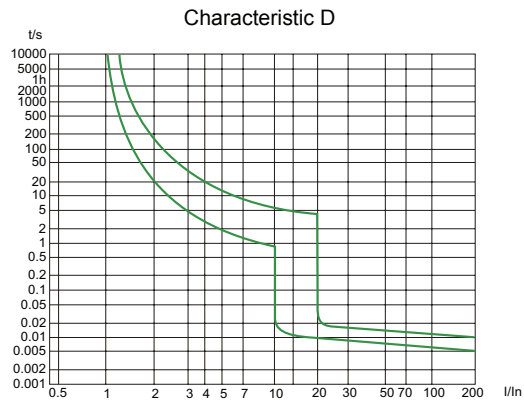
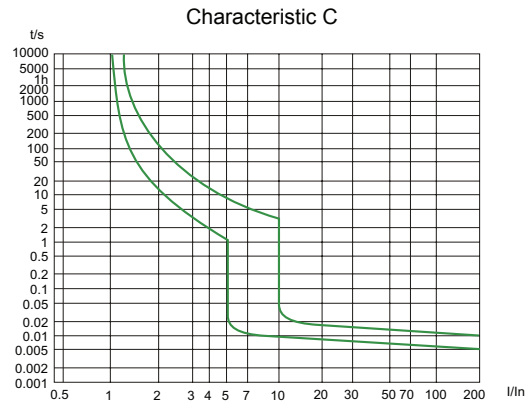
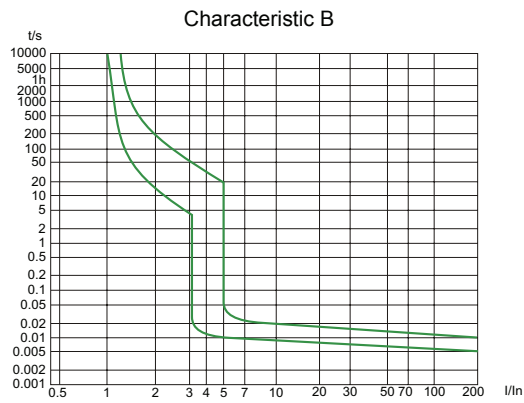

Technical Data Ex9PN-N

Miniature Circuit Breakers Ex9PN-N

General parameters

Very high limiting of short circuit current

1P+N pole circuit breaker in one module

Suitable for household as well as industrial applications

Accessories

Auxiliary contacts	AX3111, AX3122	100540, 100542
Alarm contact	AL3111	100541
Auxiliary and alarm contact	AXL31	100543
Shunt trip releases	SHT31, SHT3111	100544-100546, 100547-100549
Undervoltage releases	UVT31, UVT3101, UVT3110	100550-100551, 100552-100553, 100554-100555
Oversvoltage release	OVT31 280V AC±5%	100556
Max. number of installed accessories is 3 pcs of one contact units (AX3111, AL3111) or 2 pcs of two contact units (AX3122, AXL31) and 2 pcs of releases (SHT31, UVT31, OVT31)		

Electrical parameters

Tested according to	IEC/EN 60898-1
Rated op. voltage U_e	230 V AC
	48 V DC (per pole)
Minimum voltage	12 V AC/DC
Rated frequency	50/60 Hz
Rated breaking capacity I_{cn}	6 kA
Rated current	1 — 40 A
Tripping characteristics	B, C
Rated impulse withstand voltage U_{imp}	4 kV
Rated insulation voltage U_i	400 V AC
Mechanical service life	20 000 operation cycles
Electrical service life	10 000 operation cycles
Selectivity class	3
Max. back-up fuse	max. 125 A gG
Line voltage connection	arbitrary above or below

Mechanical parameters

Device width	18 mm
Device height	83 mm (89 mm including rail clip)
Frame size	45 mm
Mounting	easy fastening onto 35 mm device rail (DIN)
Degree of protection	IP20
Terminals	lift
Terminal capacity	1 — 16 mm ²
Ambient temperature	-30 — +70 °C
Altitude	≤ 2000 m
Relative humidity	≤ 95 %
Resistance to humidity and heat	class 2
Pollution degree	2
Installation class	III
Weight	0.12 kg

Technical Data Ex9PN-N

Miniature Circuit Breakers Ex9PN-N

Dimensions

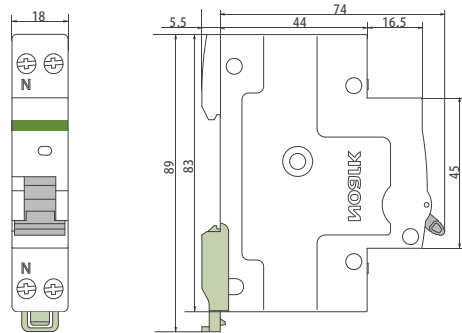

Wiring diagram

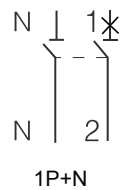

Tripping characteristics

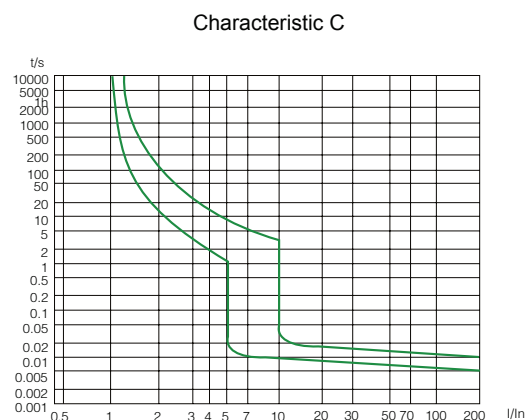
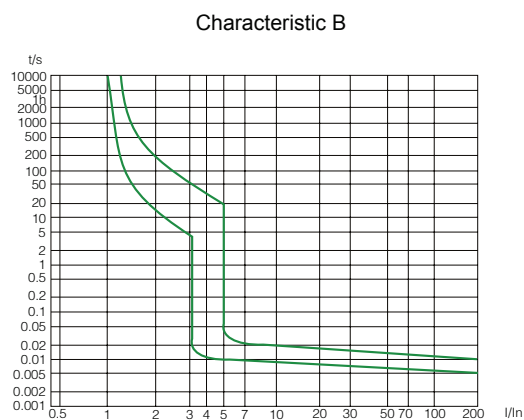

Technical Data Ex9PN-N

Miniature Circuit Breakers Ex9PN-N

Dependence of Tripping Characteristics on Ambient Temperature

T [°C]	$I_n(T)$ [A]										
	1 A	2 A	3 A	4 A	6 A	10 A	16 A	20 A	25 A	32 A	40 A
-20	1.35	2.6	4.1	5.3	8	13.5	20	24.5	29.8	39.5	50.5
-15	1.28	2.53	4.05	5.15	7.8	13.3	19.8	24.3	29.7	39.3	50.4
-10	1.25	2.4	3.95	5.08	7.6	13	19.5	24	29.5	39	50.2
-5	1.2	2.33	3.9	4.98	7.3	12.7	19.2	23.8	29.3	38.8	50
0	1.18	2.3	3.8	4.8	7.2	12.5	19.1	23.7	29.2	38.6	48.8
5	1.15	2.28	3.6	4.72	7	12.3	18.8	23.5	29	38.4	48.6
10	1.1	2.23	3.45	4.65	6.8	12.1	18.6	23.3	28.8	38.2	48.4
15	1.08	2.18	3.35	4.52	6.6	12	18.5	23.1	28.6	38	48.1
20	1.05	2.09	3.22	4.31	6.4	11.8	18.3	22.8	28.4	37.8	47.8
25	1.05	2.03	3.08	4.22	6.2	11.5	18	22.6	28.2	37.5	47
30	1	2	3	4	6	10	16	20	25	32	40
35	0.99	1.98	2.98	3.95	6	9.9	15.7	19.7	24.6	31.5	39.2
40	0.97	1.95	2.95	3.91	5.9	9.8	15.4	19.3	24.3	31.1	38.8
45	0.95	1.91	2.91	3.85	5.83	9.8	15.1	18.8	24	30.8	38.3
50	0.91	1.88	2.88	3.8	5.72	9.6	14.9	18.5	23.8	30.1	38
55	0.89	1.85	2.82	3.74	5.65	9.5	14.7	18.2	23.5	29.5	36.5
60	0.86	1.81	2.77	3.71	5.5	9	14.5	17.8	23	28.5	35
65	0.84	1.77	2.73	3.65	5.4	8.6	14	17.5	22	27.5	34
70	0.81	1.71	2.65	3.52	5.2	8	13.8	17.3	21.5	27	32.5

Technical Data Ex9BD

General purpose DC Miniature Circuit Breakers Ex9BD

General parameters

For general direct current applications

Polarity dependent - it is necessary to respect the polarity of the current

Accessories

Auxiliary contacts	AX3111, AX3122	100540, 100542
Alarm contact	AL3111	100541
Auxiliary and alarm contact	AXL31	100543
Shunt trip releases	SHT31, SHT3111	100544-100546, 100547-100549
Undervoltage releases	UVT31, UVT3101, UVT3110	100550-100551, 100552-100553, 100554-100555
Max. number of installed accessories is 3 pcs of one contact units (AX3111, AL3111) or 2 pcs of two contact units (AX3122, AXL31) and 2 pcs of releases (SHT31, UVT31)		

Electrical parameters

Tested according to	EN 60947-2
Rated op. voltage U_e	220 (1P), 440 (2P)
Rated ultimate breaking capacity I_{cu}	10 kA
Rated service breaking capacity I_{cs}	100% I_{cu}
Rated current I_n	1 — 63 A
Tripping characteristics	C, K
Rated impulse withstand voltage U_{imp}	6 kV
Rated insulation voltage U_i	800 V DC
Mechanical service life	20 000 operation cycles
Electrical service life	2 500 operation cycles
Selectivity class	3
Line voltage connection	necessary to follow marked polarity

Mechanical parameters

Device width	18 mm (per pole/module)
Device height	83 mm (89 mm including rail clip)
Frame size	45 mm
Mounting	easy fastening onto 35 mm device rail (DIN)
Degree of protection	IP20
Terminals	combined lift + open mouthed
Terminal capacity	1 — 35 mm ²
Fastening torque of terminals	2 — 3.5 Nm
Busbar thickness	0.8 — 2 mm
Ambient temperature	-20 — +70 °C
Altitude	≤ 5000 m
Relative humidity	≤ 95 %
Resistance to humidity and heat	class 2
Pollution degree	3
Installation class	III
Weight	0.12 kg (per pole/module)

Technical Data Ex9BD

General purpose DC Miniature Circuit Breakers Ex9BD

Dimensions

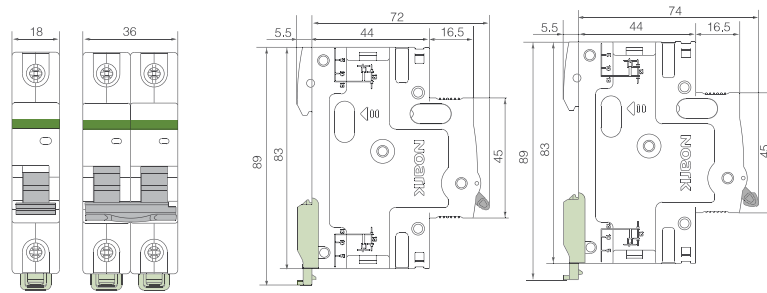

Wiring diagrams

DC220V

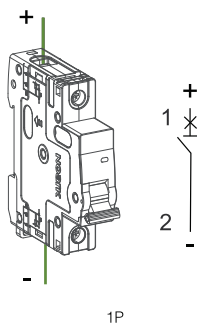

DC440V

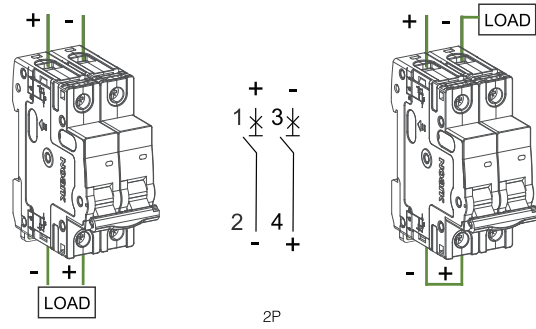

Tripping characteristics

Characteristic C

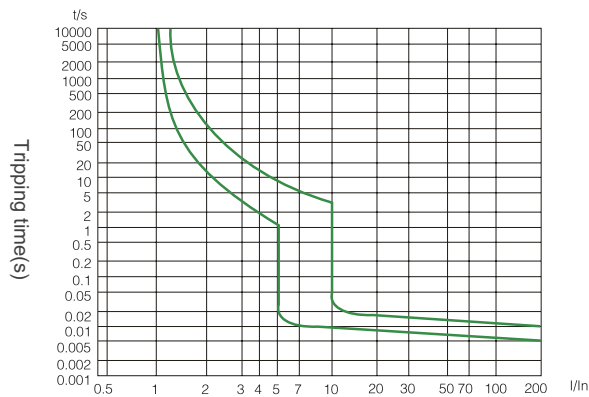

Characteristic K

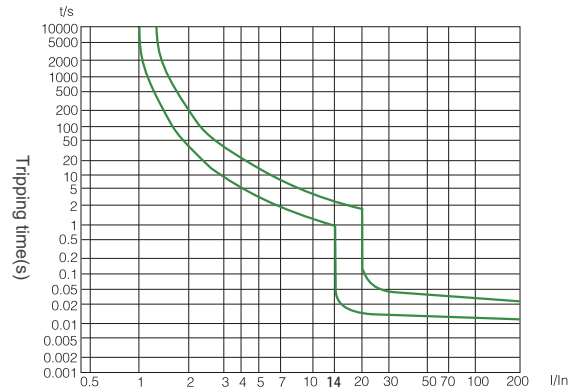

Technical Data Ex9BD

General purpose DC Miniature Circuit Breakers Ex9BD

Dependence of Tripping Characteristics on Ambient Temperature

T [°C]	I _n [A]												
	1 A	2 A	3 A	4 A	6 A	10 A	16 A	20 A	25 A	32 A	40 A	50 A	63 A
-30	1.3	2.5	3.8	5.1	7.6	13.6	20.5	25.3	31.1	40.5	51	64	82
-25	1.2	2.4	3.7	4.9	7.4	13.4	20	25	30.5	39.8	50	63	80.7
-20	1.2	2.4	3.6	4.8	7.3	13.1	19.8	24.5	30	39.2	49.2	62	79.2
-15	1.2	2.4	3.5	4.8	7.2	12.8	19.4	24	29.5	38.5	48.4	60.8	77.8
-10	1.2	2.3	3.5	4.7	7.1	12.5	19	23.7	29	37.9	47.5	59.8	76.3
-5	1.2	2.3	3.4	4.7	7	12.3	18.7	23.2	28.5	37.2	46.7	58.6	74.7
0	1.1	2.2	3.4	4.5	6.8	12	18.4	22.8	28	36.5	45.8	57.4	73.2
5	1.1	2.2	3.3	4.4	6.6	11.7	18	22.4	27.5	35.8	45	56.3	71.6
10	1.1	2.1	3.3	4.3	6.5	11.4	17.6	21.9	27	35	44	55	70
15	1.1	2.1	3.2	4.3	6.4	11	17.2	21.5	26.5	34.3	43	53.8	68.3
20	1	2.1	3.2	4.2	6.3	10.7	16.8	21	26	33.6	42	52.6	66.6
25	1	2	3	4.1	6.2	10.4	16.4	20.5	25.5	32.8	41	51.3	64.8
30	1	2	3	4	6	10	16	20	25	32	40	50	63
35	0.99	2	3	3.9	5.9	9.9	16	20	25	32	39	49	62
40	0.97	1.9	2.9	3.9	5.8	9.7	15	19	24	31	39	48	61
45	0.95	1.9	2.8	3.8	5.7	9.5	15	19	24	30	38	47	60
50	0.93	1.9	2.8	3.7	5.6	9.3	15	19	23	30	37	46	58
55	0.91	1.8	2.8	3.6	5.5	9	14	18	23	29	36	44	57
60	0.91	1.8	2.7	3.5	5.4	8.8	14	18	22	28	35	42	55
65	0.91	1.8	2.7	3.5	5.3	8.6	13	17	21	28	34	40	52
70	0.91	1.8	2.7	3.5	5.3	8.6	13	17	21	27	33	38	50

Power loss per pole

I _n [A]	1 A	2 A	3 A	4 A	6 A	10 A	16 A	20 A	25 A	32 A	40 A	50 A	63 A
P [W]	1.5	2.0	1.8	2.0	2.2	1.5	1.8	2.0	2.2	2.6	2.9	3.8	4.4

Technical Data Ex9I125

Isolators up to 125 A

General parameters

Modular design
Main switches with isolation function
Built-in lock mechanism for OFF position

Electrical parameters

Tested according to	IEC/EN 60947-3
Rated op. voltage	230/400 V AC
Rated frequency	50/60 Hz
Rated current I_e AC-22A 230/400 V AC	16, 25, 32, 40, 63, 80, 100, 125 A
Number of poles	1, 2, 3, 4
Utilization category	AC-22A
Rated insulation voltage U_i	500 V
Rated impulse withstand voltage U_{imp}	6 kV
Rated short-time withstand current I_{cw} , 1 s	$12 \times I_e$
Rated short-circuit making capacity I_{cm} $I_n = 16, 25, 32$ A $I_n = 40, 63$ A $I_n = 80, 100, 125$ A	640 A 1 260 A 2 500 A
Maximum back-up fuse	160 A gG
Mechanical service life	20 000 operation cycles
Electrical service life	4 000 operation cycles

Mechanical parameters

Device width	18 mm (per pole)
Device height	83 mm (89 mm including rail clip)
Frame size	45 mm
Mounting	easy fastening onto 35 mm device rail (DIN)
Degree of protection	IP40, terminals IP20
Terminals	combined lift + open mouthed
Terminal capacity	10 — 50 mm ²
Fastening torque of terminals	2 — 3.5 Nm
Busbar thickness	0.8 — 2 mm
Ambient temperature	-30 — +70 °C
Altitude	≤ 2000 m
Relative humidity	≤ 95 %
Resistance to humidity and heat	class 2
Pollution degree	2
Installation class	III
Weight	0.09 kg per pole

Technical Data Ex9I125

Isolators up to 125 A

Dimensions

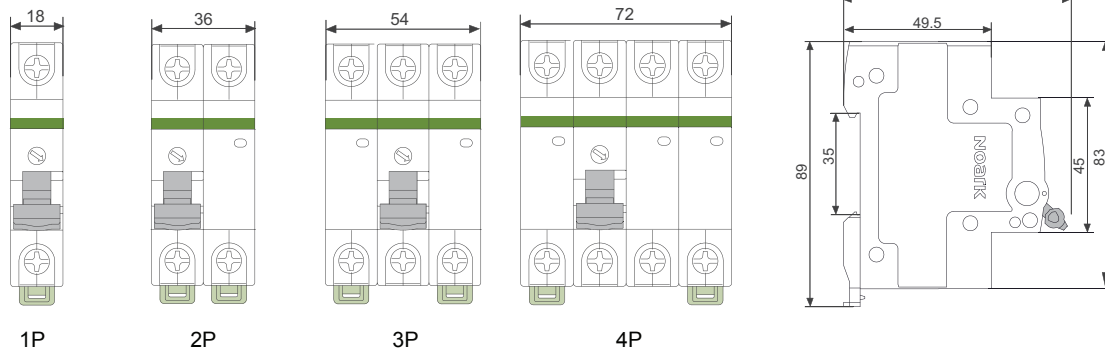

Wiring diagrams

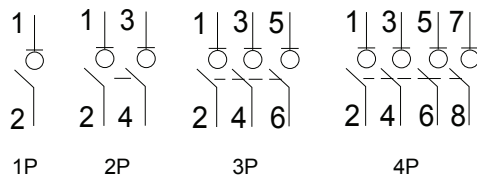

Technical Data Ex9I40

Isolators up to 40 A

General parameters

Modular design, width 1 MU only up to 4-pole version
Main switches with isolation function
Built-in lock mechanism for OFF position

Electrical parameters

Tested according to	IEC/EN 60947-3
Rated op. voltage	230/400 V AC
Rated frequency	50/60 Hz
Rated current I_e AC-22A 230/400 V AC	16, 25, 32, 40 A
Number of poles	1, 2, 3, 4
Utilization category	AC-22A
Rated insulation voltage U_i	500 V
Rated impulse withstand voltage U_{imp}	6 kV
Rated short-time withstand current I_{cw} , 1 s	$12 \times I_e$
Rated short-circuit making capacity I_{cm}	$20 \times I_e$ (0.1 s)
Maximum back-up fuse	50 A gG
Mechanical service life	20 000 operation cycles
Electrical service life	4 000 operation cycles

Mechanical parameters

Device width	18 mm for all versions
Device height	83 mm (89 mm including rail clip)
Frame size	45 mm
Mounting	easy fastening onto 35 mm device rail (DIN)
Degree of protection	IP40, terminals IP20
Terminals	lift
Terminal capacity	1 — 10 mm ²
Fastening torque of terminals	1 — 1.5 Nm
Ambient temperature	-30 — +70 °C
Altitude	≤ 2000 m
Relative humidity	≤ 95 %
Resistance to humidity and heat	class 2
Pollution degree	2
Installation class	III
Weight	0.06 kg

Technical Data Ex9I40

Isolators up to 40 A

Dimensions

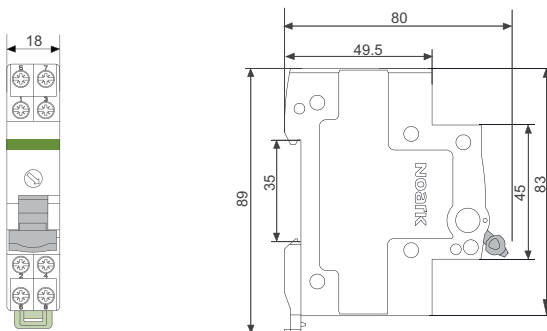

Wiring diagrams

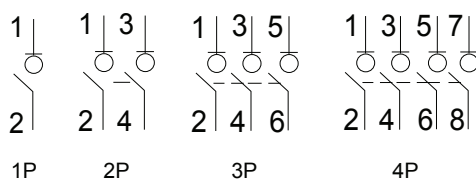

Technical Data Ex9BI

Isolators up to 63 A with Accessories

General parameters

Modular Isolators		
Usable as main switches with isolation function		
Suitable for household as well as industrial applications		
Accessories		
Auxiliary contacts	AX3111, AX3122	100540, 100542
Shunt trip releases	SHT31, SHT3111	100544-100546, 100547-100549
Undervoltage releases	UVT31, UVT3101, UVT3110	100550-100551, 100552-100553, 100554-100555
Overvoltage release	OVT31 280V AC±5%	100556
Max. number of installed accessories is 3 pcs of one contact units (AX3111) or 2 pcs of two contact units (AX3122) and 2 pcs of releases (SHT31, UVT31, OVT31)		

Electrical parameters

Tested according to	IEC/EN 60947-3
Rated op. voltage	230/400 V AC
Rated frequency	50 Hz
Rated current I_e AC-22A 230/400 V AC	16, 25, 32, 40, 63 A
Number of poles	1, 2, 3, 4
Utilization category	AC-22A
Rated insulation voltage U_i	690 V
Rated impulse withstand voltage U_{imp}	6 kV
Rated short-time withstand current I_{cw} , 1 s	1 kA
Rated short-circuit making capacity I_{cm}	1.5 kA
Maximum back-up fuse	125 A gG
Mechanical service life	20 000 operation cycles
Electrical service life	10 000 operation cycles

Mechanical parameters

Device width	18 mm (per pole)
Device height	83 mm (89 mm including rail clip)
Frame size	45 mm
Mounting	easy fastening onto 35 mm device rail (DIN)
Degree of protection	IP20
Terminals	combined lift + open mouthed
Terminal capacity	10 — 50 mm ²
Fastening torque of terminals	2 — 3,5 Nm
Busbar thickness	0,8 — 2 mm
Ambient temperature	-30 — +70 °C
Altitude	≤ 2000 m
Relative humidity	≤ 95 %
Resistance to humidity and heat	class 2
Pollution degree	2
Installation class	III
Weight	0.09 kg per pole

Technical Data Ex9BI

Isolators up to 63 A with Accessories

Dimensions

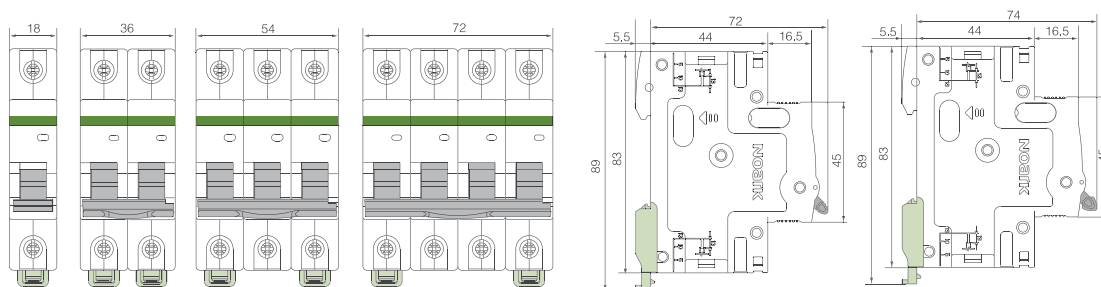

Wiring diagrams

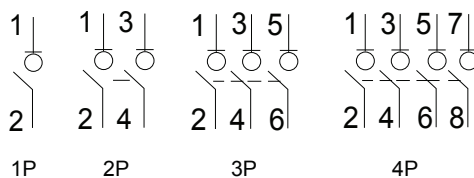

Technical Data Ex9CL-H

Residual Current Circuit Breakers, 10 kA

General parameters

Permanent magnet principle - Voltage independent tripping function
Suitable for household as well as industrial applications
AC and A types
Magnetic RCCBs should be tested regularly with a period of one month. This is a responsibility of the user of an installaton given by law
In case all wires are not connected at 4-pole RCCB, it is necessary to ensure that circuit of the test button T is supplied with appropriate voltage (by means of mutual connection of respective terminals of the RCCB, see wiring diagram)
Indication of electrical tripping

Electrical parameters

Tested according to	IEC/EN 61008
Rated op. voltage U_e	230/400 V AC
Min. voltage for RCD function	voltage independent
Voltage range of the test button T	150 — 254 V AC (2-pole), 150 — 440 V AC (4-pole)
Rated frequency	50/60 Hz
Conditional short circuit strength I_{nc}	10 kA
Rated current	25, 40, 63 A
Rated residual current	30, 100, 300 mA
Sensitivity to residual current	AC type - AC residual current A type - residual AC and pulsating DC current
Time characteristic	undelayed type
Rated impulse withstand voltage U_{imp}	6 kV
Rated insulation voltage U_i	500 V
Surge current proof	250 A
Mechanical service life	20 000 operation cycles
Electrical service life	4 000 operation cycles
Back-up fuse for overload	
$I_n = 25$ A	max. 25 A gG
$I_n = 40$ A	max. 32 A gG
$I_n = 63$ A	max. 50 A gG
Back-up fuse for short circuit	
$I_n = 25$ A	max. 63 A gG
$I_n = 40$ A	max. 63 A gG
$I_n = 63$ A	max. 63 A gG
Rated making capacity I_m (rated residual making capacity $I_{\Delta m}$)	
$I_n = 25$ A	500 A
$I_n = 40$ A	500 A
$I_n = 63$ A	630 A
Line voltage connection	arbitrary above or below

Technical Data Ex9CL-H

Residual Current Circuit Breakers, 10 kA

Mechanical parameters

Device width	36 mm (2-pole), 72 mm (4-pole)
Device height	85 mm including rail clip
Frame size	45 mm
Mounting	easy fastening onto 35 mm device rail (DIN)
Degree of protection	IP20
Terminals	combined lift + open mouthed
Terminal capacity	1 — 35 mm ²
Fastening torque of terminals	1.5 — 2.5 Nm
Busbar thickness	0.8 — 2 mm
Ambient temperature	-5 — +40 °C
Altitude	≤ 2000 m
Relative humidity	≤ 95 %
Resistance to humidity and heat	class 2
Pollution degree	2
Installation class	III
Weight	0.22 kg (2-pole), 0.4 kg (4-pole)

Dimensions

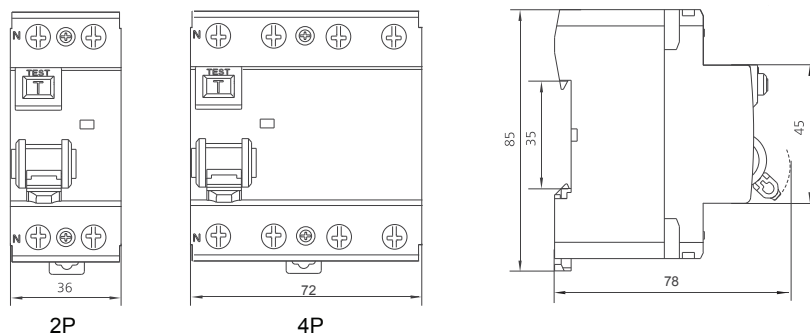

Wiring diagrams

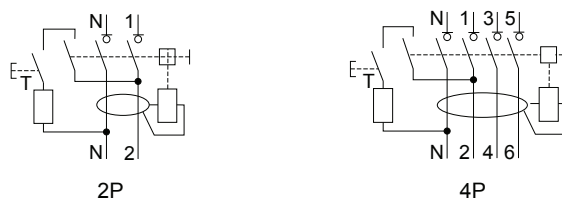

Technical Data Ex9CL-H

Residual Current Circuit Breakers, 10 kA

Tripping characteristics

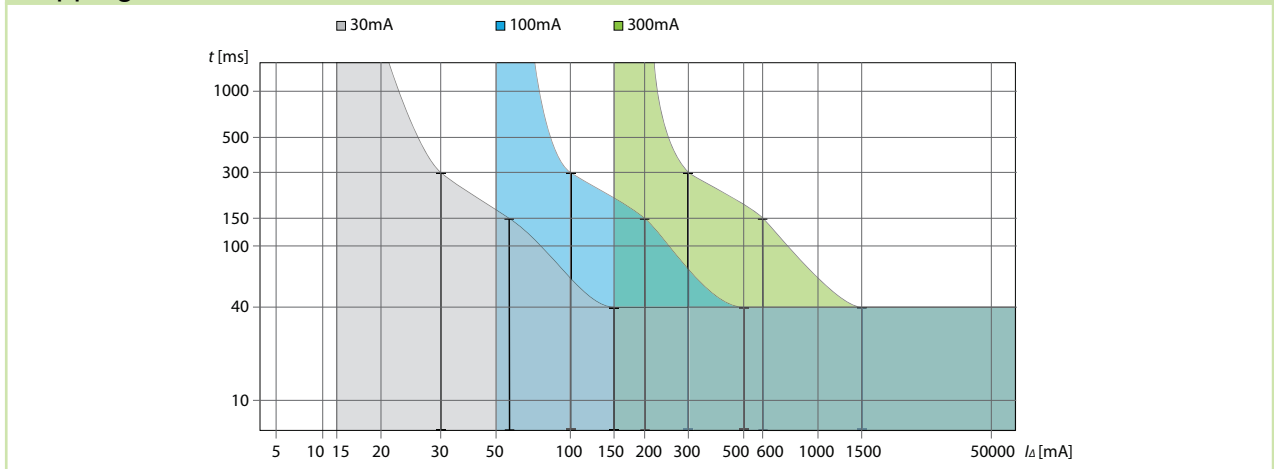

Power loss

I_n [A]	25 A			40 A			63 A			
	I_{Δ} [mA]	30 mA	100 mA	300 mA	30 mA	100 mA	300 mA	30 mA	100 mA	300 mA
P [W]	2P	3.0	2.7	1.7	6.9	6.7	5.2	9.7	7.2	7.2
	4P	4.0	3.8	2.7	11.2	10.6	7.5	14.7	13.3	11.7

Technical Data Ex9CL-100

Residual Current Circuit Breakers up to 100 A, 10 kA

General parameters

Permanent magnet principle - Voltage independent tripping function

Suitable for household as well as industrial applications

S and S+A types

Magnetic RCCBs should be tested regularly with a period of one month. This is a responsibility of the user of an installation given by law

In case all wires are not connected at 4-pole RCCB, it is necessary to ensure that circuit of the test button T is supplied with appropriate voltage (by means of mutual connection of respective terminals of the RCCB, see wiring diagram)

Indication of electrical tripping

Electrical parameters

Tested according to	IEC/EN 61008
Rated op. voltage U_e	230/400 V AC
Min. voltage for RCD function	voltage independent
Voltage range of the test button T	150 — 254 V AC (2-pole), 150 — 440 V AC (4-pole)
Rated frequency	50/60 Hz
Conditional short circuit strength I_{nc}	10 kA
Rated current	63, 80, 100 A
Rated residual current	100, 300 mA
Sensitivity to residual current	AC type - AC residual current A type - residual AC and pulsating DC current
Time characteristic	selective S type with insensitivity 40 ms
Rated impulse withstand voltage U_{imp}	6 kV
Rated insulation voltage U_i	500 V
Surge current proof	3000 A
Mechanical service life	20 000 operation cycles
Electrical service life	4 000 operation cycles
Back-up fuse for overload	
$I_n = 63$ A	max. 50 A gG
$I_n = 80$ A	max. 63 A gG
$I_n = 100$ A	max. 80 A gG
Back-up fuse for short circuit	
$I_n = 63$ A	max. 63 A gG
$I_n = 80$ A	max. 80 A gG
$I_n = 100$ A	max. 100 A gG
Rated making capacity I_m (rated residual making capacity $I_{\Delta m}$)	
$I_n = 63$ A	630 A
$I_n = 80$ A	1000 A
$I_n = 100$ A	1000 A
Line voltage connection	arbitrary above or below

Technical Data Ex9CL-100

Residual Current Circuit Breakers up to 100 A, 10 kA

Mechanical parameters

Device width	36 mm (2-pole), 72 mm (4-pole)
Device height	85 mm including rail clip
Frame size	45 mm
Mounting	easy fastening onto 35 mm device rail (DIN)
Degree of protection	IP20
Terminals	lift
Terminal capacity	1 — 35 mm ²
Fastening torque of terminals	1.5 — 2.5 Nm
Ambient temperature	-5 — +40 °C
Altitude	≤ 2000 m
Relative humidity	≤ 95 %
Resistance to humidity and heat	class 2
Pollution degree	2
Installation class	III
Weight	0.22 kg (2-pole), 0.4 kg (4-pole)

Dimensions

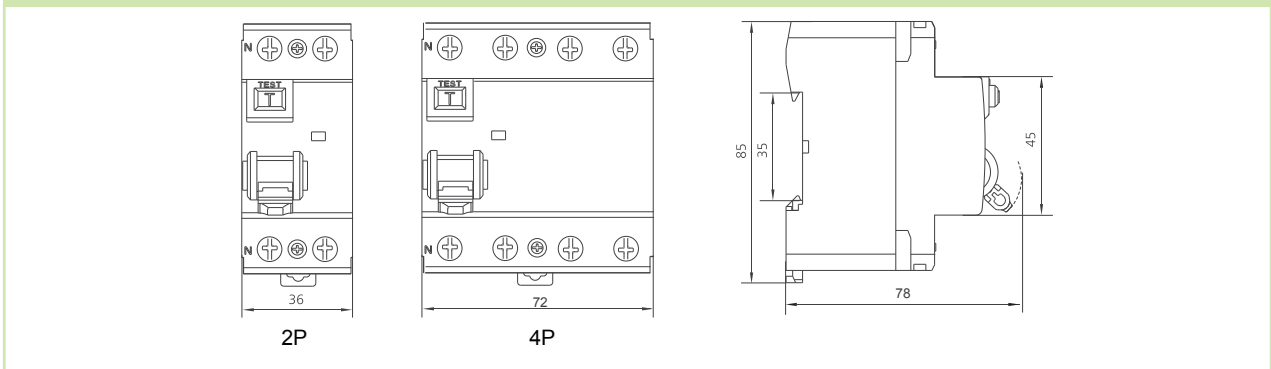

Wiring diagrams

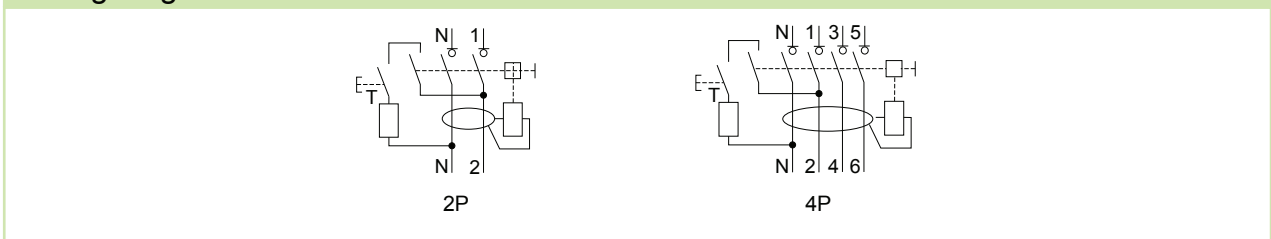

Technical Data Ex9CL-100

Residual Current Circuit Breakers up to 100 A, 10 kA

Tripping characteristics

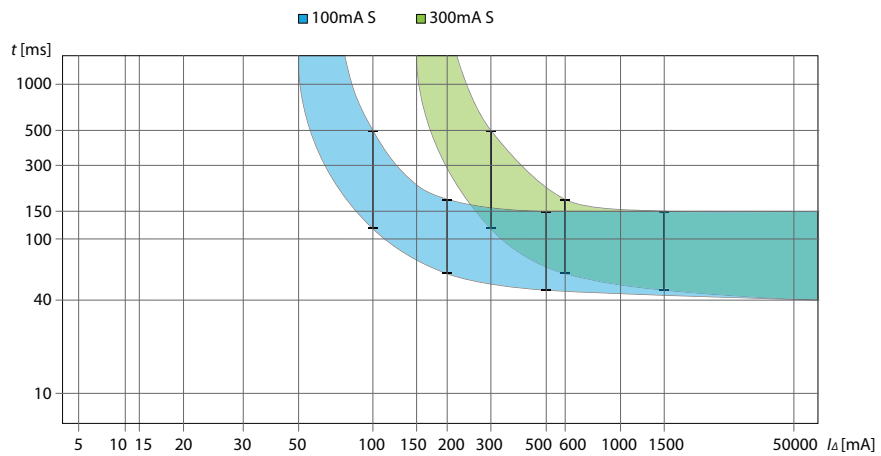

Power loss

I_n [A]		63 A		80 A		100 A	
I_{Δ} [mA]		100 mA	300 mA	100 mA	300 mA	100 mA	300 mA
P [W]	2P	7.2	7.2	8.3	8.1	10.5	10.1
	4P	13.3	11.7	14.5	14.2	17.7	16.9

Technical Data Ex9CL-N

Residual Current Circuit Breakers, 6 kA

General parameters

Permanent magnet principle - Voltage independent tripping function
Suitable for household as well as industrial applications
AC type
Magnetic RCCBs should be tested regularly with a period of one month. This is a responsibility of the user of an installaton given by law
In case all wires are not connected at 4-pole RCCB, it is necessary to ensure that circuit of the test button T is supplied with appropriate voltage (by means of mutual connection of respective terminals of the RCCB, see wiring diagram)
Indication of electrical tripping

Electrical parameters

Tested according to	IEC/EN 61008
Rated op. voltage U_e	240/415 V AC
Min. voltage for RCD function	voltage independent
Voltage range of the test button T	150 — 254 V AC (2-pole), 150 — 440 V AC (4-pole)
Rated frequency	50 Hz
Conditional short circuit strength I_{nc}	6 kA
Rated current	25, 40, 63 A
Rated residual current	30, 300 mA
Sensitivity to residual current	AC type - AC residual current
Time characteristic	undelayed type
Rated impulse withstand voltage U_{imp}	6 kV
Rated insulation voltage U_i	500 V
Surge current proof	250 A
Mechanical service life	20 000 operation cycles
Electrical service life	4 000 operation cycles
Back-up fuse for overload	
$I_n = 25$ A	max. 25 A gG
$I_n = 40$ A	max. 32 A gG
$I_n = 63$ A	max. 50 A gG
Back-up fuse for short circuit	
$I_n = 25$ A	max. 63 A gG
$I_n = 40$ A	max. 63 A gG
$I_n = 63$ A	max. 63 A gG
Rated making capacity I_m (rated residual making capacity $I_{\Delta m}$)	
$I_n = 25$ A	500 A
$I_n = 40$ A	500 A
$I_n = 63$ A	630 A
Line voltage connection	arbitrary above or below

Technical Data Ex9CL-N

Residual Current Circuit Breakers, 6 kA

Mechanical parameters

Device width	36 mm (2-pole), 72 mm (4-pole)
Device height	85 mm including rail clip
Frame size	45 mm
Mounting	easy fastening onto 35 mm device rail (DIN)
Degree of protection	IP20
Terminals	combined lift + open mouthed
Terminal capacity	1 — 35 mm ²
Fastening torque of terminals	1.5 — 2.5 Nm
Busbar thickness	0.8 — 2 mm
Ambient temperature	-5 — +40 °C
Altitude	≤ 2000 m
Relative humidity	≤ 95 %
Resistance to humidity and heat	class 2
Pollution degree	2
Installation class	III
Weight	0.22 kg (2-pole), 0.4 kg (4-pole)

Dimensions

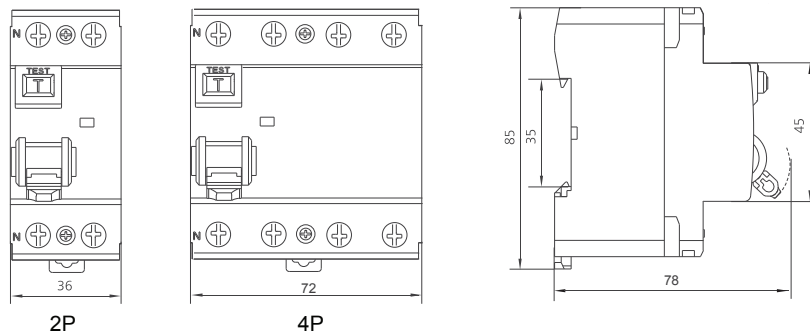

Wiring diagrams

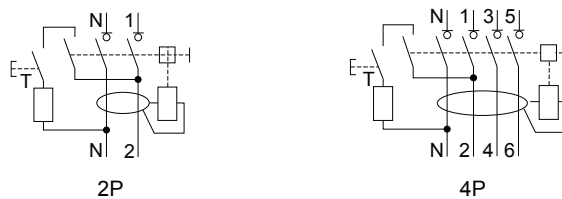

Technical Data Ex9CL-N

Residual Current Circuit Breakers, 6 kA

Tripping characteristics

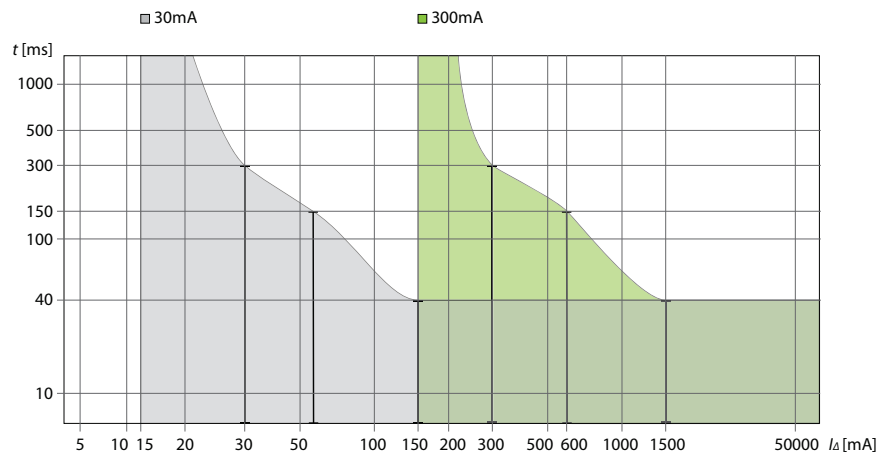

Power loss

I_n [A]	25 A	40 A		63 A		
I_Δ [mA]	30 mA	30 mA	300 mA	30 mA	300 mA	
P [W]	2P	3.0	6.9	5.2	-	-
	4P	4.0	11.2	7.6	13.3	11.7

Technical Data Ex9CBL-H

Residual Current Breakers with Overload protection Ex9CBL-H, 10 kA

General parameters

Combination of MCB and RCCB in one case - saves 50 % space in comparison to combination of stand-alone MCB and RCCB
Tripping characteristics of installed circuit breaker B and C
AC and A type of residual current device
1+N-pole version
Suitable for household as well as industrial applications
Permanent magnet principle of residual current device - Voltage independent tripping function
Magnetic RCBOs should be tested regularly with a period of one month. This is a responsibility of the user of an installation given by law
Signaling of contacts status

Electrical parameters

Tested according to	IEC/EN 61009
Rated op. voltage U_e	230 V AC
Min. voltage for RCD function	voltage independent
Voltage range of the test button T	110 — 254 V AC
Rated frequency	50/60 Hz
Rated breaking capacity I_{cn}	10 kA
Rated current	6 — 40 A
Rated residual current	30, 100, 300 mA
Sensitivity to residual current	AC type - AC residual current A type - residual AC and pulsating DC current
Time characteristic of RCD	undelayed type
Tripping characteristics of MCB	B, C
Rated impulse withstand voltage U_{imp}	4 kV
Rated insulation voltage U_i	500 V
Mechanical service life	20 000 operation cycles
Electrical service life	4 000 operation cycles
Selectivity class	3
Back-up fuse/breaker	max. 125 A gG
Line voltage connection	arbitrary above or below

Mechanical parameters

Device width	36 mm
Device height	85 mm including rail clip)
Frame size	45 mm
Mounting	easy fastening onto 35 mm device rail (DIN)
Degree of protection	IP20
Terminals	combined lift + open mouthed
Terminal capacity	1 — 35 mm ²
Fastening torque of terminals	1.5 — 2.5 Nm
Busbar thickness	0.8 — 2 mm
Ambient temperature	-25 — +40 °C
Altitude	≤ 2000 m
Relative humidity	≤ 95 %
Resistance to humidity and heat	class 2
Pollution degree	2
Installation class	III
Weight	0.2 kg

Technical Data Ex9CBL-H

Residual Current Breakers with Overload protection Ex9CBL-H, 10 kA

Dimensions

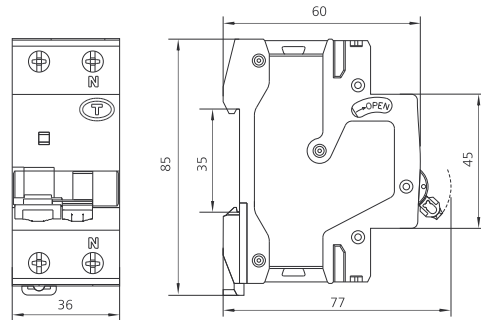

Wiring diagram

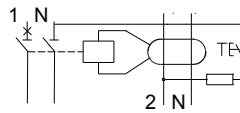

1P+N

Tripping characteristics of MCB

Characteristic B

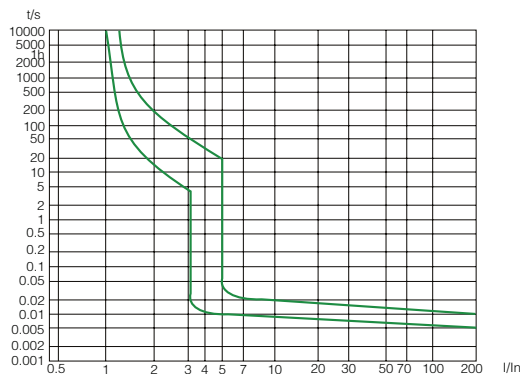

Characteristic C

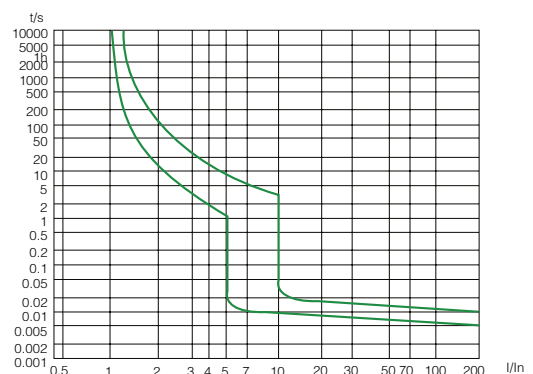

Tripping characteristics of RCD

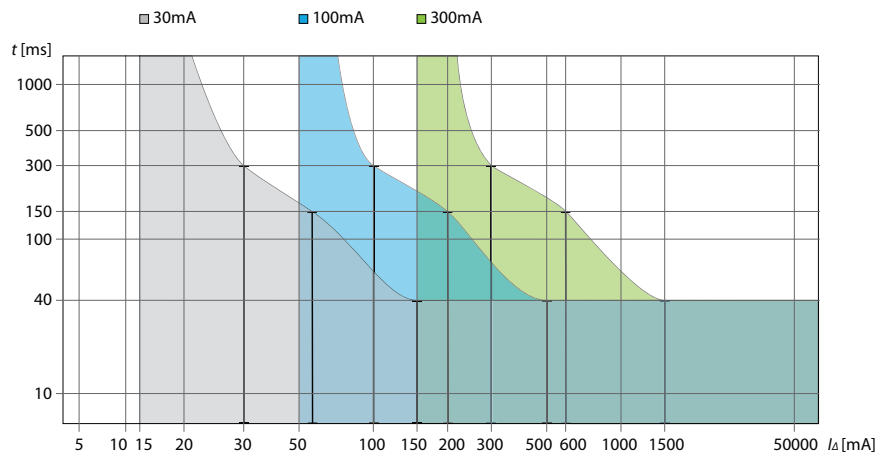

Technical Data Ex9CBL-H

Residual Current Breakers with Overload protection Ex9CBL-H, 10 kA

Dependence of Tripping Characteristics on Ambient Temperature

T [°C]	I _n (T) [A]							
	6 A	10 A	13 A	16 A	20 A	25 A	32 A	40 A
-20	8	13.5	17	20	24.5	29.8	39.5	50.5
-15	7.8	13.3	16.8	19.8	24.3	29.7	39.3	50.4
-10	7.6	13	16.5	19.5	24	29.5	39	50.2
-5	7.3	12.7	16.1	19.2	23.8	29.3	38.8	50
0	7.2	12.5	15.8	19.1	23.7	29.2	38.6	48.8
5	7	12.3	15.5	18.8	23.5	29	38.4	48.6
10	6.8	12.1	15.2	18.6	23.3	28.8	38.2	48.4
15	6.6	12	14.9	18.5	23.1	28.6	38	48.1
20	6.4	11.8	14.7	18.3	22.8	28.4	37.8	47.8
25	6.2	11.5	14.1	18	22.6	28.2	37.5	47
30	6	10	13	16	20	25	32	40
35	6	9.9	12.8	15.7	19.7	24.6	31.5	39.2
40	5.9	9.8	12.5	15.4	19.3	24.3	31.1	38.8
45	5.83	9.8	12.2	15.1	18.8	24	30.8	38.3
50	5.72	9.6	11.7	14.9	18.5	23.8	30.1	38
55	5.65	9.5	11.5	14.7	18.2	23.5	29.5	36.5
60	5.5	9	11.2	14.5	17.8	23	28.5	35
65	5.4	8.6	11	14	17.5	22	27.5	34
70	5.2	8	10.8	13.8	17.3	21.5	27	32.5

Technical Data Ex9CBL-N

Residual Current Breakers with Overload protection Ex9CBL-N, 6 kA

General parameters

Combination of MCB and RCCB in one case - saves 50 % space in comparison to combination of stand-alone MCB and RCCB
Tripping characteristics of installed circuit breaker B and C
AC and A type of residual current device
1+N-pole version
Suitable for household as well as industrial applications
Permanent magnet principle of residual current device - Voltage independent tripping function
Magnetic RCBOs should be tested regularly with a period of one month. This is a responsibility of the user of an installation given by law
Signaling of contacts status

Electrical parameters

Tested according to	IEC/EN 61009
Rated op. voltage U_e	230 V AC
Min. voltage for RCD function	voltage independent
Voltage range of the test button T	110 — 254 V AC
Rated frequency	50/60 Hz
Rated breaking capacity I_{cn}	6 kA
Rated current	6 — 40 A
Rated residual current	30, 100, 300 mA
Sensitivity to residual current	AC type - AC residual current A type - residual AC and pulsating DC current
Time characteristic of RCD	undelayed type
Tripping characteristics of MCB	B, C
Rated impulse withstand voltage U_{imp}	4 kV
Rated insulation voltage U_i	500 V
Mechanical service life	20 000 operation cycles
Electrical service life	4 000 operation cycles
Selectivity class	3
Back-up fuse/breaker	max. 125 A gG
Line voltage connection	arbitrary above or below

Mechanical parameters

Device width	36 mm
Device height	85 mm including rail clip
Frame size	45 mm
Mounting	easy fastening onto 35 mm device rail (DIN)
Degree of protection	IP20
Terminals	combined lift + open mouthed
Terminal capacity	1 — 35 mm ²
Fastening torque of terminals	1.5 — 2.5 Nm
Busbar thickness	0.8 — 2 mm
Ambient temperature	-25 — +40 °C
Altitude	≤ 2000 m
Relative humidity	≤ 95 %
Resistance to humidity and heat	class 2
Pollution degree	2
Installation class	III
Weight	0.2 kg

Technical Data Ex9CBL-N

Residual Current Breakers with Overload protection Ex9CBL-N, 6 kA

Dimensions

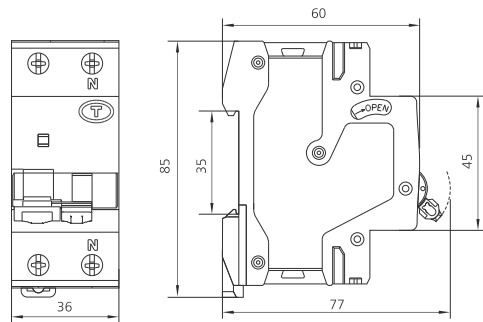

Wiring diagram

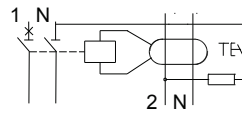

1P+N

Tripping characteristics of MCB

Characteristic B

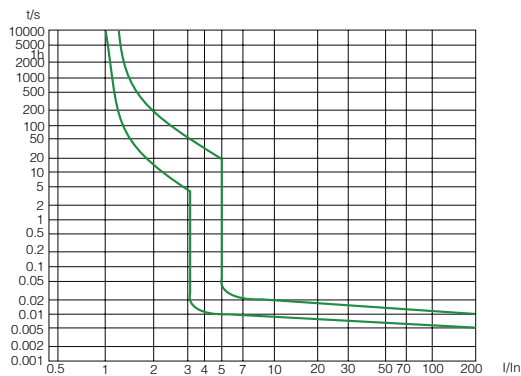

Characteristic C

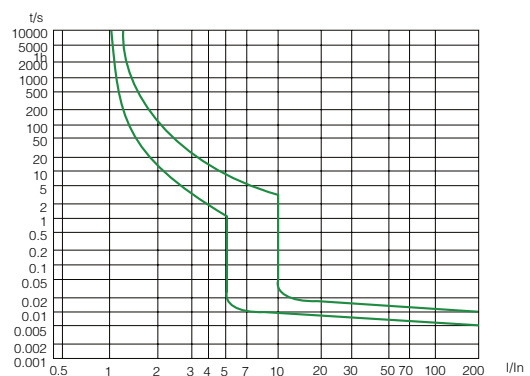

Tripping characteristics of RCD

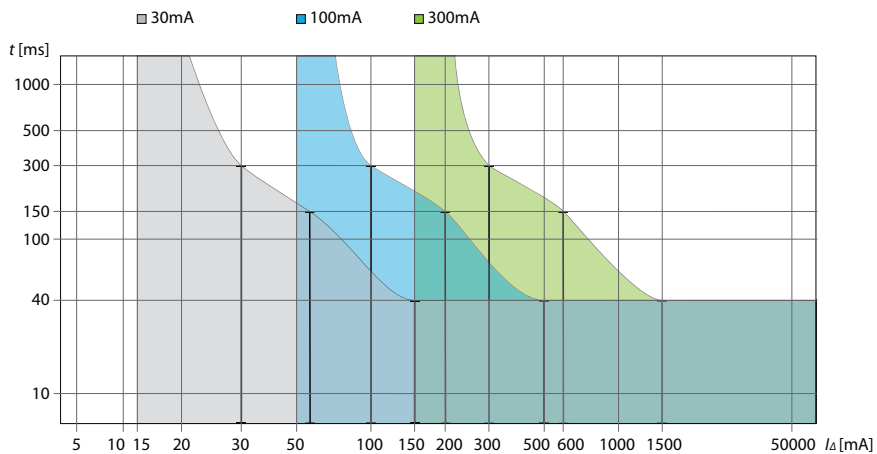

Technical Data Ex9CBL-N

Residual Current Breakers with Overload protection Ex9CBL-N, 6 kA

Dependence of Tripping Characteristics on Ambient Temperature

T [°C]	I _n (T) [A]							
	6 A	10 A	13 A	16 A	20 A	25 A	32 A	40 A
-20	8	13.5	17	20	24.5	29.8	39.5	50.5
-15	7.8	13.3	16.8	19.8	24.3	29.7	39.3	50.4
-10	7.6	13	16.5	19.5	24	29.5	39	50.2
-5	7.3	12.7	16.1	19.2	23.8	29.3	38.8	50
0	7.2	12.5	15.8	19.1	23.7	29.2	38.6	48.8
5	7	12.3	15.5	18.8	23.5	29	38.4	48.6
10	6.8	12.1	15.2	18.6	23.3	28.8	38.2	48.4
15	6.6	12	14.9	18.5	23.1	28.6	38	48.1
20	6.4	11.8	14.7	18.3	22.8	28.4	37.8	47.8
25	6.2	11.5	14.1	18	22.6	28.2	37.5	47
30	6	10	13	16	20	25	32	40
35	6	9.9	12.8	15.7	19.7	24.6	31.5	39.2
40	5.9	9.8	12.5	15.4	19.3	24.3	31.1	38.8
45	5.83	9.8	12.2	15.1	18.8	24	30.8	38.3
50	5.72	9.6	11.7	14.9	18.5	23.8	30.1	38
55	5.65	9.5	11.5	14.7	18.2	23.5	29.5	36.5
60	5.5	9	11.2	14.5	17.8	23	28.5	35
65	5.4	8.6	11	14	17.5	22	27.5	34
70	5.2	8	10.8	13.8	17.3	21.5	27	32.5

Technical Data Ex9LE

RCD add-on blocks Ex9LE

General parameters

RCD add-on blocks for combination with miniature circuit breakers Ex9B
Allow to create various combinations with MCBs with functionality of RCBO
AC type of residual current device
1+N, 2, 3, 3+N and 4-pole versions
Input voltage is connected via MCB
Electronic technology of residual current device - more accurate measuring of residual current, not necessary to test monthly. For possible use of this device, local legal requirements and conditions must be fulfilled.
Recommended testing period one year to fulfill requirements of product standards. Contrary to permanent magnet-based devices, the testing is not necessary to preserve proper sensitivity of the RCD
Given pole version of the RCD add-on block must be combined with MCB Ex9B in the following way. 1+N-pole version of RCD add-on block is possible to combine with 1-pole MCB; 2-pole RCD block with 1+N or 2-pole MCB; 3-pole and 3+N-pole RCD block with 3-pole MCB, 4-pole RCD block with 3+N or 4-pole MCB

Electrical parameters

Tested according to	IEC/EN 61009-1
Rated op. voltage U_e	230/400 V AC
Min. voltage for RCD function	50 V AC
Voltage range of the test button T	150 — 440 V AC
Rated frequency	50/60 Hz
Conditional short circuit strength I_{nc}	10 kA with Ex9BH, 6 kA with Ex9BN
Rated current (max. rated current of connected MCB)	40, 63 A
Rated residual current	10, 30, 100, 300 mA
Sensitivity to residual current	AC type - AC residual current
Time characteristic of RCD	undelayed type
Rated impulse withstand voltage U_{imp}	4 kV
Rated insulation voltage U_i	500 V
Surge current-proof	250 A
Mechanical service life	16 000 operation cycles
Electrical service life	8 000 operation cycles
Back-up fuse/breaker	co-installed MCB
Line voltage connection	above to MCB

Mechanical parameters

Device width (without MCB busbar)	54 mm (1+N-pole), 72 mm (2-pole), 117 mm (3-pole), 117 mm (3+N-pole), 135 mm (4-pole)
Device height	89 mm including rail clip and connection busbar
Frame size	45 mm
Mounting	easy fastening onto 35 mm device rail (DIN)
Degree of protection	IP20
Terminals	combined lift + open mouthed
Terminal capacity	1 — 35 mm ²
Fastening torque of terminals	2 — 3.5 Nm
Busbar thickness	0.8 — 2 mm
Ambient temperature	-25 — +40 °C
Altitude	≤ 2000 m
Relative humidity	≤ 95 %
Resistance to humidity and heat	class 2
Pollution degree	2
Installation class	III

Technical Data Ex9LE

RCD add-on blocks Ex9LE

Dimensions

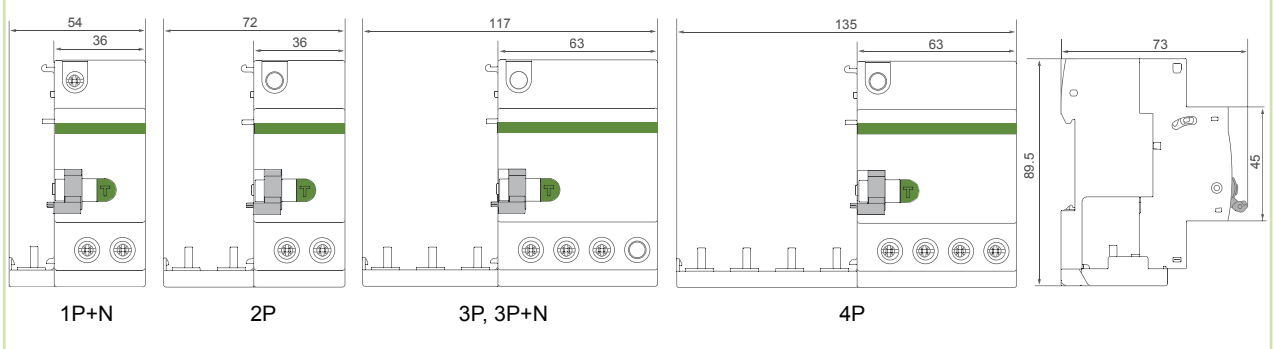

Wiring diagrams

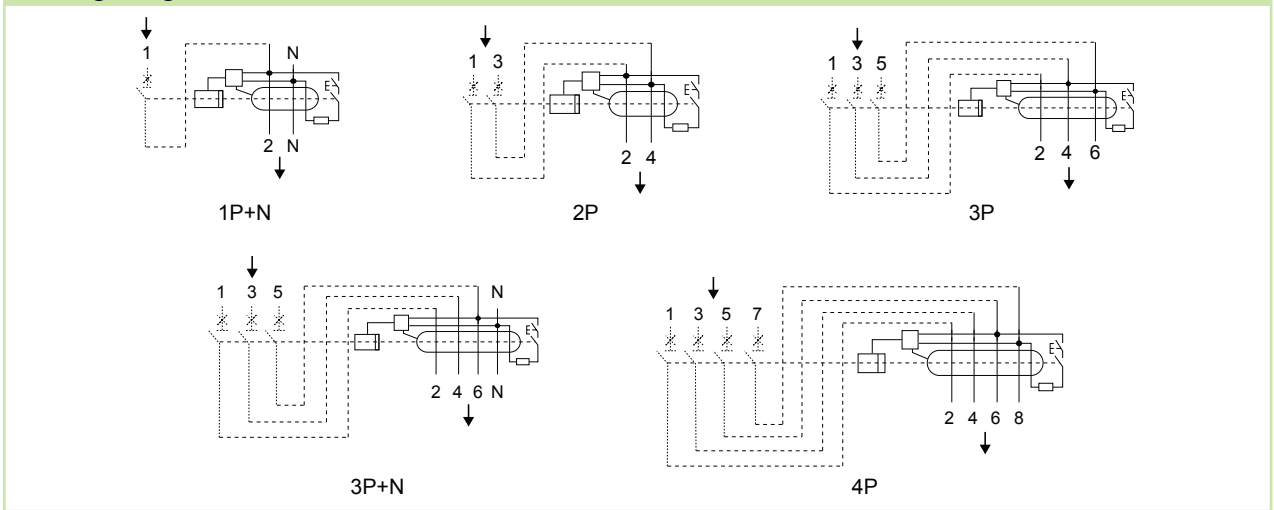

Tripping characteristics of RCD

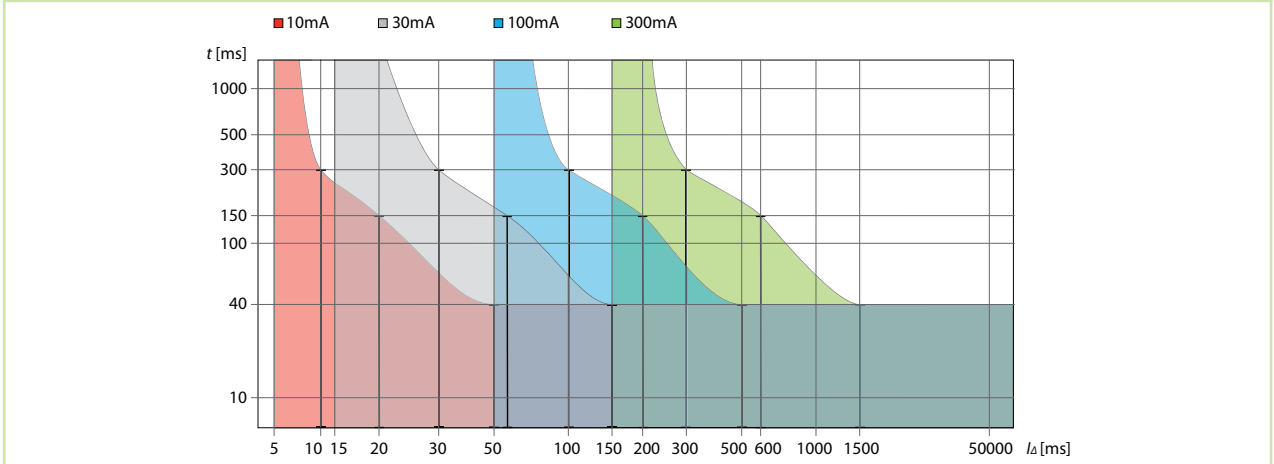

Technical Data Accessories

Accessories for Ex9B and Ex9PN devices

Auxiliary and signal contact units AX31, AL31, AXL31

General parameters

With one circuit breaker Ex9B., it can be used up to three contact units with single CO contact or up to two contact units with 2 CO
Contact units can be combined in an arbitrary way
Contact units are mounted to the circuit breaker from the left
In case of installed release unit(s), contact modules are mounted left to the release(s)
Auxiliary contacts synchronous with main contacts of the circuit breaker
Signal contacts active on electrical tripping of the circuit breaker (tripping signal contacts)

Electrical parameters

	AX3111	AX3122	AL3111	AXL31
Contacts	1 changeover (CO)	2 changeover (CO)	1 changeover (CO)	1 CO + 1 CO
Contact function	auxiliary	auxiliary	signal	auxiliary + signal
Tested according to	IEC/EN 60947-1, IEC/EN 60947-5-1			
Rated op. voltage	240/415 V AC, 24/48/130 V DC			
Min. op. voltage per contact U_{min}	24 V AC/DC			
Rated frequency	50/60 Hz			
Rated op. current I_e AC	6 A (240 V), 3 A (415 V)			
Rated op. current I_e DC	6 A (24 V), 2 A (48 V), 1 A (130 V)			
Rated thermal current I_{th}	6 A			
Rated op. current I_e , ut. cat. AC-12	6 A (240 V), 3 A (415 V)			
Rated op. current I_e , ut. cat. DC-12	6 A (24 V), 2 A (48 V), 1 A (130 V)			
Rated impulse withstand voltage U_{imp}	4 kV (1.2/50 μ s)			
Rated insulation voltage U_i	500 V			
Max. back-up fuse	10 A gG			
Conditional short circuit current I_k with max. back-up fuse	1 kA			

Mechanical parameters

	AX3111	AX3122	AL3111	AXL31
Tripping indicator	ON-OFF-RESET	ON-OFF-RESET	ON-OFF-RESET	ON-OFF-RESET
Device width	9 mm			
Device height	89 mm			
Frame size	45 mm			
Mounting	easy fastening onto 35 mm device rail (DIN)			
Degree of protection	IP20			
Terminals	lift			
Terminal capacity	1 — 6 mm ²			
Fastening torque of terminals	0.8 — 1 Nm			

Technical Data Accessories

Accessories for Ex9B and Ex9PN devices

Auxiliary and signal contact units AX31, AL31, AXL31

Dimensions

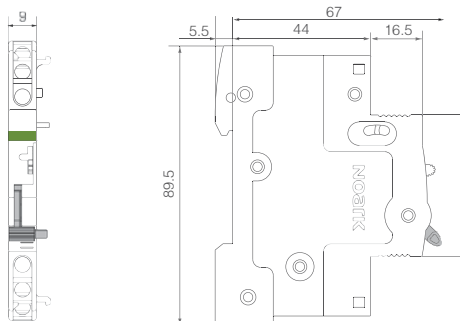

Wiring diagrams

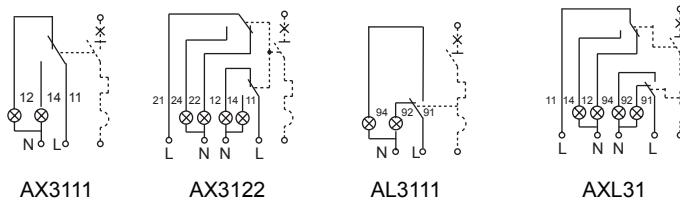

Technical Data Accessories

Accessories for Ex9B and Ex9PN devices

Shunt trip releases SHT31

General parameters

With one circuit breaker Ex9B., it can be used up to two units of release (shunt trip, undervoltage, overvoltage)

Release units can be combined in an arbitrary way

Release units are mounted to the circuit breaker from the left

In case of installed contact module(s), release units are mounted left to the breaker, right to the contact unit(s)

Can be used for remote switch off

Electrical parameters

	SHT31 110V-415V AC/110V-130V DC SHT3111 110V-415V AC/110V-130V DC	SHT31 48V AC/DC SHT3111 48V AC/DC	SHT31 12-24V AC/DC SHT3111 12-24V AC/DC
Contacts	- 1 changeover (CO)	- 1 changeover (CO)	- 1 changeover (CO)
Contact function	auxiliary	auxiliary	auxiliary
Tested according to	IEC/EN 60947-1, IEC/EN 60947-5-1		
Rated operating voltage	110-415 V AC, 110-130 V DC	48 V AC/DC	12-24 V AC/DC
Rated frequency	50/60 Hz		
Rated impulse withstand voltage U_{imp}	4 kV (1.2/50 μ s)		
Rated insulation voltage	500 V		
Tripping time	< 10 ms	< 10 ms	< 10 ms
Min. duration of control pulse	8 ms	8 ms	8 ms
Max. back-up fuse	10 A gG	10 A gG	10 A gG
Min. op. voltage per AX contact U_{min}	24 V AC/DC		
Rated op. current I_e AC of AX contact	6 A (240 V), 3 A (415 V)		
Rated op. current I_e DC of AX contact	6 A (24 V), 2 A (48 V), 1 A (130 V)		
Rated thermal current I_{th} of AX cont.	6 A		
Rated op. current I_e , AC-12 of AX	6 A (240 V), 3 A (415 V)		
Rated op. current I_e , DC-12 of AX	6 A (24 V), 2 A (48 V), 1 A (130 V)		
Max. back-up fuse of AX	10 A gG		
Conditional short circuit current I_k with max. back-up fuse of AX	1 kA		

Mechanical parameters

	SHT31 110V-415V AC/110V-130V DC SHT3111 110V-415V AC/110V-130V DC	SHT31 48V AC/DC SHT3111 48V AC/DC	SHT31 12-24V AC/DC SHT3111 12-24V AC/DC
Tripping indicator	red-white	red-white	red-white
Device width	18 mm		
Device height	83 mm		
Frame size	45 mm		
Mounting	easy fastening onto 35 mm device rail (DIN)		
Degree of protection	IP20		
Terminals	lift		
Terminal capacity	1 — 6 mm ²		
Fastening torque of terminals	0.8 — 1 Nm		

Technical Data Accessories

Accessories for Ex9B and Ex9PN devices

Shunt trip releases SHT31

Dimensions

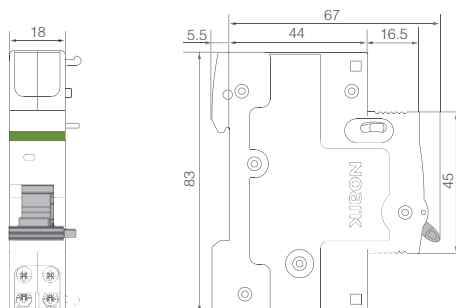

Wiring diagrams

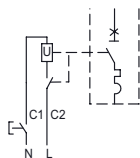

SHT31

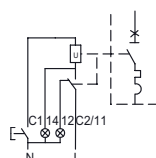

SHT3111

Technical Data Accessories

Accessories for Ex9B and Ex9PN devices

Undervoltage releases UVT31

General parameters

With one circuit breaker Ex9B., it can be used up to two units of release (shunt trip, undervoltage, overvoltage)

Release units can be combined in an arbitrary way

Release units are mounted to the circuit breaker from the left

In case of installed contact module(s), release units are mounted left to the breaker, right to the contact unit(s)

To switch connected breaker off in case of voltage drop

Electrical parameters

	UVT31 220-240V AC UVT3101 220-240V AC UVT3110 220-240V AC	UVT31 48V AC/DC UVT3101 48V AC/DC UVT3110 48V AC/DC
Contacts	- 1 normally closed (NC) 1 normally open (NO)	- 1 normally closed (NC) 1 normally open (NO)
Contact function	auxiliary	auxiliary
Tested according to	IEC/EN 60947-1, IEC/EN 60947-5-1	
Rated operating voltage U_n	220-240 V AC	48 V AC/DC
Rated frequency	50/60 Hz	
Rated impulse withstand voltage U_{imp}	4 kV (1.2/50 μ s)	
Rated insulation voltage	500 V	
Tripping time	< 10 ms	< 10 ms
Making treshold	85 % U_n	85 % U_n
Tripping treshold	35 % U_n	35 % U_n
Min. op. voltage per AX contact U_{min}	24 V AC/DC	
Rated op. current I_e AC of AX contact	6 A (240 V), 3 A (415 V)	
Rated op. current I_e DC of AX contact	6 A (24 V), 2 A (48 V), 1 A (130 V)	
Rated thermal current I_{th} of AX cont.	6 A	
Rated op. current I_e , AC-12 of AX	6 A (240 V), 3 A (415 V)	
Rated op. current I_e , DC-12 of AX	6 A (24 V), 2 A (48 V), 1 A (130 V)	
Max. back-up fuse of AX	10 A gG/gL	
Conditional short circuit current I_k with max. back-up fuse of AX	1 kA	

Mechanical parameters

	UVT31 220-240V AC UVT3101 220-240V AC UVT3110 220-240V AC	UVT31 48V AC/DC UVT3101 48V AC/DC UVT3110 48V AC/DC
Tripping indicator	red-white	red-white
Device width	18 mm	
Device height	83 mm	
Frame size	45 mm	
Mounting	easy fastening onto 35 mm device rail (DIN)	
Degree of protection	IP20	
Terminals	lift	
Terminal capacity	1 — 6 mm ²	
Fastening torque of terminals	0.8 — 1 Nm	

Technical Data Accessories

Accessories for Ex9B and Ex9PN devices

Undervoltage releases UVT31

Dimensions

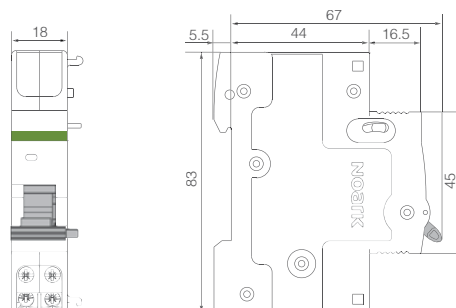

Wiring diagrams

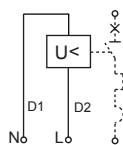

UVT31

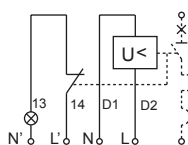

UVT3101

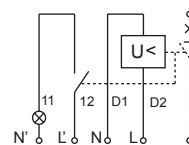

UVT3110

Technical Data Accessories

Accessories for Ex9B and Ex9PN devices

Overvoltage releases OVT31

General parameters

With one circuit breaker Ex9B., it can be used up to two units of release (shunt trip, undervoltage, overvoltage)
Release units can be combined in an arbitrary way
Release units are mounted to the circuit breaker from the left
In case of installed contact module(s), release units are mounted left to the breaker, right to the contact unit(s)
Overvoltage release is not a protection against transient overvoltage and does not supersede surge protection devices
To switch connected breaker off in case of increased voltage

Electrical parameters

Contacts	-
Tested according to	IEC/EN 60947-1, IEC/EN 60947-5-1
Rated operating voltage U_n	280 V AC $\pm 5\%$
Rated frequency	50/60 Hz
Rated impulse withstand voltage U_{imp}	4 kV (1.2/50 μ s)
Rated insulation voltage	500 V
Tripping time	< 1 s (290 V), < 0,1 s (380 V)

Mechanical parameters

	OVT31 280V AC$\pm 5\%$
Tripping indicator	red-white
Device width	18 mm
Device height	83 mm
Frame size	45 mm
Mounting	easy fastening onto 35 mm device rail (DIN)
Degree of protection	IP20
Terminals	lift
Terminal capacity	1 — 6 mm ²
Fastening torque of terminals	0.8 — 1 Nm

Technical Data Accessories

Accessories for Ex9B and Ex9PN devices

Overvoltage releases OVT31

Dimensions

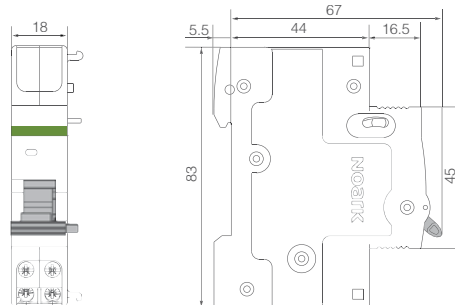

Wiring diagram

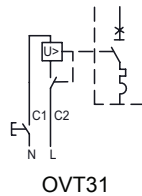

Technical Data Accessories

Accessories for RCBOs line Ex9CBL

Shunt trip releases SHTC31

General parameters

With one RCBO can be used up to two release units (shunt trip or undervoltage), they can be combined in an arbitrary way

Releases are mounted to the device from the left side

SHTC31 can be used for remote switch off function

Electrical parameters

	SHTC31 230/400V AC	SHTC31 24V AC	SHTC31 48V DC	SHTC31 24V DC
Build-in AX contacts	1 changeover (CO)	1 changeover (CO)	1 changeover (CO)	1 changeover (CO)
Contact function	auxiliary	auxiliary	auxiliary	auxiliary
Tested according to	IEC/EN 60947-5			
Rated operating voltage U_n	230/400 V AC	24 V AC	48 V DC	24 V DC
Operating voltage range	70 - 110% U_n			
Rated frequency	50/60 Hz		-	
Rated impulse withstand voltage U_{imp}	4 kV (1.2/50 μ s)			
Rated insulation voltage	500 V			
Tripping time	< 10 ms			
Min. duration of control pulse	8 ms			
Max. back-up fuse	10 A gG			
Electrical service life	4 000 operating cycles			
Min. op. voltage per AX contact U_{min}	24 V AC/DC			
Rated op. current I_e AC of AX contact	6 A (240 V), 3 A (415 V)			
Rated op. current I_e DC of AX contact	6 A (24 V), 2 A (48 V)			
Rated thermal current I_{th} of AX cont.	6 A			
Rated op. current I_e , AC-12 of AX	6 A (240 V), 3 A (415 V)			
Rated op. current I_e , DC-12 of AX	6 A (24 V), 2 A (48 V)			
Max. back-up fuse of AX	10 A gG			
Conditional short circuit current I_k with max. back-up fuse of AX	1 kA			

Mechanical parameters

	SHTC31 230/400V AC	SHTC31 24V AC	SHTC31 48V DC	SHTC31 24V DC
Tripping indicator	red-white	red-white	red-white	red-white
Device width	18 mm			
Device height	83 mm			
Frame size	45 mm			
Mounting	easy fastening onto 35 mm device rail (DIN)			
Degree of protection	IP20			
Mechanical service life	4 000 operating cycles			
Terminals	lift			
Terminal capacity	2.5 mm ²			
Fastening torque of terminals	0.8 Nm			
Ambient temperature	-5 — +40 °C			
Storage temperature	-25 — +70 °C			
Pollution degree	2			

Technical Data Accessories

Accessories for RCBOs line Ex9CBL

Shunt trip releases SHTC31

Dimensions

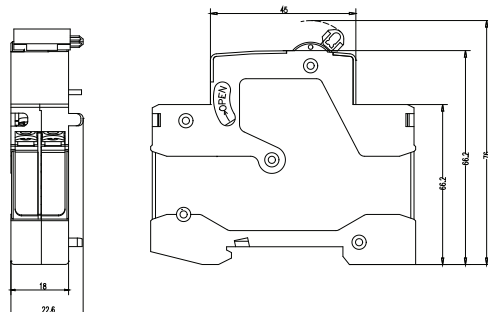

Wiring diagram

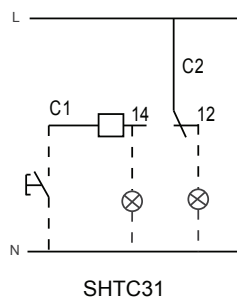

Technical Data Accessories

Accessories for RCBOs line Ex9CBL

Undervoltage release UVTC31

General parameters

With one RCBO can be used up to two release units (shunt trip or undervoltage), they can be combined in an arbitrary way

Release units are mounted to the RCBO from the left side

To switch connected device off in case of voltage drop

Electrical parameters

	UVTC31 230V AC
Build-in AX contacts	-
Tested according to	IEC/EN 60947-5
Rated operating voltage U_n	230 V AC
Rated frequency	50/60 Hz
Rated impulse withstand voltage U_{imp}	4 kV (1.2/50 μ s)
Rated insulation voltage	500 V
Tripping time	< 10 ms
Making threshold	85 % U_n
Tripping threshold	35 % U_n
Electrical service life	4 000 operating cycles

Mechanical parameters

	UVTC31 230V AC
Tripping indicator	red-white
Device width	18 mm
Device height	83 mm
Frame size	45 mm
Mounting	easy fastening onto 35 mm device rail (DIN)
Degree of protection	IP20
Mechanical service life	4 000 operating cycles
Terminals	lift
Terminal capacity	2.5 mm ²
Fastening torque of terminals	0.8 Nm
Ambient temperature	-5 — +40 °C
Storage temperature	-25 — +70 °C
Pollution degree	2

Technical Data Accessories

Accessories for RCBOs line Ex9CBL

Undervoltage release UVTC31

Dimensions

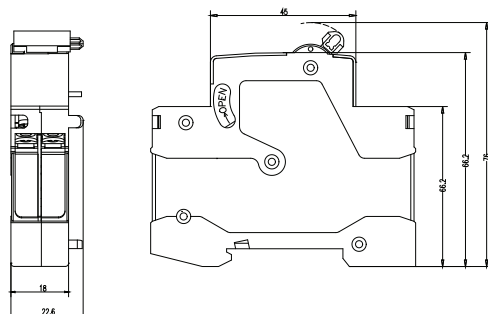

Wiring diagram

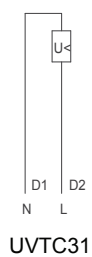

Technical Data Ex9UE1+2

Surge Protection Devices Type 1+2

General parameters

Suitable for protection of electrical installations against transient overvoltage and indirect lightning strikes

Plug-in module design

Indication window and optional remote-signaling contact helps users to know the status of device

Due to limp 12.5 kA per pole suitable for LPL III and LPL IV according to EN 62305 in standard 3-phase TN-C and TN-S installations

Electrical parameters

	1+0, 2+0, 3+0, 4+0	1+1, 3+1
Tested according to	EN 61643-11	
Classified type (test class)	Type 1+2 (Class I+II, B+C, T1+T2)	
Technology		
L-N	MOV (Varistor)	MOV (Varistor)
N-PE	MOV (Varistor)	GDT (Spark-gap)
Max. continuous operational voltage U_c		
L-N	275 V AC	275 V AC
N-PE	275 V AC	255 V AC
Nominal frequency f	50/60 Hz	
Nominal discharge current I_n (8/20 μ s)		
L-N	25 kA per pole	25 kA per pole
N-PE	25 kA per pole	50 kA per pole
Max. impulse current I_{imp} (10/350 μ s)		
L-N	12.5 kA per pole	12.5 kA per pole
N-PE	12.5 kA per pole	50 kA per pole
Max discharge current I_{max} (8/20 μ s)	50 kA per pole	
Protection voltage U_p at I_n		
L-N	1.5 kV	1.5 kV
N-PE	1.5 kV	1.5 kV
Protection voltage U_p at I_{max}		
L-N	1.8 kV	1.8 kV
N-PE	1.8 kV	1.5 kV
Protection voltage U_p at 5 kA (8/20 μ s)		
L-N	1 kV	1 kV
N-PE	1 kV	-
N-PE follow current interrupting rating I_{fi}	-	100 A
Temporary overvoltage U_t (withstand)		
L-N, 5 s	335 V	335 V
N-PE, 200 ms	335 V	1200 V
MOV voltage of 1mA point	387 - 473 V	
Max. back-up fuse		
L-N	max. 160 A gG	max. 160 A gG
N-PE	max. 160 A gG	-
Short-circuit withstand capability		
L-N	50 kA	50 kA
N-PE	50 kA	-
Specific energy W/R	156.25 kJ/ Ω	
Remote contact (optional)	1 changeover (CO)	
Remote contact op. voltage / current		
AC U_{max} / I_{max}	250 V AC / 1 A	
DC U_{max} / I_{max}	30 V DC / 1 A	

Technical Data Ex9UE2

Surge Protection Devices Type 2

General parameters

Suitable for protection of electrical installations against transient overvoltage
Plug-in module design
Indication window helps users to know the status of device
Optional remote-signaling contact

Electrical parameters

	1+0, 2+0, 3+0, 4+0				1+1, 3+1			
Tested according to	EN 61643-11							
Classified type (test class)	Type 2 (Class II, C, T2)							
Technology								
L-N	MOV (Varistor)				MOV (Varistor)			
N-PE	MOV (Varistor)				GDT (Spark-gap)			
Max. continuous operational voltage U_c								
L-N	275 V AC	320 V AC	385 V AC	440 V AC	275 V AC	320 V AC	385 V AC	440 V AC
N-PE	275 V AC	320 V AC	385 V AC	440 V AC	255 V AC			
Nominal frequency f	50/60 Hz							
Nominal discharge current I_n (8/20 μ s)								
L-N	20 kA per pole				20 kA per pole			
N-PE	20 kA per pole				40 kA per pole			
Max. impulse current I_{imp} (10/350 μ s)								
L-N	-				-			
N-PE	-				12 kA per pole			
Max discharge current I_{max} (8/20 μ s)	40 kA per pole							
Protection voltage U_p at I_n								
L-N	1.4 kV	1.6 kV	1.9 kV	2.2 kV	1.4 kV	1.6 kV	1.9 kV	2.2 kV
N-PE	1.4 kV	1.6 kV	1.9 kV	2.2 kV	1.5 kV			
Protection voltage U_p at I_{max}								
L-N	2 kV	2.3 kV	2.5 kV	2.8 kV	2 kV	2.3 kV	2.5 kV	2.8 kV
N-PE	2 kV	2.3 kV	2.5 kV	2.8 kV	1.5 kV			
Protection voltage U_p at 5 kA (8/20 μ s)								
L-N	1 kV	1.15 kV	1.3 kV	1.5 kV	1 kV	1.15 kV	1.3 kV	1.5 kV
N-PE	1 kV	1.15 kV	1.3 kV	1.5 kV	-			
N-PE follow current interrupting rating I_{fi}	-				100 A			
Temporary overvoltage U_t (withstand)								
L-N, 5 s	335 V	405 V	490 V	580 V	335 V	405 V	490 V	580 V
N-PE, 200 ms	335 V	405 V	490 V	580 V	1200 V			
MOV voltage of 1mA point	387-473 V	460-561 V	554-677 V	639-781 V	387-473 V	460-561 V	554-677 V	639-781 V
Max. back-up fuse								
L-N	max. 125 A gG				max. 125 A gG			
N-PE	max. 125 A gG				-			
Short-circuit withstand capability								
L-N	50 kA				50 kA			
N-PE	50 kA				-			
Remote contact (optional)	1 changeover (CO)							
Remote contact op. voltage / current								
AC U_{max} / I_{max}	250 V AC / 1 A							
DC U_{max} / I_{max}	30 V DC / 1 A							

Technical Data Ex9UE

Surge Protection Devices Type 1+2 and Type 2

Mechanical parameters

Device width	17.5 mm (per pole/module)
Device height	83 mm (89 mm including rail clip)
Frame size	45 mm
Mounting	easy fastening onto 35 mm device rail (DIN)
Degree of protection	IP40, terminals IP20
Terminals	M5 screws
Terminal capacity	2.5 — 35 mm ²
Fastening torque of terminals	2 — 3.5 Nm
Remote contact terminal capacity	0.14 — 1.5 mm ²
Ambient temperature	-40 — +80 °C
Altitude	≤ 2000 m
Relative humidity	30 — 90 %
Weight (per pole) T1+2 / T2	0.15 / 0.11 kg

Dimensions

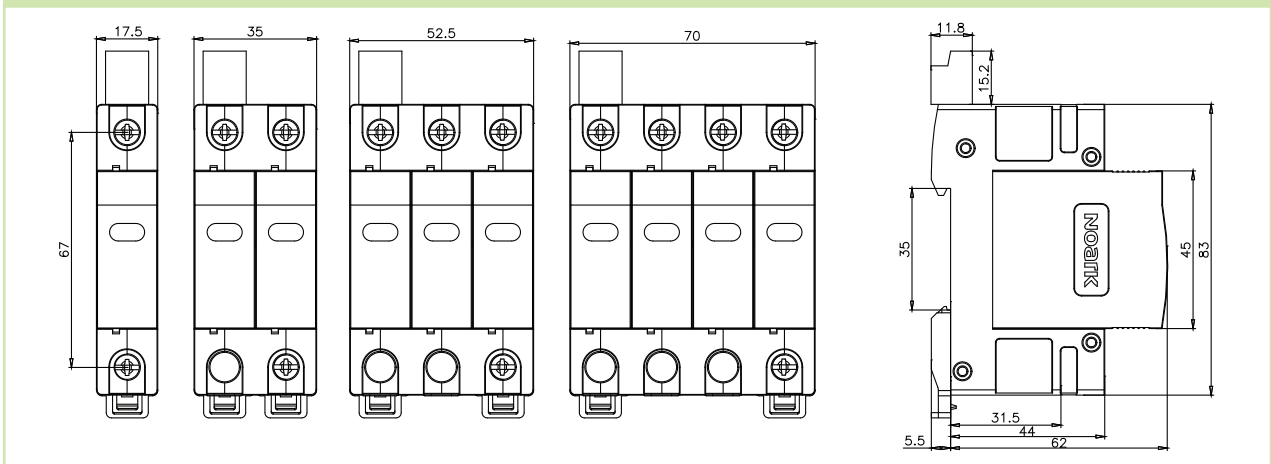

Wiring diagrams

3+0 TN-C

Connection type 3+0 in TN-C system consists of three identical SPDs.

Fu₁-Fu₃ represent main protection (fuses, circuit breaker) in the installation.
 In case when Fu₁,Fu₂,Fu₃ > Max. back-up fuse for given SPDs, Fu'₁,Fu'₂,Fu'₃ have to be used. Fu'₁,Fu'₂,Fu'₃ ≤ Max. back-up fuse of the SPDs.

Surge Protection Devices Type 1+2 and Type 2

Wiring diagrams

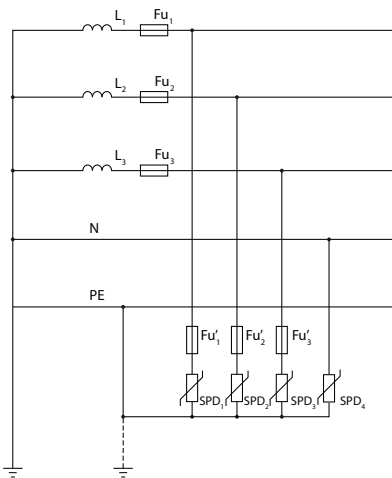

4+0 TN-S

Connection type 4+0 in TN-S system consists of four identical SPDs. This type of connection is suitable mainly to suppress longitudinal type of transient overvoltage, typically caused by atmospheric stroke. The advantages lay in uniform conducting of lightning current from phase and N-conductors. It also effectively protects insulation of conductors suffered with consecutive effects of a lightning stroke. This connection does not provide optimum protection in case transversal overvoltage (typically caused by wanted and unwanted fast switching processes) and thus it is not the best solution for protection of equipment and end consumers. It follows from the fact that residual transversal overvoltage between L and N conductors is given by protection level of two SPDs connected in a series. (e.g. Up of $SPD_1 + SPD_4$ for $L_1 - N$)

$Fu_1 - Fu_3$ represent main protection (fuses, circuit breaker) in the installation. In case when $Fu_1, Fu_2, Fu_3 > \text{Max. back-up fuse for given SPDs}$, Fu'_1, Fu'_2, Fu'_3 have to be used. $Fu'_1, Fu'_2, Fu'_3 \leq \text{Max. back-up fuse of the SPDs}$.

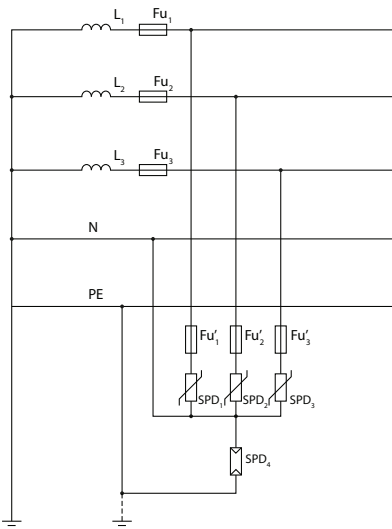

3+1 TN-S

Connection type 3+1 in TN-S system consists of three identical SPDs and one sum spark gap. It is suitable mainly to suppress transversal type of transient overvoltage, typically caused by wanted and unwanted fast switching processes. Main advantage is minimization of residual transversal overvoltage between L and N, which is defined dominantly by protection level of a single SPD. This diagram is recommended for protection of end consumers in TN-S system. A disadvantage for suppression of atmospheric longitudinal overvoltage follows from non-uniform protection of L and N conductors. When used for protection against longitudinal effects, usually as a protection against lightning stroke current (SPD class I), I_{imp} of sum spark gap SPD_4 must be min. $4 \times I_{imp}$ of SPD_1, SPD_2, SPD_3 .

$Fu_1 - Fu_3$ represent main protection (fuses, circuit breaker) in the installation. In case when $Fu_1, Fu_2, Fu_3 > \text{Max. back-up fuse for given SPDs}$, Fu'_1, Fu'_2, Fu'_3 have to be used. $Fu'_1, Fu'_2, Fu'_3 \leq \text{Max. back-up fuse of the SPDs}$.

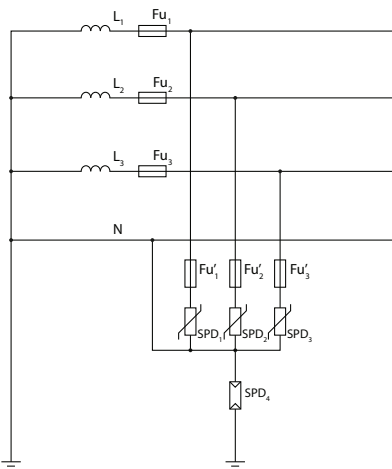

3+1 TT

In order to keep insulation status between N conductor and ground potential, connection 3+1 is recommended for TT systems. It provides maximum protection against transversal transient overvoltage and significantly limits longitudinal one.

$Fu_1 - Fu_3$ represent main protection (fuses, circuit breaker) in the installation. In case when $Fu_1, Fu_2, Fu_3 > \text{Max. back-up fuse for given SPDs}$, Fu'_1, Fu'_2, Fu'_3 have to be used. $Fu'_1, Fu'_2, Fu'_3 \leq \text{Max. back-up fuse of the SPDs}$.

Surge Protection Devices Type 1+2 and Type 2

Wiring diagrams

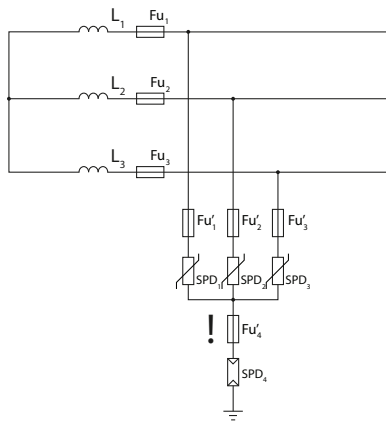

3+1 IT

3+1 connection in IT system is suitable for protection against both transversal as well as longitudinal overvoltage. Due to grounded sum spark gap allows effective reduction of effects caused by lightning currents. Particular SPDs are dimensioned to "phase" voltage of the system (i.e. to 230 V in 230/400V grid). An important difference to 3+1 connection in TN-S system is back up fuse for sum spark gap. This protection has to be used in IT systems. It ensures insulation status in case of spark gap malfunction like uninterrupted follow currents.

Fu_1 - Fu_3 represent main protection (fuses, circuit breaker) in the installation. In case when $Fu_1, Fu_2, Fu_3 > Max.$ back-up fuse for given SPDs, Fu'_1, Fu'_2, Fu'_3 have to be used. $Fu'_1, Fu'_2, Fu'_3 \leq Max.$ back-up fuse of the SPDs. $Fu'_4 \leq Max.$ back up fuse of the sum spark gap SPD₄.

Note: Connection diagram is indicative only. There have to be observed and fulfill potential other requirements, e.g. insulation tests of sum spark gap etc., in actual IT system.

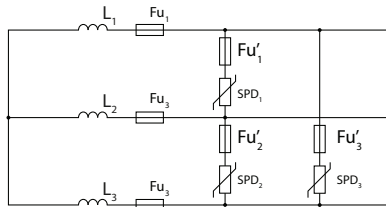

3+0 IT

This type of connection is suitable for protection against transversal overvoltage caused by switching processes. Particular SPDs must be dimensioned for phase-phase voltage.

Fu_1 - Fu_3 represent main protection (fuses, circuit breaker) in the installation. In case when $Fu_1, Fu_2, Fu_3 > Max.$ back-up fuse for given SPDs (transformed to single phase voltage), Fu'_1, Fu'_2, Fu'_3 have to be used. $Fu'_1, Fu'_2, Fu'_3 \leq Max.$ back-up fuse of the SPDs.

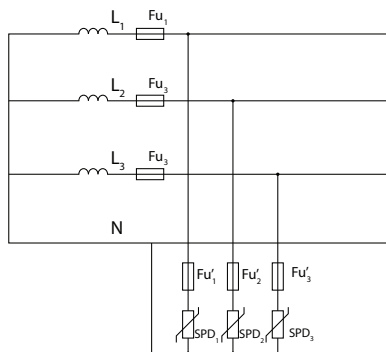

3+0 local isolated system with N conductor (hospitals, chemical industry, etc.)

This type of connection is suitable for protection against transversal overvoltage caused by switching processes. Because such system is designed in order to maximize availability of main voltage, there must be assumed first fault in the system as a standard operational regime. Due to this reason, particular SPDs must be dimensioned for phase-phase voltage (i.e. to 400 V in 230/400 V system).

Fu_1 - Fu_3 represent main protection (fuses, circuit breaker) in the installation. In case when $Fu_1, Fu_2, Fu_3 > Max.$ back-up fuse for given SPDs, Fu'_1, Fu'_2, Fu'_3 have to be used. $Fu'_1, Fu'_2, Fu'_3 \leq Max.$ back-up fuse of the SPDs.

Surge Protection Devices Type 1+2 and Type 2

Wiring diagrams

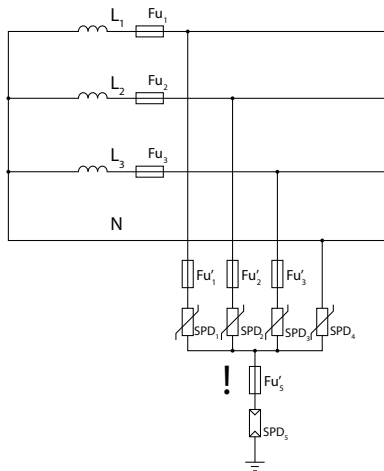

4+1 local isolated with N conductor (hospitals, chemical industry, etc.)

This connection is suitable for limitation of both transversal as well as longitudinal surges. Thanks to SPD₄, it provides much fine and balanced protection of all phase conductors in comparison to connection 3+1. It also more effectively limits phase – phase transversal overvoltage. Particular devices SPD₁-SPD₄ are dimensioned for phase voltage (i.e. to 230 V in 230/400 V system). As in standards IT system, sum spark gap SPD₅ has to be protected with back up fuse to ensure insulation of the system. **Local requirements on the sum spark gap have to be followed in particular applications.**

Fu₁-Fu₃ represent main protection (fuses, circuit breaker) in the installation. In case when $Fu_1, Fu_2, Fu_3 > \text{Max. back-up fuse for given SPDs}$, Fu'₁, Fu'₂, Fu'₃ have to be used. $Fu'_1, Fu'_2, Fu'_3 \leq \text{Max. back-up fuse of the SPDs}$. $Fu'_5 \leq \text{Max. back up fuse of the sum spark gap SPD}_5$.

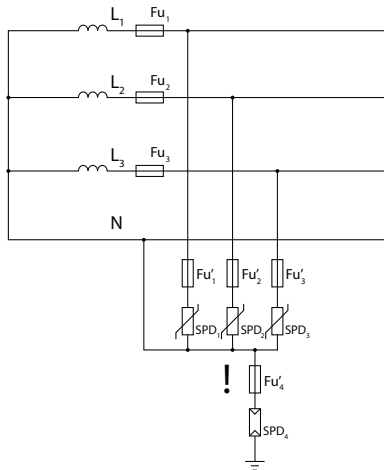

3+1 local isolated with N conductor (hospitals, chemical industry, etc.)

Situation is similar to 4+1 connection. Particular devices SPD₁-SPD₃ are dimensioned for phase - phase voltage (i.e. to 400 V in 230/400 V system) not to be overloaded in case of the first, generally non-tripped, fault. This connection is suitable for consumers for which transient overvoltage between phase and N conductors matters most. Sum spark gap SPD₄ has to be protected with back up fuse. **Local requirements on the sum spark gap have to be followed in particular applications.**

Fu₁-Fu₃ represent main protection (fuses, circuit breaker) in the installation. In case when $Fu_1, Fu_2, Fu_3 > \text{Max. back-up fuse for given SPDs}$, Fu'₁, Fu'₂, Fu'₃ have to be used. $Fu'_1, Fu'_2, Fu'_3 \leq \text{Max. back-up fuse of the SPDs}$. $Fu'_4 \leq \text{Max. back up fuse of the sum spark gap SPD}_4$.

Technical Data Ex9CH20

Installation relays

General parameters

2 and 4-contact versions, various contact combinations
Indication window help users to know the status of device
Low operating noise level

Electrical parameters

Tested according to	IEC / EN 61095
Rated operational voltage U_e	230/400 V AC
Control voltage U_c	24 V AC / 230 V AC / 240 V AC
Rated insulation voltage U_i	500 V
Rated impulse withstand voltage U_{imp}	4 kV
Rated conventional thermal current I_{th}	20 A
Rated current I_e AC-1, AC-7a	20 A
Rated current I_e AC-7b	9 A
Controlled power AC-7a	4 kW
Electrical service life	100 000 operating cycles
Max. switching frequency	300 per hour
Duty	100 %
Making and breaking conditions AC-7a	
I_c/I_e	1.0
U_r/U_e	1.05
$\cos \phi$	0.8
Coil power consumption (2P / 4P)	3.68 / 5.31 VA 1.47 / 1.56 W
Ambient temperature	-5 — +40 °C (+40 — +70 °C derated)
Rated thermal current in different ambient temperature (derating)	
40°C	20 A
50°C	18 A
60°C	16 A
70°C	14 A

Mechanical parameters

Device width	2-contact versions: 18 mm (1MU) 4-contact versions: 36 mm (2MU)
Device height	81 mm (84.5 including rail clip)
Frame size	45 mm
Mounting	easy fastening onto 35 mm device rail (DIN)
Degree of protection	IP20
Terminals	M3.5 screws
Terminal capacity	1 — 4 mm ²
Fastening torque of terminals	0.8 Nm
Control coil terminal	M3.5 screws
Control coil terminal capacity	1 — 4 mm ²
Fastening torque of control terminals	0.8 Nm
Mechanical service life	1 000 000 operating cycles
Pollution degree	2
Installation class	III
Weight	0.12 kg (1MU), 0.21 kg (2MU)

Technical Data Ex9CH20

Installation relays

Dimensions

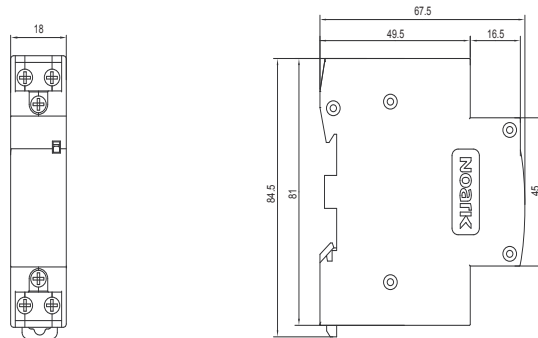

2-contact versions

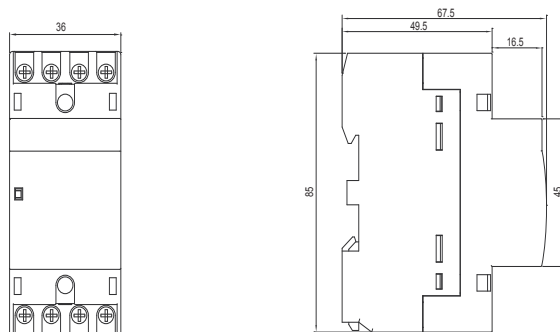

4-contact versions

Mounting position

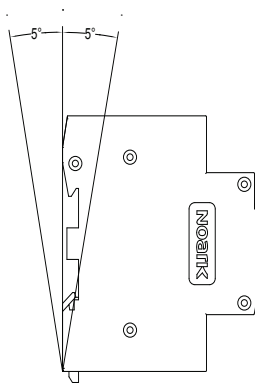

Wiring diagrams

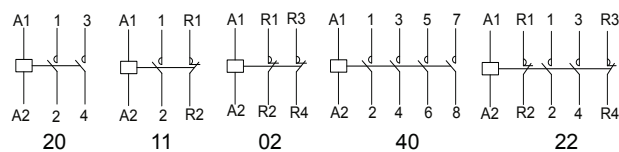

Technical Data Ex9CH

Installation contactors

General parameters

Modular design
Indication window help users to know the status of device
Low operating noise level

Electrical parameters

	ExCH25	ExCH40	ExCH63
Tested according to	IEC / EN 61095		
Rated operational voltage U_e	230/400 V AC		
Control coil voltage U_c	24 V AC / 230 V AC / 240 V AC		
Rated insulation voltage U_i	500 V		
Rated impulse withstand voltage U_{imp}	4 kV		
Rated conventional thermal current I_{th}	25 A	40 A	63 A
Rated current AC-1, AC-7a I_e	25 A	40 A	63 A
Controlled power AC-7a	16 kW	40 kW	40 kW
Electrical service life	100 000 operating cycles		
Max. switching frequency	300 per hour		
Duty	100 %		
Making and breaking conditions AC-7a			
I_c/I_e	1.0		
U_r/U_e	1.05		
$\cos \varphi$	0.8		
Coil power consumption (2P / 4P)	- / 5.31 VA - / 1.56 W	5.10 / 7.13 VA 1.50 / 2.09 W	5.10 / 7.13 VA 1.50 / 2.09 W
Ambient temperature	-5 — +40 °C (+40 — +70 °C derated)		
I_{th} in different ambient temperature			
40°C	25 A	40 A	63 A
50°C	22 A	38 A	57 A
60°C	18 A	36 A	50 A
70°C	16 A	32 A	46 A

Mechanical parameters

	Ex9CH25	Ex9CH40/Ex9CH63
Modules	4-contact: 36 mm (2MU)	2-contact: 36 mm (2MU) 4-contact: 54 mm (3MU)
Device width	18 mm (per module)	
Device height	81 mm (84.5 including rail clip)	85 mm
Frame size	45 mm	
Mounting	easy fastening onto 35 mm device rail (DIN)	
Degree of protection	IP20	
Terminals	M3.5 screws	M5 screws
Terminal capacity	1 — 4 mm ²	2.5 — 16 mm ²
Fastening torque of terminals	0.8 Nm	2 Nm
Control coil terminal	M3.5 screws	
Control coil terminal capacity	1 — 4 mm ²	
Fastening torque of control terminals	0.8 Nm	
Mechanical service life	1 000 000 operating cycles	
Pollution degree	2	
Installation class	III	
Weight	0.21 kg	0.22 kg (2MU), 0.4 kg (3MU)

Ordering data p. 83

Technical Data Ex9CH

Installation contactors

Dimensions

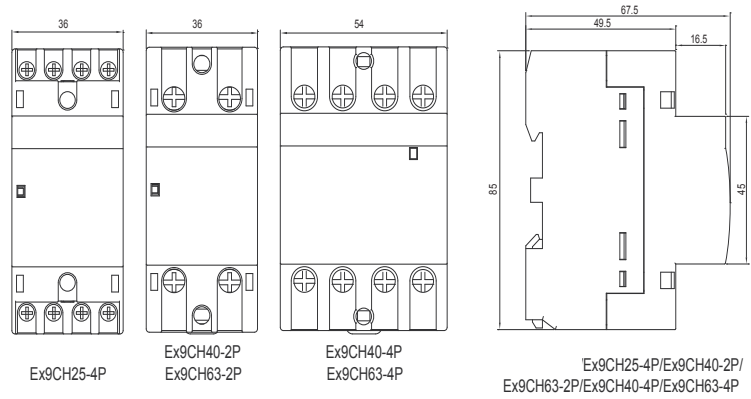

Mounting position

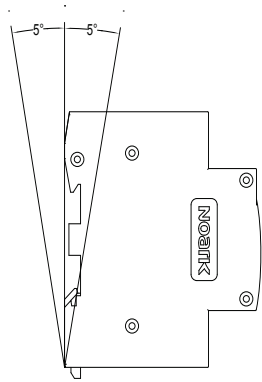

Wiring diagrams

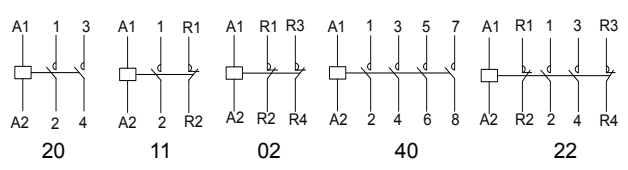

Technical Data Ex9BT

Change-Over Switches

General parameters

Modular change-over switches for switching of auxiliary, control, measuring and other circuits
Also versions in combination with independent signal lamp
Various contact combinations
Suitable for household as well as industrial applications

Electrical parameters

Tested according to	EN 60669-1
Rated op. voltage	230 / 400 V AC
Rated frequency	50 Hz
Rated current I _e	16, 32 A
Number of contacts	1, 2, 3, 4
LED voltage	12-48 V AC/DC 115-230 V AC/DC
LED power loss	290 mW
Rated insulation voltage U _i	690 V
Maximum back-up fuse	125 A gG
Mechanical service life	20 000 operation cycles
Electrical service life	4 000 operation cycles

Mechanical parameters

Device width	18 mm
Device height	83 mm (89 mm including rail clip)
Frame size	45 mm
Mounting	easy fastening onto 35 mm device rail (DIN)
Degree of protection	IP20
LED Color	white
Toggle color	green - NO contacts only red - NC contacts only black - CO only or contact combination
Terminals	lift
Terminal capacity	1 — 10 mm ²
Fastening torque of terminals	2 — 3,5 Nm
Ambient temperature	-30 — +70 °C
Altitude	≤ 2000 m
Relative humidity	≤ 95 %
Resistance to humidity and heat	class 2
Pollution degree	2
Installation class	III
Weight	0.09 kg

Technical Data Ex9BT

Change-Over Switches

Dimensions

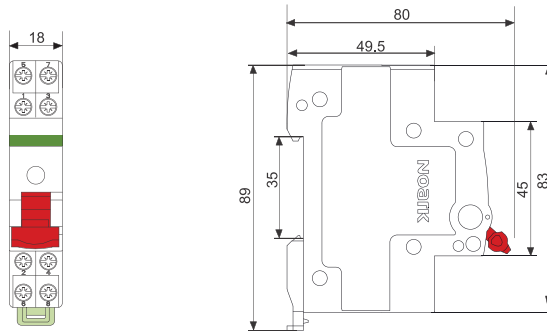

Wiring diagrams

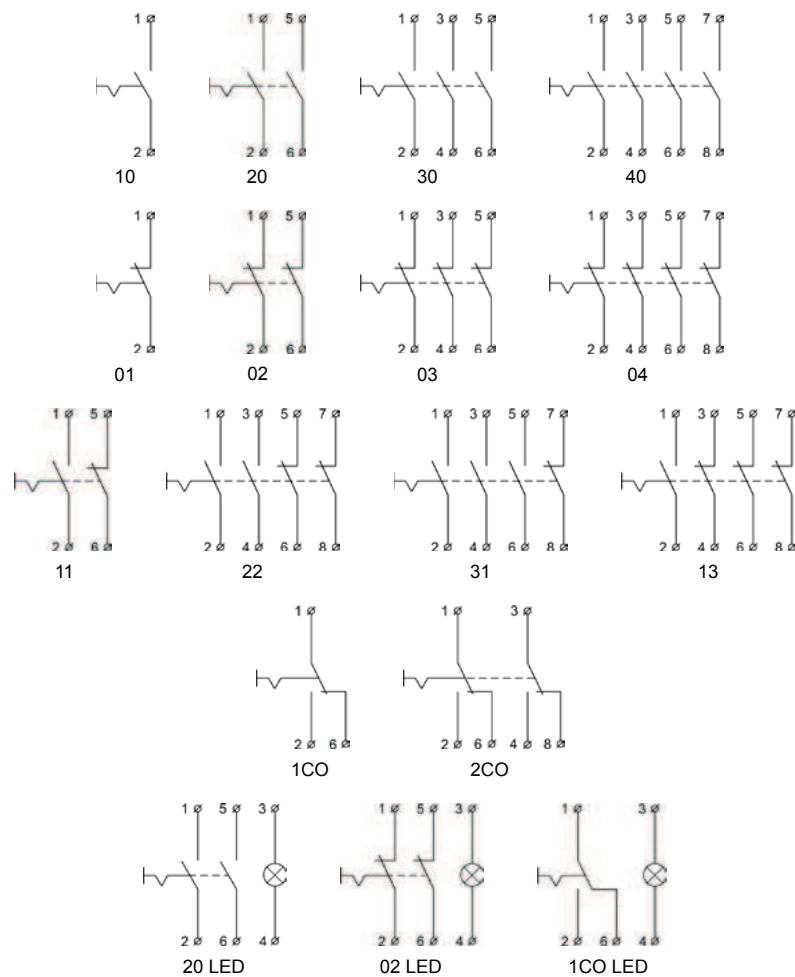

Technical Data Ex9PD

Installation signal lamps

General parameters

Modular design
Suitable e.g. for circuit status indication
Based on LED technology

Electrical parameters

Tested according to	IEC/EN 60947-5-1
Light technology	LED
Number of LEDs	1, 2
LED colours	red, yellow, green, blue, white
Rated operating voltage U_e	6.3 V AC/DC 12 V AC/DC 24 V AC/DC 110 V AC/DC 230 V AC/DC
Rated current I_e	≤ 20 mA / LED
Rated insulation voltage U_i	500 V
Electrical service life	≥ 30 000 working hours
LED lumiance L_v	≥ 60 cd/m ²

Mechanical parameters

Device width	18 mm
Device height	81 mm (84.5 mm including rail clip)
Frame size	45 mm
Mounting	easy fastening onto 35 mm device rail (DIN)
Degree of protection	IP20
Terminals	lift
Terminal capacity	1 — 2.5 mm ²
Fastening torque of terminals	0.8 Nm
Ambient temperature	-5 — +40 °C
Altitude	≤ 2000 m
Relative humidity	≤ 95 %
Resistance to humidity and heat	class 2
Pollution degree	2
Installation class	III
Weight	0.09 kg per pole

Technical Data Ex9PD

Installation signal lamps

Dimensions

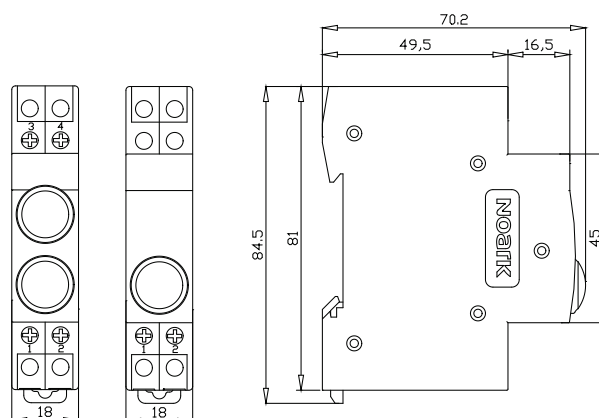

Wiring diagrams

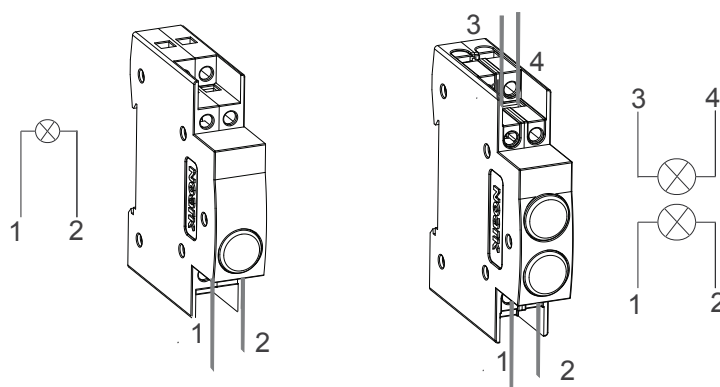

Technical Data Ex9TA

Analogue Time Switches

General parameters

Miniature (1MU width) and standard width (3MU) versions

Quartz or grid synchronous time basis

Electrical parameters

	Ex9TAMS	Ex9TAMQ	Ex9TAQ
Tested according to	EN 60730-1, EN 60730-2-7		
Rated operating voltage U_e	230 V AC	230 V AC 130 V DC	230 V AC 130 V DC
Rated frequency f	50 Hz	50 Hz / DC	50 Hz / DC
Rated current I_e			
AC-1, $\cos \varphi$ 1	16 A		
AC-3, $\cos \varphi$ 0.6	4 A		
Channels	1		
Switch contact	1 NO	1 NO	1 CO
Switching capacity (incandescent lamps)	1000 W	1000 W	1350 W
Rated insulation voltage U_i	2500 V AC	2500 V AC	2500 V AC
Power consumption	1 VA	1 VA	1 VA
Time basis	synchronous	Quartz	Quartz
Accuracy	synchronous to grid	± 2.5 sec./day	± 2.5 sec./day
Power reserve	-	50 hours	150 hours
Charging time	-	100 hours	70 hours
Switching program	daily		
Shortest switching time	30 min.		
Programmable	every 30 min.		
Manual switch	Auto / fix ON		Auto / fix ON / fix OFF

Mechanical parameters

Device width	17.5 mm	17.5 mm	52.5 mm
Device height	90 mm	90 mm	85 mm
Frame size	45 mm		
Mounting	onto 35 mm device rail (DIN)		
Degree of protection	IP20		
Terminals	screw terminals		
Terminal capacity	1 — 4 mm ²	2x 4 mm ²	2x 2.5 mm ²
Fastening torque of terminals	1.2 Nm	1.2 Nm	1.2 Nm
Ambient temperature	-25°C — +55°C	-20°C — +55°C	
Installation class	II		
Sealable	yes		
Weight	0.1 kg	0.11 kg	0.17 kg

Technical Data Ex9TA

Analogue Time Switches

Dimensions

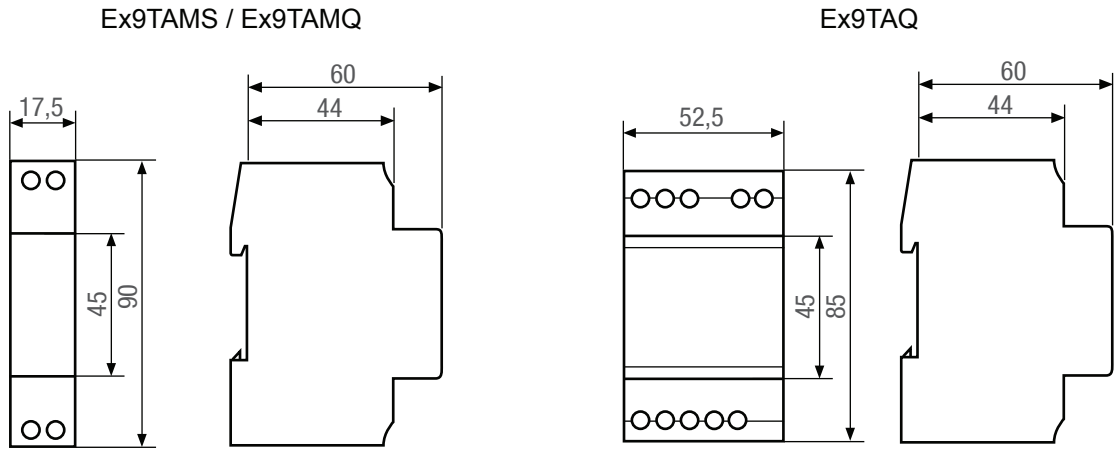

Wiring diagrams

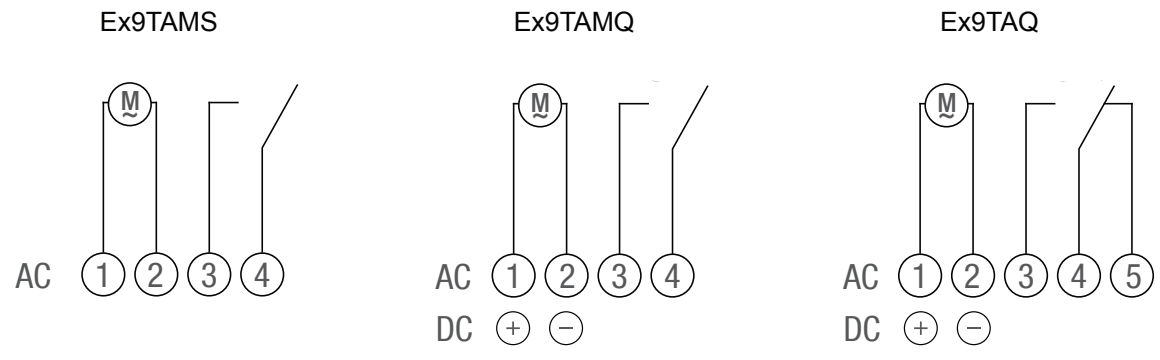

Technical Data Ex9TD

Digital Time Switches

General parameters

Miniature (1MU) or standard width (2MU) versions
Switching state LCD display
Weekly and Holiday switching program
Auto summer/wintertime change

Electrical parameters

	Ex9TDM	Ex9TD	Ex9TDC
Tested according to	EN 60730-1, EN 60730-2-7		
Rated operating voltage U_e	230 V AC	110-230 V AC	110-230 V AC 24 V AC/DC
Rated frequency f	50/60 Hz	50/60 Hz	50/60 Hz
Rated current I_e			
AC-1, $\cos \varphi$ 1	16 A		16 A
AC-3, $\cos \varphi$ 0.6	8 A		10 A
Rated insulation voltage U_i	2500 V AC	2500 V AC	2500 V AC
Power consumption	5 VA	1 VA	1 VA
Rated load AC1 / AC15	-	4000 VA / 750 VA	
Channels	1	1 / 2	1 / 2
Switch contact	1 CO	1CO / 2CO	1CO / 1CO+1NO
Switching capacity AC			
Incandescent lamps	1000 W		2600 W
Fluorescent lamps (uncorrected)	-		1000 VA
Fluorescent lamps (serial corrected)	-		1000 VA
Fluorescent lamps (parallel corrected)	-		730 VA
Fluorescent lamps (duo)	-		1000 VA
Halogen lamps	-		2600 W
Compact fluorescent lamps	-	22x7 W / 18x11 W / 16x15 W / 16x20 W / 14x23 W	
Energy saving lamps	-	37x7 W / 30x11 W / 26x15 W / 26x20 W / 11x23 W	
Sw. capacity DC (24V / 50V / 220V)		800 / 300 / 150 mA	
Min. switching load	-	300 mW	
Shortest switching time	1 min.	1 min.	1 sec.
Programmable	every 1 min.	every 1 min.	every 1 min.
PC programming	-	-	yes
Weekly switching program	ON/OFF	ON/OFF	ON/OFF, Pulse, Cycle
Holiday switching program	ON/OFF	ON/OFF, OFF	ON/OFF, Pulse, Cycle, OFF
Free weekday block	-	yes	yes
Manual switch	ON/OFF	Auto / Override / ON/OFF	Auto / Override / ON/OFF
Astro program	-	-	yes
Auto summer/wintertime change	yes	yes	yes
Switching state display	yes	yes, backlight	yes, backlight
Time basis	Quartz	Quartz	Quartz
Accuracy	± 1 sec./day	± 0.5 sec./day	± 0.3 sec./day
Power reserve (at +20°C)	3 years	3 years	10 years
Replaceable battery type	CR2032	CR2032	CR2450
Memory spaces	50	70	100
Hour counter	-	yes	yes
PIN coded setup	-	yes	yes
Random switching	-	-	yes
External input	-	-	yes

Technical Data Ex9TD

Digital Time Switches

Mechanical parameters

	Ex9TDM	Ex9TD	Ex9TDC
Device width	17.5 mm	35 mm	35 mm
Device height	90 mm	85 mm	85 mm
Frame size	45 mm		
Mounting	onto 35 mm device rail (DIN)		
Degree of protection	IP20		
Terminals	screw terminals		
Terminal capacity	2.5 mm ²	1 — 4 mm ²	1 — 4 mm ²
Fastening torque of terminals	1.2 Nm	1.2 Nm	1.2 Nm
Ambient temperature	-10°C — +55°C	-25°C — +55°C	-25°C — +55°C
Installation class	II		
Weight	0.1 kg	0.17 kg	0.17 kg

Dimensions

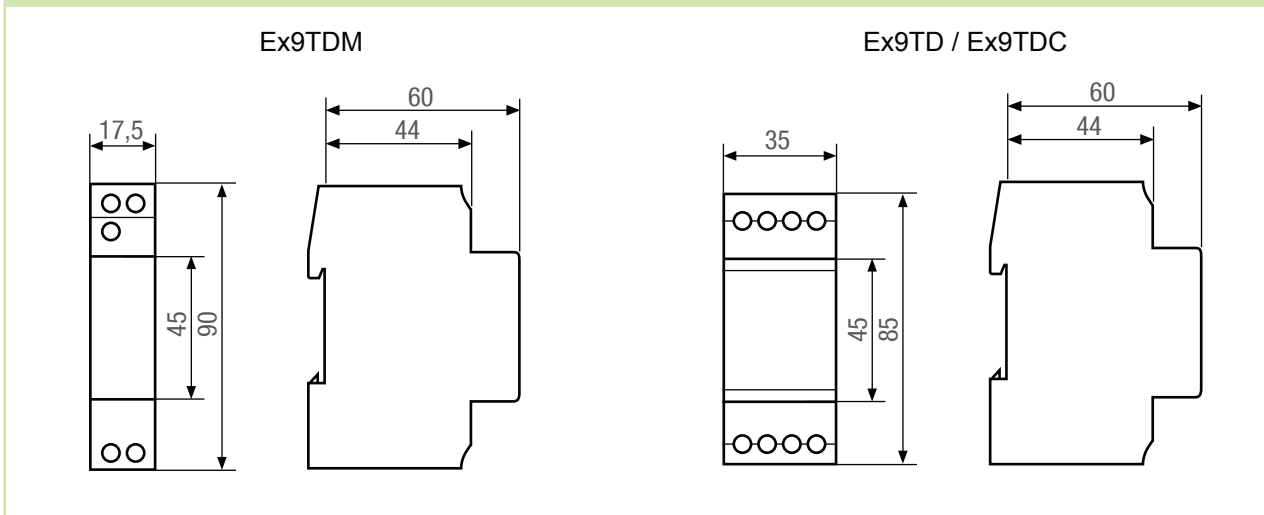

Wiring diagrams

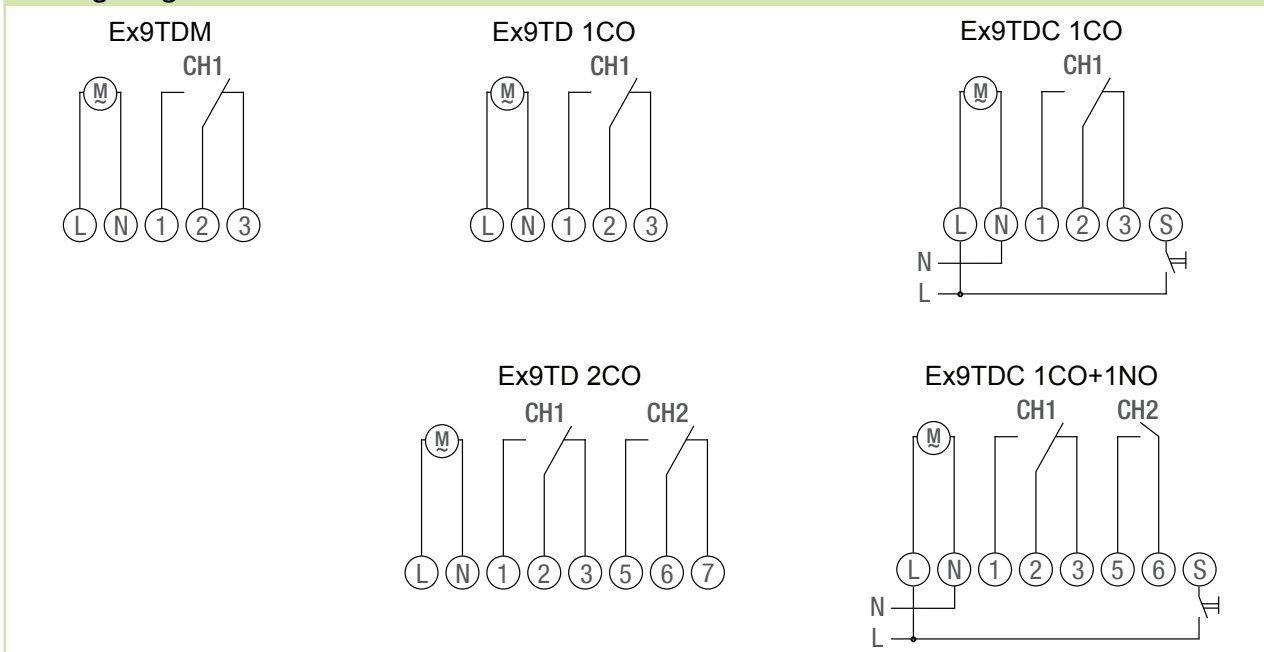

Technical Data Ex9SS

Staircase Switches

General parameters

Time adjustment range from 0.5 to 20 minutes
Manual control switch
Automatic recognition of 3 or 4-line connection

Electrical parameters

Tested according to	EN 60669-1, EN 60669-2-1, EN 60669-2-3
Rated operating voltage U_e	230 V AC
Rated frequency f	50/60 Hz
Rated current I_e	
AC-1, $\cos \varphi$ 1	16 A
AC-3, $\cos \varphi$ 0.6	10 A
Switch contact	1 NO
Adjustment range	0.5 — 20 min
Time extension	no
Reset function	input signal reset adjusted time
Duty of control circuit	100%
Switching capacity	
Incandescent lamps	2300 W
Halogen lamps (low-voltage)	2300 W (1000 W)
Fluorescent lamps (in DUO circuit)	20 x 2 x 58 W
Fluorescent lamps (parallel comp.)	20 x 58 W
Fluorescent lamps (series comp.)	40 x 58 W
EVG	500 VA
KVG	1000 W
CFL (EVG)	10 x 20 W
LEDs	750 W
Rated insulation voltage U_i	2500 V AC
Power consumption	< 1 W
Pilot lights	max. 50 mA
Line voltage connection	below

Mechanical parameters

Device width	17.5 mm
Device height	85 mm
Frame size	45 mm
Mounting	onto 35 mm device rail (DIN)
Degree of protection	IP20
Terminals	screw terminals
Terminal capacity	1 — 4 mm ²
Fastening torque of terminals	0.8 Nm
Ambient temperature	-10°C — +55°C
Installation class	II
Weight	0.1 kg

Technical Data Ex9SS

Staircase Switches

Dimensions

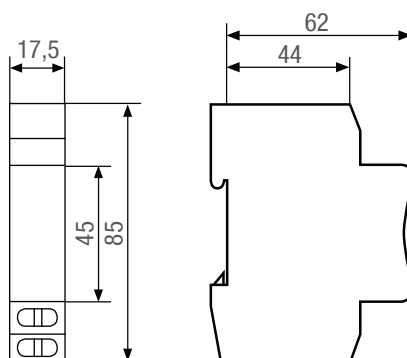

Wiring diagrams

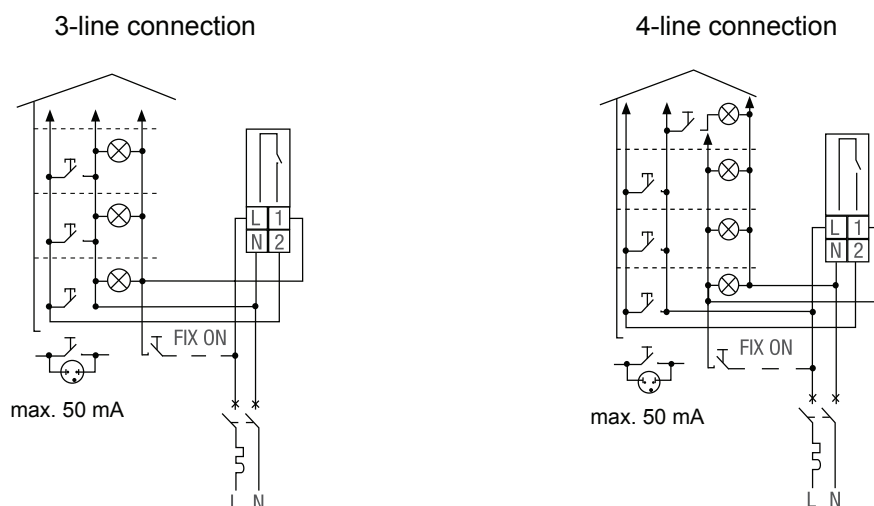

Technical Data Ex9LA

Modular Light Intensity Switches - Analogue

General parameters

For light switching according to actual light intensity
Brightness sensor for surface-mounting in the scope of delivery

Electrical parameters

Tested according to	EN 60669-1, EN 60669-2-1
Rated operating voltage U_e	230 V AC
Rated frequency f	50/60 Hz
Rated current I_e	
AC-1, $\cos \varphi$ 1	16 A
AC-3, $\cos \varphi$ 0.6	8 A
Power consumption	5 VA
Channels	1
Switch contact	NO (normally open)
Switching capacity	
AC (incandescent lamp load)	2000 W
DC (24 V / 60 V / 220 V)	800 mA / 300 mA / 150 mA
Light adjustment range	2 — 500 lx
Hysteresis factor	1.3
Switching delay	fixed, approx. 100 sec.
Switching state display	undelayed
Brightness sensor	external
Maximum length of connecting cables for sensor	100 m

Mechanical parameters

Device width	17.5 mm
Device height	85 mm
Frame size	45 mm
Mounting	onto 35 mm device rail (DIN)
Degree of protection	
device	IP20
brightness sensor	IP65
Installation class	II
Terminals	screw terminals
Terminal capacity	
device	1 — 4 mm ²
brightness sensor	min. 0.75 mm ²
Fastening torque of terminals	1.2 Nm
Ambient temperature	
device	-20°C — +55°C
brightness sensor	-30°C — +70°C
Weight	0.075 kg

Technical Data Ex9LA

Modular Light Intensity Switches - Analogue

Dimensions

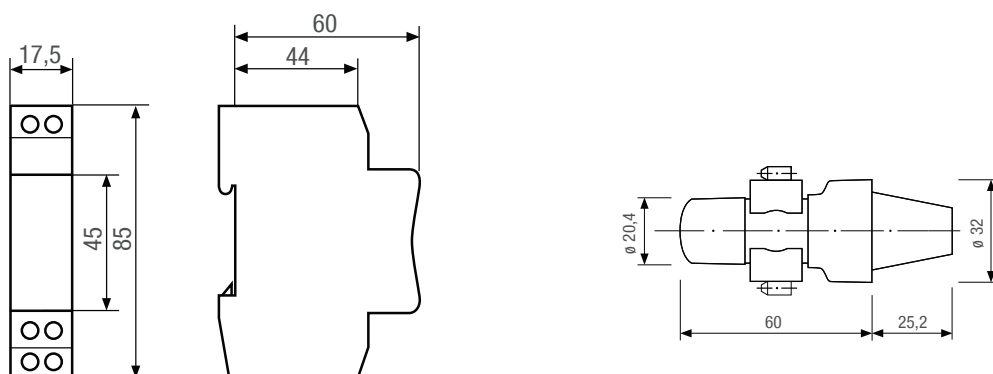

Wiring diagrams

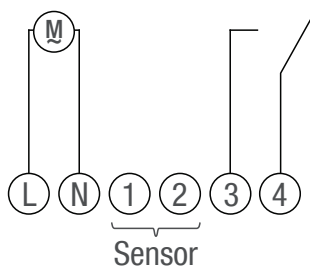

Technical Data Ex9LD

Modular Light Intensity Switches - Digital

General parameters

For switching according to actual day time or light intensity
Modular design
Brightness sensor for surface-mounting in the scope of delivery
Automatic summer/wintertime change
It is possible to connect up to 10 devices with only one brightness sensor

Electrical parameters

Tested according to	EN 60730-1, EN 60730-2-7, EN 60669-2-1
Rated operating voltage U_e	230 V AC
Rated frequency f	50/60 Hz
Rated current I_e	
AC-1, $\cos \varphi$ 1	16 A
AC-3, $\cos \varphi$ 0.6	10 A
Power consumption	5 VA
Channels	2
Switch contacts	CO (change-over)
AC switching capacity	
Incandescent lamp load	2600 W
Halogen lamp	2600 W
Fluorescent lamp (parallel comp.)	1000 W
Fluorescent lamp (series comp.)	1000 W
Max. switching capacity AC1 / AC15	3700 / 750 VA
DC switching capacity (24 V / 60 V / 220 V)	800 mA / 300 mA / 150 mA
Photoelectric switch	
adjustment range	2 — 500 lx
hysteresis factor	1.3
switching delay	0 — 100 sec.
switching state display	undelayed
Time switch	
memory	50 spaces
shortest switching time	1 min.
programmable	every 1 min.
block formation	weekdays
switching state display	yes
summer/winter time	automatic change
manual switch	automatic / fix ON / fix OFF
accuracy	± 1 sec. / day at $+20^\circ\text{C}$
running reserve	ca. 3 years ex works
Brightness sensor	external (in the scope of delivery)
Maximum length of connecting cables for sensor	100 m

Technical Data Ex9LD

Modular Light Intensity Switches - Digital

Mechanical parameters

Device width	52.5 mm
Device height	85 mm
Frame size	45 mm
Mounting	onto 35 mm device rail (DIN)
Degree of protection	
Device	IP20
Brightness sensor	IP65
Installation class	II
Terminals	screw terminals
Terminal capacity	
Device	1 — 4 mm ²
Brightness sensor	min. 0.75 mm ²
Fastening torque of terminals	1.2 Nm
Ambient temperature	
Device	-10°C — +55°C
Brightness sensor	-30°C — +70°C
Weight	0.285 kg

Dimensions

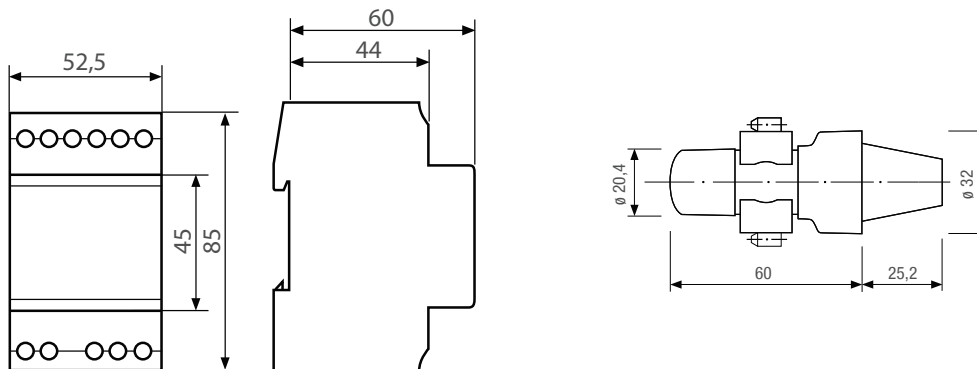

Wiring diagram

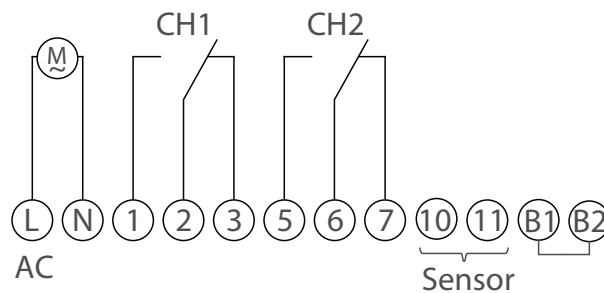

Technical Data Ex9LD

Modular Light Intensity Switches - Digital

Device interconnection

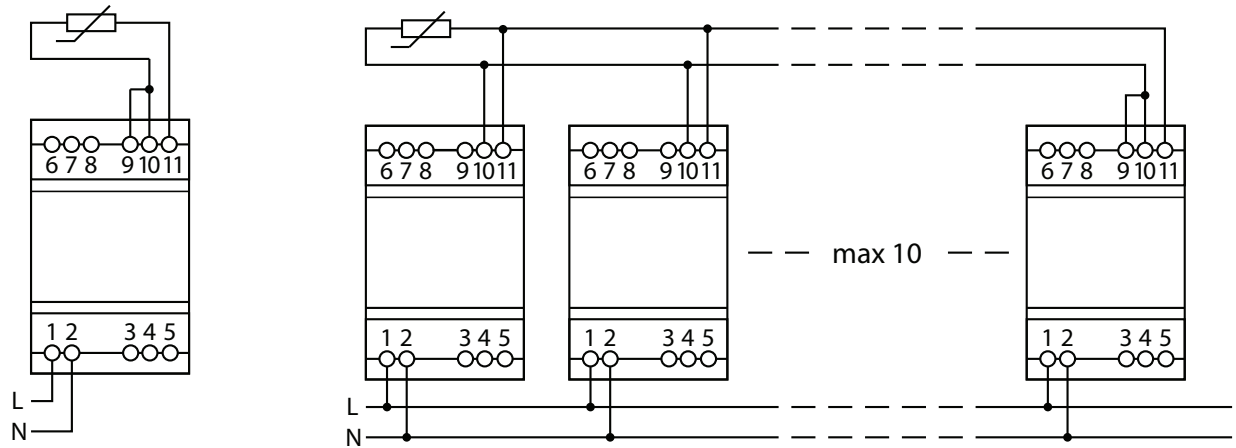

It is possible to connect up to 10 devices with only one brightness sensor.

Index

Type	Ordering data	Technical data	Type	Ordering data	Technical data
AL3111	72	141	Ex9BI 2P	43	121
AX3111	72	141	Ex9BI 3P	43	121
AX3122	72	141	Ex9BI 4P	43	121
AXL31	72	141	Ex9BN	15	104
Ex9B125 1P B	25	107	Ex9BN 1P B	17	104
Ex9B125 1P C	26	107	Ex9BN 1P C	19	104
Ex9B125 1P D	27	107	Ex9BN 1P D	21	104
Ex9B125 1PN B	25	107	Ex9BN 1PN B	17	104
Ex9B125 1PN C	26	107	Ex9BN 1PN C	19	104
Ex9B125 1PN D	27	107	Ex9BN 1PN D	21	104
Ex9B125 2P B	25	107	Ex9BN 2P B	17	104
Ex9B125 2P C	26	107	Ex9BN 2P C	19	104
Ex9B125 2P D	27	107	Ex9BN 2P D	21	104
Ex9B125 3P B	25	107	Ex9BN 3P B	18	104
Ex9B125 3P C	26	107	Ex9BN 3P C	20	104
Ex9B125 3P D	27	107	Ex9BN 3P D	22	104
Ex9B125 3PN B	25	107	Ex9BN 3PN B	18	104
Ex9B125 3PN C	26	107	Ex9BN 3PN C	20	104
Ex9B125 3PN D	27	107	Ex9BN 3PN D	22	104
Ex9B125 4P B	25	107	Ex9BN 4P B	18	104
Ex9B125 4P C	26	107	Ex9BN 4P C	20	104
Ex9B125 4P D	27	107	Ex9BN 4P D	22	104
Ex9BD 1P C	35	114	Ex9BT2	86	163
Ex9BD 1P K	36	114	Ex9BT2 LED	86	163
Ex9BD 2P C	35	114	Ex9CBL-H	53	132
Ex9BD 2P K	36	114	Ex9CBL-N	59	135
Ex9BH	7	101	Ex9CL-100	45	126
Ex9BH 1P B	9	101	Ex9CL-100 2P	48	126
Ex9BH 1P C	11	101	Ex9CL-100 4P	48	126
Ex9BH 1P D	13	101	Ex9CL-H	45	123
Ex9BH 1PN B	9	101	Ex9CL-H 2P	46	123
Ex9BH 1PN C	11	101	Ex9CL-H 4P	46	123
Ex9BH 1PN D	13	101	Ex9CL-N	51	129
Ex9BH 2P B	9	101	Ex9CL-N 2P	52	129
Ex9BH 2P C	11	101	Ex9CL-N 4P	52	129
Ex9BH 2P D	13	101	Ex9CH20	81	159
Ex9BH 3P B	10	101	Ex9CH25	84	161
Ex9BH 3P C	12	101	Ex9CH40	84	161
Ex9BH 3P D	14	101	Ex9CH63	84	161
Ex9BH 3PN B	10	101	Ex9I125	37	117
Ex9BH 3PN C	12	101	Ex9I125 1P	38	117
Ex9BH 3PN D	14	101	Ex9I125 2P	38	117
Ex9BH 4P B	10	101	Ex9I125 3P	38	117
Ex9BH 4P C	12	101	Ex9I125 4P	38	117
Ex9BH 4P D	14	101	Ex9I40	39	119
Ex9BI 1P	43	121	Ex9I40 1P	40	119

© NOARK Electric Europe s.r.o. | C000021 Cat InstDevices EU-EN 2013

NOARK Electric Europe s.r.o.

Sezemicka 2757/2, 193 00 Prague 9, Czech Republic

Phone: +420 226 203 120

E-mail: Europe@noark-electric.com

www.noark-electric.eu

NOARK
New opportunity for you